



COUNTY OF SANTA BARBARA PLANNING AND DEVELOPMENT

MEMORANDUM

TO: Board of Supervisors

FROM: Lisa Plowman, Director, Planning & Development Department *Lisa Plowman*

DATE: October 27, 2022

HEARING DATE: November 1, 2022

RE: Appendices (Appendix 1 & Appendix 2) to Exhibit A Statement of Work for the Agreement for the Services for Independent Contractor with Geosyntec Consultants, Inc.

Summary

The following appendices are to be included as Appendix 1 and Appendix 2 to Exhibit A – Statement of Work to Attachment A – Agreement for Services of Independent Contractor between the County of Santa Barbara and Geosyntec Consultants, Inc. for the Board of Supervisors Administrative Agenda Item A-23, File No. 22-00972 for the Hearing of November 1, 2022.

Attachments:

1. Appendix 1 - Geosyntec Consultants Inc. Cannabis Odor Control Systems and Odor Abatement Plan Monitoring Reporting and Compliance Assurance Technical Proposal dated April 21, 2022
2. Appendix 2 - Geosyntec Consultants Inc. Cannabis Odor Control Systems and Odor Abatement Plan Monitoring Reporting and Compliance Assurance Cost Proposal dated April 21, 2022.

Appendix 1

**Geosyntec Consultants Inc. Cannabis Odor Control Systems and Odor
Abatement Plan Monitoring Reporting and Compliance Assurance Technical
Proposal dated April 21, 2022**



Proposal to the County of Santa Barbara
Planning and Development Department

FOR

**CANNABIS ODOR CONTROL SYSTEMS AND ODOR
ABATEMENT PLAN MONITORING, REPORTING,
AND COMPLIANCE ASSURANCE
CONSULTANT SERVICES**

April 21, 2022

ATTN: Elise Dale
County of Santa Barbara
Planning and Development Department
123 East Anapamu Street
Santa Barbara, CA 93101
daleel@countyofsb.org
(805) 568-2000

Dan Dowdy
Geosyntec Consultants, Inc.
Santa Barbara
924 Anacapa St Ste 4A,
Santa Barbara, CA 93101
dan.dowdy@geosyntec.com
(805) 979-9169

April 21, 2022

County of Santa Barbara, Planning and Development Department
123 East Anapamu Street
Santa Barbara, CA 93101
(805) 568-2000
daleel@countyofsb.org

Subject: Request for Proposals - Cannabis Odor Control Systems and Odor Abatement Plan Monitoring, Reporting, and Compliance Assurance Consultant Services

Dear Ms. Dale:

Geosyntec Consultants, Inc. (Geosyntec) appreciates the opportunity to submit this proposal to the County of Santa Barbara (County) Planning and Development Department (Department) to provide cannabis odor control systems and odor abatement plan monitoring, reporting, and compliance assurance consulting services. This proposal was prepared in accordance with the Request for Proposal (RFP) issued on March 10, 2022.

Our team of local, qualified, odor and air modeling, monitoring and compliance reporting specialists look forward to the opportunity to serve the Department and our local community needs related to Cannabis Odor Compliance Assurance needs. *Geosyntec affirms that they do not currently, nor have they in the past, worked directly for or represented any Cannabis operator in the County of Santa Barbara.*

This proposal is signed by Maygan Cline, the individual authorized to commit Geosyntec. Geosyntec respectfully notes that an example contract was provided for Independent Contractors however, we assume a Professional Services contract may be the likely contract mechanism for the proposed scope. Given that Geosyntec currently provides Professional Services to other County departments, we are prepared to accept the terms and execute a Professional Services contract for the described scope of services.

This proposal and its contents will remain effective for a period of 60 days from the proposal due date of April 21, 2022.

Sincerely,

Geosyntec Consultants, Inc.

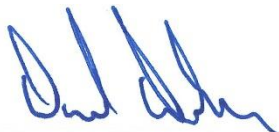

Dan Dowdy, PE
Project Manager
dan.dowdy@geosyntec.com
(805) 979-9169



Maygan Cline, PG, QSD/QSP
Project Director
mcline@geosyntec.com
(805) 979-9130

Table of Contents

a. Introduction	1
Project Understanding	1
Prime Contractor	2
Geosyntec Consultants, Inc.	2
b. Qualifications.....	3
Firm Capabilities.....	3
Brief History.....	5
Organizational Structure.....	5
Relevant Experience.....	6
c. Staff.....	13
Organizational Chart.....	13
Key Staff Relevant Experience.....	14
Estimated Staffing Hours	17
d. Study Methodology	18
Approach.....	18
Optional Tasks for County Cannabis Odor Compliance.....	24
e. References	26
f. Attachments	27

a. Introduction

Project Understanding

Geosyntec Consultants, Inc. (Geosyntec) prepared this proposal in response to the County of Santa Barbara (County) Planning & Development Department (Department) request for proposals for Professional Consultant Services. The services to be provided include planned and on-call professional services for Cannabis Operations Odor Abatement Plan component inspection, testing, monitoring, reporting, preparation of recommended corrective actions in cases of non-compliance.

Geosyntec has a long history of providing environmental services within Santa Barbara County and has partnered with the County on numerous local projects over the years. Our Santa Barbara office is located at 924 Anacapa Street, mere blocks away from the main County offices. Our local office presence includes more than 40 scientists and engineers including technical experts who routinely lead chemical investigations projects, engineers who are versed at inspecting and testing air and vapor systems for compliance, and staff who are at the ready to mobilize to project sites to support the Departments' cannabis odor compliance and/or odor nuisance needs. Geosyntec is committed to partnering with Department staff to provide an effective and efficient inspection and monitoring program that supports Department oversight needs, cannabis operator compliance objectives, and public stakeholder concerns for existing and future cannabis projects.



GEOSYNTEC HAS A LONG
HISTORY OF PROVIDING
EXCEPTIONAL CONSULTING
SERVICES TO THE COUNTY OF
SANTA BARBARA

We understand that there is the potential for 70 different cannabis projects within the county and close coordination and collaboration with Department staff will be needed to successfully implement the Department's cannabis odor compliance program. Currently, there are different types of cannabis operations in the county that may emit odors and we understand that each of these operations need to be considered and evaluated on a site-specific basis.

Initial site inspections will confirm that the cannabis operation is complying with their approved Odor Abatement Plan(s) (OAP). Those initial site visits will be conducted by experienced local engineering staff either during installation of the approved OAP system, or after it's installation but prior to system startup and use. Those site inspections will confirm that the OAP system equipment, componentry, odor-neutralizers, misters, etc., are installed in accordance with the approved OAP. If the operation is not compliant with the approved OAP, Geosyntec will collect photos and detailed field notes to support preparation of recommended compliance actions. The compliance status will be communicated to the Department, and upon receipt of Department concurrence with Geosyntec's recommended compliance actions, those actions will be communicated to the cannabis operator to support their path to compliance. Additional site visits will be conducted to confirm the recommended compliance actions are implemented appropriately until the operator is determined compliant with their approved OAP. Once compliance is established, routine quarterly OAP compliance inspections will be conducted to confirm the systems continue compliant operations. Similar to initial site inspections, if non-compliance items are observed during the quarterly site inspections, detailed notes and photos will be collected to support development of recommended compliance actions. The recommended compliance actions will be communicated to the Department, and upon receipt of Department concurrence, will be communicated to the operator.

While we understand that every cannabis operator and site is different, there are common cannabis cultivation activities that may produce odors, including, outdoor and indoor cultivation processes, harvesting and drying mature plants, bucking and processing dried plants, and harvest waste storage and export. Although these activities have the potential to produce odors, we understand the most significant odors are primarily produced during the flowering stage of cultivation. Most of the pungent aromas from cannabis are from a class of chemicals called terpenes, which are among the most common compounds produced by flowering plants. As a result, a key investigative tool for evaluating odor sources, odor abatement plan compliance, and responding to odor nuisance complaints, is the assessment of terpene chemical concentrations in air. An additional important consideration is odor migration patterns with changing meteorological conditions. Studies have indicated that odors can lessen on cooler overcast days and can increase as temperature increases. Odors can also increase at night when calmer wind conditions are present. As a result, meteorological conditions along with odor monitoring must be considered. VaporSafe will be providing us with both laboratory and field-based analysis of terpenes for the project. The field monitoring approach provides near real time information that can be used to pinpoint odor emission sources and odor disposition.

In addition to the use of VaporSafe as a laboratory for more detailed analysis during investigating odor complaints, real-time field monitoring will be conducted using the St Croix Sensory Nasal Ranger® Olfactometer. The Nasal Ranger® will be used by trained professionals to evaluate the effectiveness of odor control technologies being employed at the various facilities across the County during routine and quarterly inspections, and in response to odor nuisance complaints.

We will work closely with Department staff to efficiently share the results from inspections, including compliance versus non-compliance status, and engineering recommendations for modifications to odor control equipment if needed, to support operators in achieving compliance. Additionally, should the need arise, the local Geosyntec team can prepare presentation materials and visuals to support technical and non-technical communication updates to the County Board of Supervisors (BOS), to public stakeholders, or Cannabis operators and interest groups, as appropriate.

Prime Contractor



Geosyntec Consultants, Inc.
924 Anacapa St Ste 4A,
Santa Barbara, CA 93101
<https://www.geosyntec.com/>

engineers | scientists | innovators

b. Qualifications

Firm Capabilities

Geosyntec is a specialized consulting and engineering firm working with public- and private-sector clients to address their new ventures and most complex problems involving the environment, natural resources, public and stakeholders, and civil infrastructure. Geosyntec has a staff of over 1,700 engineers, scientists, and other technical and project staff, with over 400 professionals located in over 14 offices throughout California. Most relevant, Geosyntec has maintained a local Santa Barbara office since 2000 that has supported many projects for Santa Barbara County since that time. Our local office is located only blocks away from County offices and houses over 40 scientists and engineers including staff who are experts in conducting chemical investigation projects and evaluating remedial systems to mitigate chemical impacts. Geosyntec's local presence and diversity of capabilities will allow us to be responsive and efficient in addressing the County's needs on this project.

Geosyntec is known for its innovative work in a wide range of projects and for a variety of target regulatory compounds including emerging contaminants, as listed below:

- emissions and air modeling;
- ambient instantaneous and near-real-time air sampling and analytical testing;
- odor nuisance assessment, testing, risk assessment, mitigation and compliance;
- human health and ecological risk assessments;
- expert witness testimony on air, odor and human health risk topics;
- community and stakeholder outreach and public engagement during meetings; and
- treatment system design, permitting, construction, testing, optimization and inspection for air, vapor and water media,

These unique skills and expertise will allow Geosyntec to provide high-value support to the Department to address their complex cannabis odor control systems, odor abatement plan monitoring, reporting, and compliance assurance needs.

Our local Santa Barbara staff have worked on chemical investigation, odor monitoring, and evaluation of odor control systems at some of the highest profile sites in southern California. Brief descriptions of those high-profile projects are provided below.

- **SoCalGas Aliso Canyon gas leak in Porter Ranch.** Geosyntec staff developed the facility and community air monitoring plan and directed a team of scientists in coordinating data collection and analysis for use in evaluating ambient air quality on a daily basis. A key component of the project was weekly briefings with the Los Angeles County Health Department, local school district, South Coast Air Quality Management District and California Air Resources Board with respect to the air data findings.
- **Ascon Landfill in Orange County.** Geosyntec conducted an odor assessment to facilitate design of an odor control system for excavation of odorous soils under a sprung structure and for the full-scale remedy. Odor and volatile organic compound (VOC) control was monitored daily at key points of the system. In addition, Geosyntec is directing a significant ongoing perimeter and community ambient air monitoring program for the landfill and bordering residential neighborhood, high school, and public park. Assessments have been made on the efficacy of odor control agents such as ecosorb plant-based compounds and CupriDyne as an iodine-based odor neutralizer.

- **Frank R. Bowerman Landfill.** Geosyntec assisted Orange County in an emergency response when the Silverado fire impacted the landfill gas control systems. We developed an air monitoring program to assess potential health effects within the community as the landfill systems were repaired and supported the county in weekly and monthly community meetings.
- **County of Santa Barbara Resource Recovery and Waste Management Division (RRWMD).** Geosyntec has supported RRWMD since 2018 with their groundwater and stormwater compliance monitoring, sampling, and reporting efforts for the Class III Tajiguas Landfill and four other closed landfills. Services support RRWMD compliance with their Waste Discharge Requirements and Monitoring & Reporting Program requirements as directed by the Central Coast Regional Water Quality Control Board. Geosyntec also provides Landfill Gas (LFG) system inspection, evaluation, optimization, testing and reporting services to support RRWMD objectives.
- **Local downtown Santa Barbara site.** Geosyntec designed a soil vapor extraction and treatment system to remove and treat volatile organic compounds (VOCs) from soil pore space at the site. Geosyntec also obtained permits for the system from the Santa Barbara County Air Pollution Control District. Geosyntec is currently responsible for continued system operation, maintenance, monitoring, and compliance air sampling to confirm the treated air is free of VOCs and protective of human health for nearby residents and schools.

In addition to the skills and experience highlighted above, Geosyntec is versed in the following areas:

- soil vapor extraction (SVE) system design, permitting, construction, and operations and maintenance (O&M);
- landfill gas (LFG) system design, permitting, O&M and optimization;
- water and wastewater engineering applications, including feasibility studies, treatability testing, design of water and wastewater treatment systems for target regulated and/or emerging contaminants;
- designing water storage tanks, designing distribution systems, including pump stations, pipelines, and interconnections;
- hydraulic modeling; designing and implementation of complex stormwater management systems;
- permitting support; and
- regulatory compliance support.

Given these skills, Geosyntec can answer a range of potential questions or needs that may develop related to cannabis operation wastewater or stormwater, should they be required in the future.

Geosyntec maintains a multidisciplinary team of highly trained civil, mechanical, and process engineers who develop new technologies to address evolving issues and environmental impacts to air, soil, groundwater, surface water, wastewater, and/or stormwater resources. Geosyntec has made advances in the development of destructive technologies to treat Perfluorooctane Sulfonate (PFAS) and Perfluorooctanoic Acid (PFOA), 1,4-dioxane, hexavalent chromium, and other emerging contaminants. Additionally, SiREM, a Geosyntec company, is renowned for their research and development capabilities for innovative analytical testing methods for new and emerging contaminants in a variety of media. An example is the recently deployed PFASive™ sampler, used to measure dissolved PFAS in the aquatic environment and support risk assessment, toxicity identification, remediation design and/or monitoring. SiREM's experience developing innovative technologies could potentially support Department in evaluating the feasibility of developing cannabis odor fingerprinting analytical methodology, if warranted. We have also included our vendors, VaporSafe and St. Croix Sensory, to provide odor panel and chemistry analytical services for odor monitoring. VaporSafe is a leading provider of real-time monitoring of terpenes

in the environment and has significant experience in providing these services for cannabis operations. St Croix Sensory is a leader in the field for odor monitoring and testing and is the developer of the popular field olfactometer, Nasal Ranger® Olfactometer, often used in real-time monitoring of odors. Geosyntec has partnered with St Croix on several projects, most notably the Ascon Landfill Site where a significant amount of investigative work has been done to identify odorous materials requiring mitigation.

To effectively serve the Department's needs, Geosyntec is committed to listening to and understanding your needs, objectives, and concerns to identify, design, and offer the most cost-effective and compliant solutions available. Our practical solutions are based on a portfolio of projects conducted for a diversity of municipal clients. Specifically, Geosyntec has a long history serving the County's Public Works Department, RRWMD, and has a long history of supporting the County Counsel's needs. For RRWMD, Geosyntec supports their on-going groundwater and stormwater compliance monitoring and reporting programs at their open and closed landfills sites. Geosyntec also provides strategic support with regulatory engagement, remedial system design, inspection, testing and sampling, reporting, and regulatory engagement for system shutdown upon achievement of system remediation objectives, in support of the RRWMD goals.

Brief History

Geosyntec was founded in 1983 and since then we have grown based on the application of sustainability principles to projects involving engineering and design for environmental, water resources, civil infrastructure, environmental contamination studies and remediation; natural resources assessment and restoration; and compliance management for air emissions, wastewater discharges, and waste disposal. We are known for our technology leadership, broad experience, and exceptional client service.

As noted above, our local office employs over 40 staff. Our local staff include experts in odor evaluation and control. These staff have led significant investigations, including evaluation of odor control systems, at several significant project sites including the Ascon Landfill adjacent to a high school, park and community in Orange County and the Aliso Canyon gas leak in Porter Ranch (San Fernando Valley).

Our public sector clients include departments and agencies of municipal, state/provincial, regional, and national governments. Our private sector clients come from a variety of industries including oil and gas, chemical, aerospace, pharmaceutical, diversified manufacturing, advanced technology, power and utility, and environmental management. Our private sector clients also include regional and national developers, large commercial property owners, and law firms.

Organizational Structure

The Geosyntec Santa Barbara Branch will manage and lead the Cannabis Odor Compliance Assurance needs for the County and will include key technical experts in the fields of air monitoring and modeling, odor mitigation and monitoring, risk assessment, systems engineering and public engagement.

Top Management

Maygan Cline, Principal
Mark Grivetti, Senior Principal

Company Type

C Corporation

Federal Tax ID No.

59-2355134

Relevant Experience

Landfill Site – Odor Assessment, Risk Assessment, Remedy Design Project | Orange County, CA



Client: Confidential

Services Provided:

- Site Assessment
- Risk Assessment
- Odor Assessment
- Engineering Design
- Geotechnical Engineering
- Permitting
- Regulatory Agency Negotiations
- Planning
- Community Relations Support

Project Description

The site is a 38-acre landfill located in Orange County, California that operated from 1938 through 1984 receiving oil exploration and production wastes, by-products from refining processes, impacted soil, and general construction debris. Geosyntec has provided services to the Responsible Party (RP) Group for 20 years and has developed trusted working relationships with the RP Group and the Site Coordinator. Overall site activities were conducted under regulatory oversight of the California Department of Toxic Substances Control (DTSC) in compliance with an Administrative Clean-Up Order (Order). Throughout the project lifecycle, Geosyntec provided a multitude of planning and assessment services including preliminary environmental assessments (PEAs), Phase II assessments, supplemental on- and off-site soil, groundwater, risk assessment and air quality/odor assessments including workplans for feasibility evaluations, emergency actions, surveys, and remedial planning.

A risk assessment was conducted to quantify potential human health risks and noncancer hazards from volatile chemical emissions and ambient air monitoring was conducted to evaluate the risk assessment results. Ongoing ambient air monitoring is being conducted at the property perimeter and within the community to provide measurement data for air quality analysis and risk communication. Geosyntec developed the air monitoring plan and oversaw the data analysis and reporting to the local air quality district and state agency as well as provided risk communication support to the project.

As part of the remedial design and implementation, Geosyntec provided project management and general oversight during the execution of the assessment and remedy. Geosyntec also provided local agency and air district permitting support and agency negotiations, with the final remedy incorporating an engineered RCRA-equivalent cap with a gas collection and treatment system, gas monitoring perimeter probes, perimeter access road, fencing, and landscaping. A separate onsite pit containing noxious chemical manufacturing waste products was designed to be excavated and disposed off-site. Given the nature of the material (odorous, VOC emissions), the excavation was performed beneath an enclosed structure under negative pressure with an air treatment system. Geosyntec was the lead engineer on the design and implementation of the remediation, providing risk assessment and air modeling services to obtain the air permit from the local air district and assisting in evaluating the effectiveness of various odor control technologies and compounds such as Ecosorb and CupriDyne.

Remedial planning required an odor assessment to assess potential odor emissions during remediation. The investigation included in-situ and ex-situ soil vapor sampling for chemical and odor analysis. Research was conducted to determine potential odor causing chemicals in the waste and the appropriate analytical methods for analysis. In addition to odor causing potential, data were reviewed with respect to potential toxic effects of measured concentrations. The findings were interpreted using a three-dimensional data visualization model. Correlations between measured and modeled odor parameters and chemical composition of the soil vapor sampling were used to assess potential emissions to outdoor air during excavation activities and to identify areas of higher odor causing potential to aid in remedial action planning.

Site Characterization and Remediation Services Meter-Run Header Honor Rancho Natural Gas Storage Field | Santa Clarita, California



Client: Southern California Gas Company

Services Provided:

- Soil and Soil Gas Characterization
- Delineation of Impacts
- HHS and Nuisance Odor Threshold Development
- Air-Dispersion Modeling
- Remedial Feasibility Evaluations
- Targeted Soil Remediation

Project Description

Following the identification of a historical odorant release (tetrahydrothiophene and tert-butyl-mercaptan) in 2019, Geosyntec supported SoCalGas through an extensive investigation to evaluate the vertical/lateral limits of odorant impacts in soil and soil vapor in support of a natural gas header replacement project. Project work involved developing compound-specific Human Health Screening Levels (HHSs) and nuisance odor thresholds and site-specific air-dispersion modeling to delineate the areas where (during excavation) there may be elevated risk for construction workers, and where soil disturbance may generate nuisance odors capable of migrating offsite to sensitive receptors. Following these activities, an enclosure and negative-pressure air system was installed, and targeted soil remediation was performed to excavate impacted soils that presented a risk for offsite odor migration. Due to the proximity to active high-pressure gas lines, excavation methods included hydro-excitation, manual excavation, and mechanical excavation in areas outside off the primary area of impacts. Due to the elevated VOC concentrations, staff were required to don Level C PPE, and continuously monitor air conditions for hazardous atmospheres, while implementing SCAQMD Rule 1166 monitoring for excavation of VOC-contaminated soils.

Geosyntec's Scope of Services

- Characterization of surface and near surface soil and soil vapor impacts, lateral and vertical delineation of subsurface odorant impacts.
- Prepare compound-specific screening levels to support identification of areas where human health and/or nuisance odor risks could be generated.
- Work Plan preparation to support targeted soil remediation
- Implementation of targeted soil remediation to support site compliance and protect facility workers
- Perform SCAQMD Rule 1166 monitoring and reporting.

Notable Accomplishments

- Safely implementing physically demanding work within an enclosed area with high VOCs.
- Rigorous health and safety evaluations, and soil/soil gas characterization activities.
- Expedited development and implementation of project work plans and mobilization of large equipment.
- Successful implementation of dynamic scope of work; adaptively modifying to changing field conditions.
- Coordination with client representatives (and their contractors) to successfully manage and implement a complex project where stakeholder priorities varied significantly.

Air Monitoring Services, Multiple Facilities | Southern California



Client: Southern California Gas Company

Services Provided:

- Developing air monitoring programs
- Facility and community air monitoring
- Air district coordination
- Subject matter expert services
- Forensic studies

Project Description

Project Summary

Since 2015 Geosyntec has supported SoCalGas by providing comprehensive air monitoring services at multiple facilities throughout their expansive southern California service area.

Air Quality Services Provided by Geosyntec

- Characterizing air quality at multiple gas storage fields, compressor stations and other natural gas transmission/distribution facilities.
- Performing background air studies to establish baseline air quality conditions.
- Implementing community air monitoring studies to evaluate potential impacts from nearby facilities.
- Performing long-term monitoring to evaluate constituents of concern in ambient air.
- Developing fence line monitoring systems.
- Developing and maintaining databases used to evaluate detected constituents, trends, and response actions, as needed.
- Evaluating sources of air quality impacts.
- Evaluating, developing, and implementing mitigation alternatives to address air quality issues.
- Evaluating and implementing odor mitigation alternatives.
- Performing forensic studies involving isotopic analyses of samples to assist in the identification of constituents in ambient air and subsurface soil gas samples.
- Providing emergency response services involving rapid mobilization of contractors, equipment, supplies, and trained personnel to provide monitoring and mitigation services.
- Coordinating collection and laboratory analyses of hundreds of air and subsurface soil gas samples.
- Providing public information assistance and participating in public meetings

Notable Accomplishments

- Close coordination with SoCalGas, regulatory agencies, and multiple contractors to successfully manage and implement multiple complex projects where stakeholder priorities varied significantly.
- Successful implementation of multiple high-profile air quality projects under challenging conditions.
- Expedited development and implementation of project work plans and mobilization of large equipment.

Investigation of Sources of Hydrogen Sulfide, Ammonia, Dissolved Gases and Odors at the Discharge of a Leachate Treatment System



Client: Confidential

Services Provided:

- Landfill leachate sampling
- Leachate dissolved gas/odor characterization (H₂S, NH₃, VOCs)
- Leachate degassing optimization
- Off-gas treatment for the removal of odor using granular activated carbon
- Evaluation of sewer siphon for the formation of sewer gases
- Regulatory negotiations

Project Description

Geosyntec's project objectives for this client's project included: determining the best technology for biogas sulfur removal for biogas use in existing boilers; developing alternatives for non-process wastewater reuse in cooling towers using ultrafiltration and reverse osmosis, and developing a concept design for infrastructure upgrades including relocation of electrical room, new pipe racks and pump station replacements.

Geosyntec was retained by a confidential client to optimize the operation of a closed municipal landfill leachate treatment system. One of the main objectives of this project was to identify the source(s) of headspace gases, including methane and H₂S, in a municipal sewer system located adjacent to a closed landfill. Potential sources of sewer gases evaluated for this study included landfill gas migration, off-gassing of dissolved gases in landfill leachate discharged to the municipal sewer system, and sewer gas formed in the sewer and an associated siphon located downstream of the leachate discharge to the main sewer. In addition, Geosyntec evaluated the impact of sewer siphon design considerations to minimize sewer gas formation and siphon maintenance. To evaluate off-gassing of dissolved gases from landfill leachate, samples were collected prior to discharge to the sewer and dissolved gas concentrations were measured. The sewer gas has been monitored daily for the last three years using hand-held monitors. A detailed review of the sewer siphon design was also conducted and contrasted against the standards of practice.

- Geosyntec demonstrated that there is no landfill gas migration between the landfill and the sewer.
- We demonstrated that the landfill leachate is effectively degassed under vacuum and is not the source of the gases in the headspace of the adjacent sewer.
- Flow velocities through the siphon were estimated based on flow data and it was found that during dry weather the flow velocities were less than 0.6 fps, which is significantly lower than the recommended design velocities of greater than 2fps for self-cleaning.
- The results indicated that the concentrations of methane and H₂S at the sewer manholes decreased drastically following heavy precipitation, suggesting that sewer siphon flow velocities increased due to wet weather allowing flushing velocities to be achieved that remove sewer pipe sediment and bioslime, thus eliminating the formation of sewer gases.
- Geosyntec demonstrated the production of sewer gas, including methane and H₂S in the sewer system at the upleg and the downleg of the siphon.
- Demonstrated that there is a significant backdraft at the upleg of the siphon that results in the accumulation of H₂S sewer gas at the end point near a manhole adjacent to the landfill.
- Evaluated the performance of granular activated carbon for the removal of odor from the headspace of the leachate treatment system.
- Assisted with sewer and discharge permit negotiations with the MWRD and the Illinois EPA.

Landfill Closure and Compliance Plan Services, Confidential

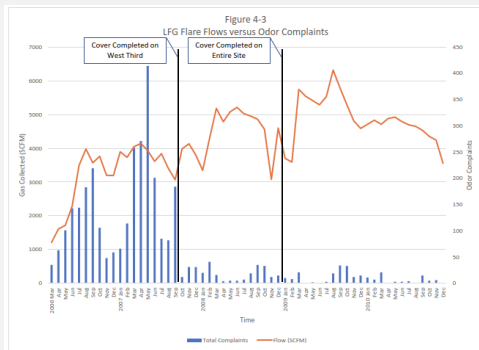

Client: Confidential

Services Provided:

- Gas Collection and Control System Design
- Landfill Cover System Design and CQA
- Odor Mitigation, Monitoring and Reporting
- Landfill O&M Services
- Expert Witness Testimony

Project Description

Project Objective

Geosyntec was retained by a confidential client to provide engineering and compliance services related to early engineered closure at a landfill. The consent order required development of a "Landfill Compliance Plan" to address site-specific challenges and potential problems based on the engineering understanding of the landfill environment. The Landfill Compliance Plan included the following Work Plans: Landfill Settlement, Landfill Gas and Air Quality, Landfill Monitoring and Corrective Action Plan, Leachate, Surface Water, Groundwater and Systems Identification.

Geosyntec's Scope of Services

Geosyntec personnel developed a Landfill Compliance Plan that included the various Work Plans that addressed different environmental monitoring and control systems. The Landfill Compliance Plan included both design and operational procedures to address fugitive emissions, below-grade landfill gas migration, leachate management, stormwater and settlement. The Compliance Plan also included development and implementation of an odor monitoring program to evaluate the effectiveness of the various work elements contained in the Landfill Compliance Plan.

Consent order reporting requirements included monthly reporting of leachate and landfill gas data, settlement, temperature, odor complaints and internal pressure data. The compliance plan required review and analysis of seven discrete issue areas, including: (1) landfill gas collection and control systems; (2) site wide order; (3) heat and pressure event; (4) off-site landfill gas migration; (5) landfill gas flares; (6) stormwater; and (7) leachate management. Geosyntec also provided expert witness services to address completion of consent order requirements and an odor lawsuit from surrounding residents.

Notable Accomplishments

- Approval of Landfill Compliance Plan within consent order timeline.
- Implementation and reporting under the Landfill Compliance Plan.
- Engineered closure of the landfill.
- Reduction in consent order reporting requirements.
- Expert report and litigation support services.

Former Mission Linen Supply, Ambassador Laundry Site | Santa Barbara, California



Client: Mission Linen

Services Provided:

- Vapor Intrusion Monitoring of Chlorinated Volatile Organic Carbon (CVOC) Contamination
- Engineering Design of Vapor Intrusion Mitigation System (VIMS)
- Permitting and Construction Oversight of VIMS installation
- Engineering Design of Soil Vapor Extraction (SVE) System
- Regulatory Support Services

Project Description

Geosyntec has been the technical lead on vapor intrusion (VI) assessment, mitigation and remediation efforts related to the Former Mission Linen, Ambassador Laundry Site since 2018. Geosyntec is responsible for annual VI monitoring, which includes soil gas, crawl space and indoor air sampling both on-Site, and at neighboring properties. Geosyntec's proactive approach has helped foster a strong and cooperative relationship with the Central Coast Regional Water Quality Control Board (CCRWQCB), the regulatory agency overseeing the project. Recently, Geosyntec led the effort to design and implement a vapor intrusion mitigation system (VIMS) to mitigate VI in a neighboring building. This effort required permitting through and/or cooperation with the Santa Barbara Air Pollution Control District (APCD), the City of Santa Barbara Planning Department, the City of Santa Barbara Building and Safety Department, and the Santa Barbara County Department of Environmental Health Services. Following successful implementation, Geosyntec is now in charge of operation, maintenance and monitoring (OM&M) of the VIMS. Concurrently with VIMS implementation, Geosyntec conducted a successful pilot test for soil vapor extraction (SVE) remediation at the Site. The VIMS system was designed to accommodate the future tie-in of SVE and Geosyntec is currently leading the permitting effort for the SVE tie-in.

Active and Closed Municipal Landfill Groundwater Compliance Consulting Services | Santa Barbara County, California



Client: County of Santa Barbara (COSB) Resource Recovery and Waste Management Division (RRWMD)

Services Provided:

- Compliance Monitoring and Reporting Support
- Geographic Information Systems Services
- Database Management
- 3-D Groundwater Modeling
- Water Treatment System Design
- Landfill Gas system evaluation, inspection, optimization and testing

Project Description

The County of Santa Barbara (COSB) operates one active landfill and manages long-term monitoring and remediation at four closed landfill sites, under the regulation of the Central Coast Regional Water Quality Control Board, CalRecycle, and the Santa Barbara County Air Pollution Control District. Each site operates under a site-specific Monitoring and Reporting Program (MRP), requiring groundwater sampling and analysis, landfill gas monitoring, and/or surface emissions monitoring, and must report monitoring results to the relevant overseeing agency.

Geosyntec's Scope of Services

Geosyntec manages the reporting scope of the five active and closed landfill sites' respective groundwater compliance monitoring and reporting programs. Routine services include analytical database management, geographic information systems (GIS) mapping, geospatial analysis for landfill surface emissions monitoring, data visualization, report compilation, as well as regulatory agency interfacing. Other recent non-routine services have included groundwater and leachate treatment system design, a landfill gas extraction system optimization workplan, and investigative order response for per- and polyfluoroalkyl substances (PFAS) sampling and reporting. Most recently, Geosyntec staff evaluated the Santa Ynez Airport Closed Landfill Gas System for functionality, effectiveness, and optimization. Geosyntec prepared a rebound testing workplan to the Central Coast Regional Water Quality Control Board that was accepted, and implemented the work plan scope. Geosyntec continues to evaluate vapor phase system operation and efficacy at other closed landfill sites to support RRWMD goals of right-sizing their systems to maximize efficiency and cost.

c. Staff

Organizational Chart

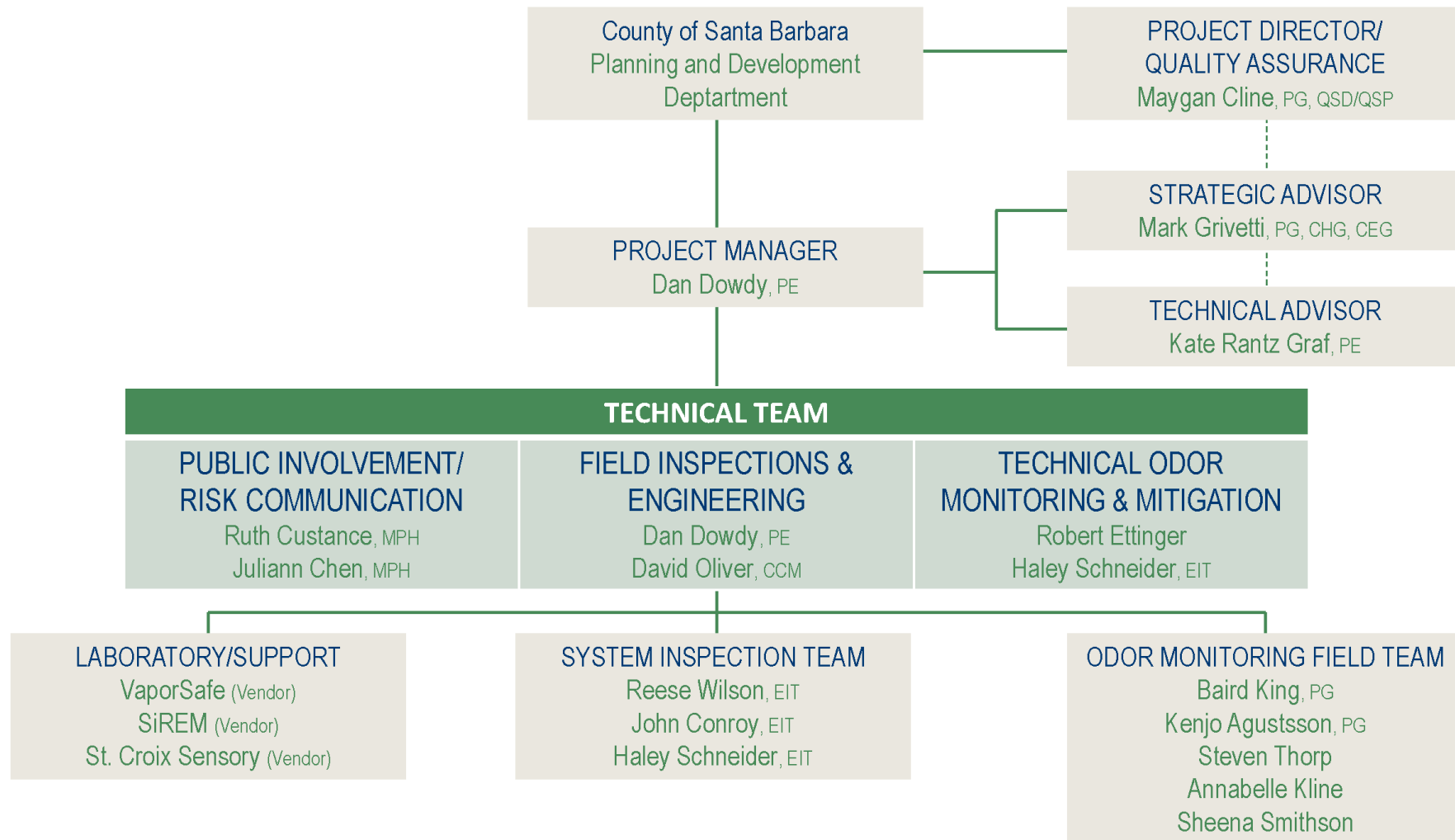

Key Staff Relevant Experience

Dan Dowdy, PE Project Manager



Role: Will serve as the “single-point-of-contact” for County staff managing assignments and work order/task orders under the contract. He will organize and manage the overarching responsibilities assigned to Geosyntec and foster the partnership with County and the community.

Dan will organize and coordinate the routine assignments and inspection calendar as well as limited notice assignments to efficiently execute inspections and reporting tasks depending on location and facility complexity. Dan will serve as the Geosyntec technical expert for operations and compliance and integrate closely with and guide the inspection team. He will review draft and/or final inspection report(s) along with developing and/or concurring with all recommend corrective actions to assist Cannabis operators to achieve compliance. Dan will be the coordinator for shared efforts with the Santa Barbara Air Pollution Control District including but not limited to material evaluations, as needed. Dan will refine and streamline Geosyntec efforts as the County program evolves, as lessons are learned, facilities complexities are compiled, and efficiencies are identified. Dan will be the internal point lead for evaluating emerging odor control technologies, proposed for improving existing project compliance and/or for future projects as initiated.

- *BS, Mechanical Engineering, University of California, Santa Barbara, 1992*
- *California Professional Engineer, Mechanical, No. M30559*

Mr. Dowdy is a Principal Mechanical Engineer based in Geosyntec Consultants Santa Barbara operations with a focus on characterization, field investigations, and remedial systems focused on vapor capture and emissions management. His vapor experience is focused on hazardous waste sites, including industrial and manufacturing sites, upstream and midstream petroleum, and other highly emissive facilities. He has vast experience managing systems and teams focused on vapor, water, and chemical management in the environmental arena. Mr. Dowdy is experienced with turnkey remedial solutions including process engineering and design; system installations including constructability analyses; engineered

system operations, monitoring, and performance optimization; off-grid power solutions; remote monitoring and data acquisition; instrumentation and controls; and is an expert at process troubleshooting (electrical and mechanical). Mr. Dowdy also has extensive experience in conducting feasibility studies, field investigations, construction management, preparing detailed cost analyses, and performance and compliance monitoring.

Maygan Cline, PG, OSD/QSP Project Director



Role: Responsible for client satisfaction and quality of project delivery to meet the County needs and objectives. As the Santa Barbara Branch Manager, she will allocate and commit the appropriate resources to the project. Additionally, she will monitor work quality alongside the project manager and notify

the County if any obstacles arise that could jeopardize the contract, project budget, or schedule.

- *BS, Geological Sciences, University of California, Santa Barbara, Santa Barbara, CA*
- *California Professional Geologist, No. 9117*
- *Qualified Stormwater Pollution Prevention Plan Developer and Practitioner (QSD/QSP): CA No. 27414*

Maygan Cline, PG, Branch Manager for Geosyntec Santa Barbara, Professional Geologist in California (CA), and program manager with extensive experience in California’s public and private sectors. Ms. Cline is experienced in contaminated site investigations and remediation, including investigation of emerging contaminants such as PFAS/PFOA. Additionally, Ms. Cline has extensive stakeholder engagement experience with the public, CA state and federal regulatory agencies. Ms. Cline’s local Santa Barbara project experience includes remedial investigation of historical petroleum and chlorinated solvent releases to soil and groundwater; site investigation and development of conceptual site models; remedial action design, planning, permitting and implementation. As well, Ms. Cline has managed compliance groundwater, surface-water and stormwater quality monitoring and reporting programs at local Santa Barbara County sites in sensitive areas including creeks and wetlands. Most recently, Ms. Cline has provided regulatory strategy support to COSB RRWMD staff related to the open

Tajiguas Landfill and four closed County-owned landfills. She has worked closely with county staff to develop and advance workflows to maximize efficiency and reduce costs for routine management tasks. Most recently, she has provided guidance to the County on regulatory requests related to the investigation of emerging contaminants, communicating potential risk and cost options for County consideration.

Kate Rantz Graf, PE
Technical Advisor



Role: Will serve as the technical advisor on cannabis odor monitoring. Kate is an expert in odor litigation and consulting.

- *BS, Chemical Engineering, Lehigh University, Bethlehem, PA*
- *Professional Engineer, Environmental, Delaware #20177*

Ms. Graf, a Principal with Geosyntec, specializes in providing air quality consulting services to industrial clients. She possesses more than 20 years of environmental engineering experience including regulatory compliance, permitting, and enforcement case resolution for industrial clients. Ms. Graf's past experience includes management of an air permitting division of a regulatory agency in the southwestern United States. She has assisted clients with obtaining major and minor source permits, including addressing New Source Review (NSR) and Prevention of Significant Deterioration (PSD) requirements, and compliance with new regulations. She has led compliance projects to enhance facility compliance and operational flexibility, to mitigate penalties for noncompliance, and to resolve alleged violations. She has supported clients to address odor issues and has served as a technical expert in litigation matters. She has performed environmental compliance testing and regulatory review of emission test results. Her regulatory background coupled with her industrial knowledge provide a unique perspective to effectively and efficiently resolve permitting, compliance, testing and enforcement issues on behalf of her clients.

Ruth Custance, MPH
Public Involvement/Risk Communication



Role: As an expert in risk assessment and air monitoring, she will provide expertise in public involvement and risk communication.

- *MPH, Environmental Health, University of Michigan School of Public Health, Ann Arbor, Michigan, 1989*
- *BA, Microbiology, University of California, San Diego, San Diego, CA, 1987*

Ruth has 32 years of experience specializing in multi-pathway risk assessment, data analysis, and risk communication. Much of her project experience includes conducting site assessments and risk assessments for complex high-profile sites in proximity to sensitive land uses. Her work has included developing programs to evaluate potential offsite emissions from these facilities considering adjacent residential or school-based land uses. Additional project experience includes evaluating indoor and outdoor air quality using air monitoring data and air dispersion modeling as needed. As a part of these projects, she has presented study findings regularly to governmental agencies as well as presented at public meetings.

David Oliver, CCM
Field Inspections & Senior Engineering Lead



Role: Certified Construction Manager and will provide technical expertise for field inspections and engineering.

- *BS, Construction Management, California Polytechnic State University, San Luis Obispo, CA*
- *Certified Construction Manager (CCM), Construction Management Association of America*

Mr. Oliver has more than 38 years of experience in general construction, demolition and environmental remediation, specializing in management, design build/value engineering, design review for constructability, problem resolution, contract administration, project controls, quality assurance/quality control (QA/QC). His experience includes projects in public utilities, soil and

groundwater remediation under CERCLA and RCRA, landfill leachate and landfill gas controls, landfill closure, the space and defense industries, and in dealing with local, state, and federal regulatory agencies. Past projects have included design and construction services for groundwater, leachate, and semi-conductor manufacturer wastewater treatment systems, building demolition, excavation and disposal of PCBs, VOC- and hydrocarbon-laden soils; installation of underground utility systems, mechanical and electrical system installation, and building construction.

Robert Ettinger

Technical Odor Monitoring & Mitigation



Role: As an expert in vapor emissions and fate and transport of organic chemicals, he will be responsible for odor monitoring and mitigation.

- *BS, Chemical Engineering, Rice University, Houston, Texas, 1986*
- *MS, Chemical Engineering, University of California, Berkeley, 1989*

Robert has 32 years of experience as an environmental specialist experience, including research, development and direct technical support to gasoline retail and distribution, petroleum pipeline, petrochemical manufacturing locations and waste sites. Much of Robert's work has focused on fate and transport of contaminants in the unsaturated zone including vapor emission estimation, soil vapor extraction system design, and subsurface methane and contaminant vapor migration to indoor air. He is also particularly experienced in human health risk assessment, litigation support, design and implementation of groundwater and soil vapor remediation systems, regulatory negotiation, and risk-based strategy development for environmental liability and business management. Mr. Ettinger is co-author of the Johnson and Ettinger (1991) algorithm for evaluating subsurface contaminant vapor intrusion to indoor air and has conducted field investigations and modeling evaluations on this topic for over a decade. He has published numerous articles on chemical vapor intrusion, environmental fate of volatile chemicals, and design considerations for groundwater and soil vapor extraction systems. Robert also brings a wealth of regulatory negotiation experience.

Mark Grivetti, PG, CHG, CEG

Strategic Advisor



Role: Mr. Grivetti will be available to support the team in all aspects of the project. In particular, Mr. Grivetti has considerable experience in supporting Santa Barbara County in Public Outreach and Litigation matters. In the event unforeseen issues arise, Mr. Grivetti will be able to leverage

his considerable experience with engineered vapor and odor systems and public engagement to advise the team on potential solutions.

- *MA, Geology University of California, Santa Barbara, 1982*
- *BA, Geology, University of California, Santa Barbara, 1979*
- *California Professional Geologist, No. 4272*
- *Certified Engineering Geologist, California, No. 1370*
- *Certified Hydrogeologist, California, No. 211*

Mr. Mark C. Grivetti, PG, CEG, CHG., Senior Principal Hydrogeologist has a diverse background in projects related to chemical characterization and remediation. He has extensive experience supporting Santa Barbara County including work at the Tajiguas, Ballard Canyon, Foxen Canyon landfills among other sites. Mr. Grivetti formerly served as Geosyntec's Program Manager and Service Group Manager for the Santa Barbara County MSA Program since 2001 and previously served in that role for Dames & Moore/URS. Of particular note, Mr. Grivetti has overseen many of Geosyntec's MSA projects for the County including recent work related to generation of waste acceptance criteria for the Tajiguas Landfill and plume stability work at Ballard Canyon Landfill. He has been recognized by courts as a technical expert including supporting Santa Barbara County as a testifying expert on several occasions. He has a proven track record of providing strategically sound solutions, responsive turnaround, and cost-effective work on these projects.

Estimated Staffing Hours

Estimated hours and staffing mix for Geosyntec cannabis odor compliance services are detailed by task in the table below. Geosyntec intends to utilize dedicated engineering inspection teams, and odor nuisance teams for routine field work, supported by more senior technical experts and advisors. Geosyntec senior personnel are prepared to mobilize to sites to support field teams if non-routine, or non-compliance needs warrant their on-site support. In general, Geosyntec aims to leverage early and mid-career staff for routine tasks, supported by the Project Manager and Senior Technical Advisors as needed and appropriate, to maximize efficiency and lower cost, while maintaining quality of delivery for the Department. For non-routine tasks, Geosyntec senior personnel and advisors may provide additional support or leadership relative to the task total effort to achieve Department objectives.

Estimated hours and % effort is presented in the table below, by task, for generalized grouping of staffing levels and expertise, for the 3-year contract term. Geosyntec assumes that strategic advisor involvement will be utilized on an as-needed basis, to efficiently address and solve the most complex odor-related issues the Department and cannabis operators face. Geosyntec endeavors to utilize the most efficient staffing mix possible, focusing on early and mid-career staff to perform routine site inspections and testing, with support from the Project Manager and Senior Field Inspection and Engineering Leads.

Task Descriptions	Early and Mid-Career Scientists & Engineers	Field Inspection Lead & Construction Manager	Project Manager/Senior Engineer	Strategic & Technical Advisors, as needed [†]
Task 1 - Initial Odor Control System Inspection, Testing and Reporting	875 hours or 61%	140 hours or 10 %	280 hours or 20%	140 hours or 10%
Task 2 - Quarterly Odor Control System Inspection, Testing and Reporting	1820 hours or 67%	280 hours or 10%	560 hours or 21%	70 hours or 3%
Task 3 - Review of Proposed OAP Changes and Confirmation Inspection	150 hours or 61%	24 hours or 10%	48 hours or 20%	24 hours or 10%
Task 4a -Odor Nuisance Complaint Response	204 hours or 81%	6 hours or 2%	24 hours or 10%	18 hours or 7%
Task 4b - Complex Odor Nuisance Complaint Response	324 hours or 77%	24 hours or 6%	24 hours or 6%	48 hours or 11%
Task 5 - Development of Recommendations in Cases of Non-Compliance	60 hours or 40%	30 hours or 20%	42 hours or 28%	18 hours or 12%
Task A - Department Coordination Meetings	0 hours or 0%	0 hours or 0%	29 hours or 50%	29 hours or 50%
Task B - Optional Periodic Summary Statistics Reporting to Support Department	144 hours or 50%	48 hours or 17%	48 hours or 17%	48 hours or 17%
Task C - Optional Technical or Non-Technical BOS or Public Stakeholder Meetings	36 hours or 22%	6 hours or 4%	48 hours or 30%	72 hours or 44%

*Note that site mobilization to north county areas may add additional mobilization time, up to 4-hours, roundtrip. Geosyntec will endeavor to schedule multiple site visits in a single day, in the same area, to the extent possible.

**If more than one mobilization is needed, 2-4 hours may be expended for each additional mobilization to achieve the desired Task 1 scope.

[†]Includes conservative estimates for strategic or technical advisor involvement. Strategic advisor and technical involvement will be utilized as necessary and managed efficiently, in close collaboration with Department input, to achieve desired objectives.

d. Study Methodology

Approach

Geosyntec understands the scope to include the tasks listed below, to effectively serve the Department's cannabis odor control systems, odor abatement plan monitoring, reporting and compliance assurance needs. Detailed descriptions for each task follow the list below.

- Task 1: Initial Odor Abatement Plan Compliance Inspection, Testing and Reporting
 - Task 1a: Oversight and inspection of system installation.
 - Task 1b: Inspection and/or testing of installed systems prior to startup and use.
- Task 2: Quarterly and Odor Control System Inspection, Testing and Reporting
 - Task 2a: Quarterly Odor Abatement Plan and system inspection, documentation and reporting to County.
- Task 3: Review of Proposed Odor Abatement Plan Changes and Confirmation Inspection
 - Task 3a: Assess the viability of odor abatement process changes proposed by Facility.
 - Task 3b: Follow-up inspections to ensure proposed changes have been approved and are in compliance with the Odor Abatement Plan.
- Task 4: Response to Odor Nuisance Complaints
 - Task 4a: Limited notice site mobilization, system inspection and compliance evaluation.
 - Task 4b: Limited notice complex odor nuisance complaint response site mobilization, system inspection and compliance evaluation, including real-time sampling, as needed.
- Task 5: Development of Recommendations in Cases of Non-Compliance
 - Task 5: Preparation of recommended changes to Odor Abatement Plan or systems, as warranted or appropriate.
- Task A: Department Coordination Meetings
 - Periodic Department meetings as outlined in Q&A response to the RFP.
- Optional Task B: Optional Periodic Summary Statistics Reporting to Support Department
 - Preparation of short summary memo with supporting summary tables and graphics for the reporting period, for Department use.
- Optional Task C: Technical Support at BOS and/or Public Stakeholder Meetings
 - Geosyntec support to County at BOS Meetings, and/or Public Stakeholder Meetings.

Initial site inspections will confirm that the cannabis operation is complying with their approved OAP. Those initial site visits will be conducted by experienced local engineering staff either during installation of the approved OAP system, or after it's installation but prior to system startup and use. Those site inspections will confirm that the OAP system equipment, componentry, odor-neutralizers, misters, etc., are installed in accordance with the approved OAP. If the operation is not compliant with the approved OAP, Geosyntec will collect photos and detailed field notes to support preparation of recommended compliance actions.

The compliance status will be communicated to the Department, and upon receipt of Department concurrence with Geosyntec's recommended compliance actions, those actions will be communicated to the cannabis operator to support their path to compliance. Additional site visits will be conducted to confirm the recommended compliance actions are implemented appropriately until the operator is determined compliant with their approved OAP. Once compliance is established, routine quarterly OAP compliance inspections will be conducted to confirm the systems continue compliant operations.

Additionally, odor monitoring will be required at various stages of startup and operational phases at each location. We envision several types of odor monitoring may be needed including real-time monitoring using the human nose and a field olfactometer, near real-time monitoring using a field gas chromatograph measuring terpenes, and laboratory analysis with a sensory lab using an odor panel.

We anticipate that real-time monitoring using a field olfactometer will be a primary tool used to assess odors. Air sample collection and analysis can be used for detailed analysis at locations where odor complaints are received or where the Department requests additional evaluation. The laboratory used for the detailed evaluation will be dependent on site-specific factors and the desired scope of the analyses. Laboratories that may be used for the evaluation include VaporSafe and St. Croix Sensory. VaporSafe can provide on-site discrete and/or continuous sampling for terpenes to assist in the evaluation of odor sources and/or deficiencies in odor mitigation measures above those determined with the field olfactometer.

A primary resource for field measurements will be obtained using a Nasal Ranger® Olfactometer (Nasal Ranger) supplied by St. Croix Sensory, Inc. (St. Croix). The Nasal Ranger® creates a calibrated series of discrete dilutions by mixing the odorous ambient air with odor-free, carbon-filtered air. Each discrete dilution level is defined as a "Dilution-to-Threshold" (D/T) ratio and is a measure of the number of dilutions needed to make the odorous ambient air "non-detectable". Higher values for D/T indicate higher odors. Typical background D/T values are range from 8 to 12 D/T which can be used to compare readings around a facility. Another use of the Nasal Ranger® can be in ascertain the effectiveness of control strategies.

St. Croix laboratory may also be utilized for odor panel analysis for comparison to field measurements. An odor panel is a group of trained odor assessors that characterize the odor with respect to odor strength, intensity, persistence, and hedonic tone. The odor panel can provide additional information on the characteristics of an odor and its intensity.

Task 1: Initial Odor Control System Inspection, Testing and Reporting

For cannabis operations with approved Odor Abatement Plans (OAPs), Geosyntec will provide oversight, inspections and testing of cannabis odor control monitoring and mitigation systems either:

- a. during their construction and installation, or
- b. prior to system startup and use,

To confirm the system componentry, construction and installation are compliant with the specifications indicated in the approved OAP. Geosyntec will document the oversight, inspections and/or testing in a standardized form that will be developed with the Department to capture key details and information to support County needs. An example inspection form is included as **Attachment B** for the Department's consideration and will be modified based on the Department's feedback prior to use.

Additional details describing Geosyntec approach to oversight of system installation activities, versus inspection and testing of systems prior to their startup and use, are provided below.

Task 1a: Oversight and Inspection of System Installation

Upon receipt of approved OAP's and confirmation from the Department to proceed, Geosyntec will coordinate with cannabis operators prior to, or during, odor abatement system installation to schedule a system inspection. The inspection will observe system installation and/or construction activities, with respect to the approved OAP. Oversight and/or inspection will document the items below, at a minimum:

- Name and address of operator,
- Date and time of system inspection,
- Name and phone number of site contact,
- Version of approved OAP used to support the system inspection,
- Written description and supporting photos of activities observed during inspection including but not limited to:
 - construction or installation activities,
 - name of contractor company,
 - confirmation that the proposed system type and condition of equipment being installed, align with the approved OAP,
 - confirmation of system arrangement and alignment with the approved OAP, including location and number of systems,
 - confirmation that construction plans have been approved by the local jurisdiction (e.g. City or County Building and Safety) and observations of conformance with the approved plans (as needed or appropriate), and
 - other general systems observations.
- Determination of compliant or non-compliant installation in accordance with the approved OAP. Optional real-time communication of compliance status to the operator during or at the end of the system inspection.

For non-compliant installation observations, Geosyntec will document the details of the non-compliant items observed for the County, including but not limited to:

- Detailed written notes and comments with supporting photos of the non-compliant installation items, relative to the approved OAP, and
- Recommended actions to support the Cannabis operator to achieve compliance.

As an option for the Department's consideration, Geosyntec can communicate non-compliant observations and recommendations to achieve compliance to the operator contact during the site visit. This real-time communication may support both the Department and operator understanding of compliance status, and potentially expedite operator implementation of recommended actions and support them in achieving compliance.

Completed oversight or inspection forms (**Attachment B**) will be submitted to the Department via email, and/or uploaded to a secure Microsoft SharePoint site. Geosyntec can create the SharePoint site and provide access to Department staff, for the purpose of: organizing collected information in a consistent manner, eliminating unnecessary emails that the Department has to manage, and providing all cannabis odor related compliance information in a single location for Department ease of access and use.

Task 1b: Inspection and/or Testing of Installed Odor Mitigation Systems Prior to Startup and Use.

Alternatively, if Geosyntec does not oversee system installation, Geosyntec will coordinate with cannabis operators to schedule system inspections and testing prior to their startup and use. Geosyntec will inspect, test, and document the system components in accordance with their approved OAP, including but not limited to:

General Data

- Final construction inspections and complete permits have been signed off by the local jurisdiction (e.g., Building and Safety division),
- Community notifications have been completed,
- System general arrangement aligns with proposed plans including location and number of systems,
- System integrity and tightness testing has been completed where applicable,
- Validation that the proposed system methods, products and substances are being utilized (e.g., component branding, carbon filter types, and neutralizing agents),
- Operation and maintenance protocols and documentation processes are in place,
- Abatement system operator training and competency is complete,
- SCADA and/or PLC system has been commissioned, if applicable,
- System(s) functionality testing, and validation is complete (e.g., fail safes and alarms),

Flow Measurements

- Air flows are a critical variable for adsorption and filtration systems. Operating at low flows below the design criteria may create conditions insufficient for adequate odor removal, and too high a flow may create conditions exceeding residence time or filtration capacities. Due to the variability of systems designs, Geosyntec has multiple approaches to validate design air flows using monitoring devices such as multifunction HVAC meters with and without shrouds, hot wire anemometers, and pitot tubes. One or multiple of these tools can be utilized to validate systems flows.
- Similar to air flow, low flow rates and/or pressures in liquid-based odor-neutralizing compounds can create inefficiencies in droplet size and dispersion. Onsite evaluation of the output of liquid-based odor-neutralizing compounds will also have a variable approach depending on the facility. In the event the system does not utilize inline flow measuring devices, Geosyntec would likely make recommendations to the facility to augment the system with flow meters or in-line rotameters to streamline future inspections. Should additional testing be necessary at the time of inspection, Geosyntec can deploy several approaches to measure in-line flows including portable ultrasonic mass flow meters, engineering analysis of pressures versus misting head design, and possible temporary in-line flow measurement tools.

System Efficiency

At the initiation of system operations, validation of system can be determined using several approaches, the most appropriate to be determined by the facility system. The general approach for several scenarios are described below.

- For carbon adsorption systems the Nasal Ranger® will be used to measure the D/T values of air at the inlet and outlet of the treatment unit to determine the treatment efficiency is meeting the unit goals.

- For odor neutralizing systems such Byers vapor phase system with Ecosorb, Nasal Ranger® measurements will be taken in the interior and at the exterior of the greenhouse to confirm adequate odor control.
- Nasal Ranger® measurements will be taken at the upwind and downwind perimeter of the facility to confirm adequate odor control.

For non-compliance observations, Geosyntec will collect photos and notes of the non-compliance items, if observed, and will develop a list of recommended actions to support the cannabis operator to achieve compliance. The list of recommendations will be provided to the Department within in the non-compliance section of the inspection form (**Attachment B**) and will be discussed with the Department via teleconference.

Task 2: Quarterly Odor Control System Inspection, Testing and Reporting

For cannabis operations with approved OAPs and systems, Geosyntec will conduct quarterly site and system inspections to confirm the systems continue to operate in accordance with the approved OAP.

Geosyntec will review the approved Odor Abatement Plan and system details prior to the site inspection and will bring a copy of the approved plan to support the inspection. Geosyntec will document details from the site visit in a standardized inspection form to validate the systems continue to meet the specifications and operational methodologies outlined in the OAP. At minimum, the following will be evaluated:

- Complaint tracking system and documentation is current and retained for the required 5 year minimum,
- Odor complaint contact is available and assigned odor abatement staff are on-site (if applicable),
- Deviations from the OAP have not been implemented unless approved by the Department (e.g. cultivation area, odor abatement system(s) products and substances),
- General visual inspection and operating condition of the componentry including odor control technology and meteorological station,
- Review of maintenance records in alignment with manufacturers recommendations,
- Consumable material utilization rates are recorded meet proposed schedules,
- Documentation of odor monitoring activities and response actions,
- Conducting an odor survey using the Nasal Ranger® as discussed in Task 1 dependent on the type of odor control technology being used.

Task 3: Review of Proposed OAP Changes and Confirmation Inspection

Depending on the results and findings gathered during site inspections, the facility may propose immediate or long-term changes to their OAP(s). The Geosyntec team will review the proposed OAP changes as expeditiously as possible. Geosyntec's primary goal will be supporting and assisting the facility in their proposals. If the proposed changes are in alignment with the approved OAP and will likely provide the same or better level of odor control, concurrence would be conveyed to the facility in an expedited fashion, upon receipt of concurrence from the Department. Once changes are implemented, Geosyntec will schedule a site visit to inspect and document the appropriate changes were implemented, similar to the level of effort described for Task 1b.

Should the proposed changes require modifications to the approved OAP, Geosyntec staff will notify the Department and will schedule a teleconference to discuss, as appropriate.

Task 4a: Odor Nuisance Complaint Response

Geosyntec will coordinate closely with the Department to respond to odor complaints within limited timeframes. We will develop an internal on-call schedule to ensure staff is available with testing, monitoring equipment and supplies staged for quick deployment. Our field staff base is centered in downtown Santa Barbara and surrounding areas, providing the ability for quick response.

Utilizing information gathered by the Department surrounding the complaint, Geosyntec staff will mobilize to the physical location specified in the complaint and conduct field measurements using the Nasal Ranger® at the location associated with the complaint, and at several locations surrounding area. An iterative process will be utilized to determine to possible source of the odors by evaluating site meteorological data relevant to the timing of the reported odors to help narrow and isolate the location of the complaints with respect to recorded wind direction and wind speed.

At each location where an odor reading is collected, the sampler will inhale into the Nasal Ranger®. The first measurement will be collected at a D/T ratio of 60. The measurements will be repeated at D/T ratios of 30, 15, 7, 4, and 2 until the odor is non-detectable. The D/T ratio below which the odor is non-detectable is the odor concentration in Odor Units (OU) for that sample. The odor sampling locations will be recorded on a location map. An example odor sampling form included in **Attachment B** will be completed at each location to document the time of sampling, odor characteristics, concentration in OU, location, and meteorological conditions.

For systems and sites that are determined to be operating in compliance with their approved OAP, Geosyntec anticipates that these responses will be streamlined and less than ½-day in duration.

Task 4b: Complex Odor Nuisance Complaint Response

During odor nuisance complaint response, if Geosyntec determines the site or system is not in compliance or is complying but odors persist, additional data collection or evaluation may be warranted and/or requested by the Department and/or the cannabis operator in an attempt to support the operator to achieve compliance. In addition to the approach outlined for Task 4a and the use of the Nasal Ranger®, onsite analysis of terpenes can be conducted.

The number of samples and sampling period will be determined based on the site-specific conditions. For purposes of this proposal, it is assumed that samples will be collected at two upwind and four downwind locations for a study duration of 24 to 48 hours and analyzed by an onsite laboratory. With this scheme it is anticipated that a sample location will be sampled once each hour over the sample period. The results of the sampling will be evaluated with respect to meteorological conditions over the time period to facilitate understanding of emissions over different parts of the day and different meteorological conditions. This information will be correlated with specific facility activities over the course of the samples period to identify if the odor is a result of a particular activity. Based on these data, recommendations will be made for facility modifications.

Geosyntec staff will determine if single or multiple facilities may be considered for inspection depending on the locale of nearby facilities in relation to meteorological data and variables. In general, site inspection procedures will mimic those outlined in *Task2 - Quarterly and Non-Routine Inspections*.

Task 5: Development of Recommendations in Cases of Non-Compliance

Depending on the circumstances causing a non-compliance event, recommendations for system changes or improvements may be identified and/or warranted. During response to a nuisance complaint, Geosyntec staff will determine the root cause of the odor complaint, and work with the facility to determine if mitigations have been implemented in alignment with the facility respective odor response protocol. Depending on the conclusions of the non-compliance monitoring and site inspection, Geosyntec will work with the facility to develop recommended actions. In most cases, initial recommendations will be developed in close coordination with facility. These may be immediate actions within the scope of the respective Odor Abatement Plan, or longer-term overarching technological changes in alignment with emerging best available odor control technologies. Recommendations will be developed and presented as a separate technical document dovetailing with the respective site inspection findings.

Task A: Department Coordination Meetings

As outlined in the Q&A response to the RFP, this task encompasses weekly meetings for the first quarter of the contract period (12-meetings), tapering to monthly meetings (9-meetings), then to quarterly frequency (8-meetings) as the inspection program is established. A total of 29 meetings are assumed.

Optional Tasks for County Cannabis Odor Compliance

Optional Task B: Preparation of Periodic Cannabis Odor Control Compliance Summary Reports

Clear and effective communication is critical to developing an open and collaborative process among the various involved stakeholders, including County, the County's BOS, cannabis operators and interest groups, and public stakeholders. Geosyntec can prepare periodic summary reports for submittal to the Department that describe the nature of odor complaints received from the public, odor abatement compliance inspections, monitoring efforts and findings, and recommendations for corrective actions in response to any instances of non-compliance that may be documented during the routine inspections. Such reports could prove to be very useful in demonstrating the importance and effectiveness of the Department's efforts to effectively manage cannabis odor compliance and provide an important tool in helping communicate these efforts to the various stakeholder groups.

Geosyntec recommends that a template for periodic reporting be developed in conjunction with the Department. This template would conceptually include summary information for the reporting period, including, for example:

- The number, location, and identifying information for submitted and/or approved OAP's;
- The number, nature and location(s) of OAP inspections, monitoring or testing activities performed and documented;
- Summary of findings from odor nuisance complaint inspections, monitoring or testing activities performed. The summaries would include the number, location, and specific nature of compliant of non-compliant facilities; and,
- The nature and status of compliance enhancement recommendations.

The use of a pre-approved reporting template would streamline the periodic reporting process, allow for concise and consistent information presentation, and provide the Department with regularly updated documentation regarding the status of the Cannabis Odor Control Systems and Odor Abatement Plan Monitoring, Reporting and Compliance Assurance program. Geosyntec has the capability to automate the

template reporting in the field which can streamline compilation of data and preparation of summary reports at key intervals. Field reporting typically occurs on tablets with the input data directly downloaded in the office for report preparation.

In addition, Geosyntec is prepared to work with the Department staff to understand potential summary reporting needs, including graphics and project statistics, on a quarterly, semi-annual, annual, or as needed basis. For example, Geosyntec can prepare summary graphics which will show the locations of the complaints/inspections, recurrence, timing etc. Summary statistics with supporting visual aids related to type and number of complaints received, method complaints were submitted, location and seasonal variability of complaints, typical response time to complaints, response findings to complaints, etc. can also be provided in presentation, memo or other format deemed useful for COSBP&D needs.

Optional Task C: Technical Support at BOS and/or Public Stakeholder Meetings

Geosyntec Support to County at BOS Meetings

Geosyntec is well positioned to support the Department by assisting staff with presentations at BOS or other key meetings. Our local staff assigned to this project have long track records of making presentations or assisting clients with summary reporting and/or technical reporting in similar venues. In our experience, the key to successful presentations is to work with our clients to understand the level of detail needed by the stakeholder and tailor the presentation accordingly. Our local staff also have the capability to prepare compelling graphics to illustrate key facts and conclusions to support the Department. We stand prepared to back the efforts of the Department and applicants to comply with local Cannabis odor regulations and assist the Department staff in reporting on the findings.

Geosyntec Support to County at Public Stakeholder Meetings

Similarly, Geosyntec will support the Department at Public Stakeholder meetings as needed. We will work with the Department staff to understand the stakeholder issues and help design presentations that are factual and clear. Our staff routinely are asked to prepare creative graphics that convey complex issues in a format that is clear and understandable. Staff assigned to this project have long track records of similar presentations, including presentations at highly charged public meetings.

e. References

County of Santa Barbara (County) Resource Recovery and Waste Management Division (RRWMD)

Jeanette Gonzales-Knight, PE | *Compliance Manager*

Office: (805) 882-3627

*See project description on page 12.

Southern California Gas Company

Darrell Johnson | *Manager Environmental Programs*

Office: (213) 244-2142

*See project description on page 7.

Ascon Landfill Site

Tamara Zeier, PE | *Project Director*

Office: (714) 388-1804

*See project description on page 6.

Former Mission Ambassador Laundry Site, Santa Barbara, California

Donald Moore, PG | *Environmental Consultant point of contact for Mission Linen*

Office: (415) 566-0300

*See project description on page 11.

f. Attachments

Attachment A- Certificate of Insurance

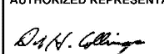
Client#: 25361		GEOSCONS		DATE (MM/DD/YYYY) 3/25/2021															
ACORD CERTIFICATE OF LIABILITY INSURANCE																			
THIS CERTIFICATE IS ISSUED AS A MATTER OF INFORMATION ONLY AND CONFERS NO RIGHTS UPON THE CERTIFICATE HOLDER. THIS CERTIFICATE DOES NOT AFFIRMATIVELY OR NEGATIVELY AMEND, EXTEND OR ALTER THE COVERAGE AFFORDED BY THE POLICIES BELOW. THIS CERTIFICATE OF INSURANCE DOES NOT CONSTITUTE A CONTRACT BETWEEN THE ISSUING INSURER(S), AUTHORIZED REPRESENTATIVE OR PRODUCER, AND THE CERTIFICATE HOLDER.																			
IMPORTANT: If the certificate holder is an ADDITIONAL INSURED, the policy(ies) must have ADDITIONAL INSURED provisions or be endorsed. If SUBROGATION IS WAIVED, subject to the terms and conditions of the policy, certain policies may require an endorsement. A statement on this certificate does not confer any rights to the certificate holder in lieu of such endorsement(s).																			
PRODUCER Greyling Ins. Brokerage/EPIC 3780 Mansell Road, Suite 370 Alpharetta, GA 30022				CONTACT NAME: Carly Underwood PHONE (A/C, No, Ext): 770.670.5324 FAX (A/C, No): E-MAIL ADDRESS: carly.underwood@greyling.com															
INSURED Geosyntec Consultants, Inc. 900 Broken Sound Parkway NW, Suite 200 Boca Raton, FL 33487				<table border="1"> <thead> <tr> <th>INSURER(S) AFFORDING COVERAGE</th> <th>NAIC #</th> </tr> </thead> <tbody> <tr> <td>INSURER A : National Union Fire Ins. Co.</td> <td>19445</td> </tr> <tr> <td>INSURER B : Aspen American Insurance Company</td> <td>43460</td> </tr> <tr> <td>INSURER C : Allied World Assurance Company (U.S.)</td> <td>19489</td> </tr> <tr> <td>INSURER D : New Hampshire Ins. Co.</td> <td>23841</td> </tr> <tr> <td>INSURER E :</td> <td></td> </tr> <tr> <td>INSURER F :</td> <td></td> </tr> </tbody> </table>		INSURER(S) AFFORDING COVERAGE	NAIC #	INSURER A : National Union Fire Ins. Co.	19445	INSURER B : Aspen American Insurance Company	43460	INSURER C : Allied World Assurance Company (U.S.)	19489	INSURER D : New Hampshire Ins. Co.	23841	INSURER E :		INSURER F :	
INSURER(S) AFFORDING COVERAGE	NAIC #																		
INSURER A : National Union Fire Ins. Co.	19445																		
INSURER B : Aspen American Insurance Company	43460																		
INSURER C : Allied World Assurance Company (U.S.)	19489																		
INSURER D : New Hampshire Ins. Co.	23841																		
INSURER E :																			
INSURER F :																			
COVERAGES		CERTIFICATE NUMBER: 21-22		REVISION NUMBER:															
THIS IS TO CERTIFY THAT THE POLICIES OF INSURANCE LISTED BELOW HAVE BEEN ISSUED TO THE INSURED NAMED ABOVE FOR THE POLICY PERIOD INDICATED. NOTWITHSTANDING ANY REQUIREMENT, TERM OR CONDITION OF ANY CONTRACT OR OTHER DOCUMENT WITH RESPECT TO WHICH THIS CERTIFICATE MAY BE ISSUED OR MAY PERTAIN, THE INSURANCE AFFORDED BY THE POLICIES DESCRIBED HEREIN IS SUBJECT TO ALL THE TERMS, EXCLUSIONS AND CONDITIONS OF SUCH POLICIES. LIMITS SHOWN MAY HAVE BEEN REDUCED BY PAID CLAIMS.																			
INSR LTR	TYPE OF INSURANCE	ADDL SUBR INSR WVD	POLICY NUMBER	POLICY EFF (MM/DD/YYYY)	POLICY EXP (MM/DD/YYYY)	LIMITS													
A	<input checked="" type="checkbox"/> COMMERCIAL GENERAL LIABILITY <input type="checkbox"/> CLAIMS-MADE <input checked="" type="checkbox"/> OCCUR GEN'L AGGREGATE LIMIT APPLIES PER: <input type="checkbox"/> POLICY <input checked="" type="checkbox"/> PRO-JECT <input checked="" type="checkbox"/> LOC OTHER:		GL5268179	04/01/2021	04/01/2022	EACH OCCURRENCE \$1,000,000 DAMAGE TO RENTED PREMISES (Ea occurrence) \$500,000 MED EXP (Any one person) \$25,000 PERSONAL & ADV INJURY \$1,000,000 GENERAL AGGREGATE \$2,000,000 PRODUCTS - COMP/OP AGG \$2,000,000 \$													
A	<input checked="" type="checkbox"/> AUTOMOBILE LIABILITY <input checked="" type="checkbox"/> ANY AUTO OWNED AUTOS ONLY <input checked="" type="checkbox"/> HIRED AUTOS ONLY <input type="checkbox"/> SCHEDULED AUTOS NON-OWNED AUTOS ONLY		CA4489673 (AOS) CA4489674 (MA)	04/01/2021	04/01/2022	COMBINED SINGLE LIMIT (Ea accident) \$2,000,000 BODILY INJURY (Per person) \$ BODILY INJURY (Per accident) \$ PROPERTY DAMAGE (Per accident) \$ \$													
B	<input type="checkbox"/> UMBRELLA LIAB <input checked="" type="checkbox"/> EXCESS LIAB <input checked="" type="checkbox"/> OCCUR <input type="checkbox"/> CLAIMS-MADE		CX005GA21	04/01/2021	04/01/2022	EACH OCCURRENCE \$5,000,000 AGGREGATE \$5,000,000 \$													
D	<input checked="" type="checkbox"/> WORKERS COMPENSATION AND EMPLOYERS' LIABILITY ANY PROPRIETOR/PARTNER/EXECUTIVE OFFICER/MEMBER EXCLUDED? (Mandatory in NH) If yes, describe under DESCRIPTION OF OPERATIONS below		WC015893709 (AOS)	04/01/2021	04/01/2022	<input checked="" type="checkbox"/> PER STATUTE <input type="checkbox"/> OTHER E.L. EACH ACCIDENT \$1,000,000 E.L. DISEASE - EA EMPLOYEE \$1,000,000 E.L. DISEASE - POLICY LIMIT \$1,000,000													
A			WC015893710 (CA)	04/01/2021	04/01/2022														
C	<input checked="" type="checkbox"/> Prof Liab (PL)/ Contr. Poll (CPL)		03122723	04/01/2021	04/01/2022	Each Act \$5,000,000 Aggregate \$5,000,000													
DESCRIPTION OF OPERATIONS / LOCATIONS / VEHICLES (ACORD 101, Additional Remarks Schedule, may be attached if more space is required)																			
CERTIFICATE HOLDER			CANCELLATION																
Sample Certificate			SHOULD ANY OF THE ABOVE DESCRIBED POLICIES BE CANCELLED BEFORE THE EXPIRATION DATE THEREOF, NOTICE WILL BE DELIVERED IN ACCORDANCE WITH THE POLICY PROVISIONS. AUTHORIZED REPRESENTATIVE 																

© 1988-2015 ACORD CORPORATION. All rights reserved.

Attachment B-Inspection Log Example

CANNABIS ODOR ABATEMENT SYSTEMS INSPECTION RECORD

Document Control No. _____

Sheet No. 1 of

COMPLIANT _____

NON-COMPLIANT _____

<u>PROJECT (NAME/NO.):</u>	<u>PHASE & TASK NO.:</u>
<u>OPERATOR NAME & ADDRESS:</u>	
<u>VERSION OF APPROVED OAP USED (Title and Date):</u>	
<u>REASON FOR INSPECTION:</u>	
<u>DATE:</u>	<u>ARRIVAL TIME:</u>
	<u>DEPARTURE TIME:</u>
<u>WEATHER: SKY</u>	<u>TEMP. (°F/°C)</u>
<u>PRESSURE</u>	<u>WIND SPEED</u>
	<u>WIND DIRECTION</u>
<u>VERSION OF OAP USED (Title and Date):</u>	
<u>DESCRIPTION OF ACTIVITIES PERFORMED:</u>	

ON-SITE PERSONNEL	AFFILIATION
<u>INSPECTOR(S)</u>	
<u>OPERATOR(S)</u>	
<u>OTHER(S) specify</u>	
INSPECTION FINDINGS	
<u>ODOR ABATEMENT SYSTEM TYPE(S): (Describe or None)</u>	
<u>SYSTEM TYPE(S) CONSISTENT WITH APPROVED OAP (Yes / No)</u>	
<u>SYSTEM(S) CONSTRUCTION PLANS APPROVED BY LOCAL JURISDICTION? (Yes / No)</u>	
<u>SYSTEM CONDITION AND STATUS: (Describe; Operating / Not Operating / Out of Service)</u>	
<u>SYSTEM MODIFICATIONS SINCE LAST INSPECTION: (Yes / No; Describe or Unknown)</u>	

INSPECTION FINDINGS (continued)

Document Control No. _____

Sheet No. 2 of _____

PRIOR NON-COMPLIANCE EVENT(S)? (Yes / No: if Yes, provide date & description)

PRIOR NON-COMPLIANCE EVENT(S) ADEQUATELY ADDRESSED? (Yes / No / Not applicable)

SYSTEM EFFECTIVELY ABATING ODORS? (Yes/No; if no, describe/characterize odors)

TESTING OR MONITORING CONDUCTED? (Describe method(s), equipment, and measurements)

SAMPLES COLLECTED? (Yes / No: if Yes, list type, Sample IDs and scheduled test methods)

RECOMMENDED ACTIONS:

COMMENTS:

OTHER:

NAME: _____ PROJECT NO.: _____ HOURS ONSITE: _____

Odor Monitoring Data Collection Form

Date: _____

Time	Location	D/T							Descriptors	Comments
		60	30	15	7	4	2	<2		

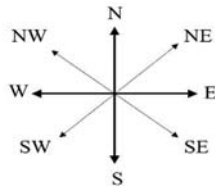
Weather Conditions <input type="checkbox"/> Sunny <input type="checkbox"/> Partly Cloudy <input type="checkbox"/> Mostly Cloudy <input type="checkbox"/> Overcast <input type="checkbox"/> Hazy	Precipitation: <input type="checkbox"/> None <input type="checkbox"/> Fog <input type="checkbox"/> Rain <input type="checkbox"/> Sleet <input type="checkbox"/> Snow	Wind Direction Blowing From: (circle one) 	Wind Speed: <input type="checkbox"/> Calm <input type="checkbox"/> Light Breeze (1-5 mph) <input type="checkbox"/> Moderate Wind (5-15 mph) <input type="checkbox"/> Strong Wind (15 or higher mph)
---	--	--	--

Temp: °F/°C Relative Humidity: % Barometric Pressure: _____

Comments:

Code	Name	Signature
------	------	-----------

GEOSYNTEC CONSULTANTS
Photographic Record



Client:

Project Number:

Site Name:

Site Location:

[Photograph ID/Number]

Date:

Direction:

Comments:

[Photograph ID/Number]

Date:

Direction:

Comments:

GEOSYNTEC CONSULTANTS
Photographic Record



Client:

Project Number:

Site Name:

Site Location:

[Photograph ID/Number]

Date:

Direction:

Comments:

[Photograph ID/Number]

Date:

Direction:

Comments:

Attachment C-Example Inspection, Testing and Monitoring Report

Geosyntec 
consultants

Prepared for:
County of Santa Barbara
Planning and Development Department
123 East Anapamu Street
Santa Barbara, CA 93101

INSPECTION, TESTING AND MONITORING REPORT

Project Site XXX
Carpinteria, California

Prepared by:

Geosyntec 
consultants

engineers | scientists | innovators

924 Anacapa Street, Suite 4A
Santa Barbara, CA93101

Project Number: XXX

June 2022

TABLE OF CONTENTS

1. INTRODUCTION 1-1
 1.1 Facility Overview 1-1
 1.2 Report Organization 1-1

2. SYSTEM OPERATION 2-1
 2.1 System Installation Inspection 2-1
 2.2 System Start-Up Phase 2-2
 2.3 Additional Monitoring When Odors Present 2-4

3. DISCUSSION AND CONCLUSIONS 3-6

EXAMPLE

LIST OF TABLES

Table 1: Summary of Field Olfactometer Readings

Table 2: Summary of Terpene Compound Monitoring

LIST OF FIGURES

Figure 1: Vicinity and Site Location Maps

Figure 2: Site Layout

Figure 3: Air Treatment System Process Flow Diagram

LIST OF APPENDICES

Appendix A: Inspection Forms

Appendix B: Laboratory Reports

Appendix C: Facility Odor Abatement Plan

1. INTRODUCTION

This report presents the results of inspection testing and monitoring of the XXXX Facility located at XXXXX, Carpinteria California (Figure 1). The report includes the evaluation of the air treatment system (System) operations through the end of the start-up period (XXX, 2022 through XXX, 2022) and the quarterly inspection System testing and monitoring for the period from XXX through XXX, 2022. This Report documents the compliance with the facility Odor Abatement Plan (OAP) and presents the testing results for the System.

On behalf of the County of Santa Barbara Planning and Development Department (Department) this document was prepared by Mr. Dan Dowdy and Mr. David Oliver, and was reviewed by Ms. Maygan Cline, each of Geosyntec Consultants, Inc. (Geosyntec) in accordance with the internal review policy of the firm.

1.1 Facility Overview

This section includes a brief description of the location and layout of the facility with figures depicting the surrounding landuse and site plan.

A listing of the air treatment system components is provided based on the facility OAP.

For this example, a carbon-based system is assumed to be used in the warehouses and the Byers vapor phase system with Ecosorb CNB 107 in greenhouses.

.

1.2 Report Organization

The remainder of this Report is organized into the following sections:

- Section 2, “*System Operation,*” in which the System operation activities for the start-up period are described and the data presented;
- Section 3, “*System Monitoring,*” in which the vapor monitoring data collected from various components are presented; and
- Section 4, “*Discussion and Conclusions.*”

2. SYSTEM OPERATION

2.1 System Installation Inspection

The OAP was approved by the Department on XXXX, 2022. The initial inspection was conducted on XXXX, 2022 prior to startup and included Geosyntec personnel observation of system installation and testing. The inspection documented and included the items below:

- Name and address of operator,
- Date and time of system inspection,
- Name and phone number site contact,
- Version of approved OAP used to support the system inspection,
- Written description and supporting photos of activities observed during inspection including but not limited to:
 - construction or installation activities,
 - name of contractor company,
 - proposed system type and condition of equipment being installed, relevant to the approved OAP,
 - system general arrangement aligns with proposed plans including location and number of systems,
 - Construction plans have been approved by the local jurisdiction (e.g. Building and Safety division) and observations of conformance with the approved plans (as needed or appropriate), and
 - other general systems observations.
- Determination of compliant or non-compliant installation in accordance with the approved OAP.

Completed oversight or inspection forms are provided in Attachment A.

2.2 System Start-Up Phase

Geosyntec coordinated with the Facility operators to schedule the system inspection and testing prior to startup on XXXX, 2022. Geosyntec inspected, tested and documented the system components in accordance with the Facility approved OAP as follows:

General Data

- Final construction inspections and complete permits have been signed off by the local jurisdiction (e.g. Building and Safety division),
- System general arrangement aligns with proposed plans including location and number of systems,
- System integrity and tightness testing has been completed where applicable,
- Validation that the proposed system methods, products and substances are being utilized (e.g. component branding, carbon filter types, and neutralizing agents),
- Facility weather station is functioning as designed,
- Operation and maintenance protocols and documentation processes are in place,
- Abatement system operator training and competency is complete,
- SCADA and/or PLC system has been commissioned, if applicable,
- System(s) functionality testing, and validation is complete (e.g. fail safes and alarms),

Flow Measurements

Air flows are a critical variable for adsorption and filtration systems. Operating at low flows below the design criteria may create conditions insufficient for adequate odor removal, and too high a flow may create conditions exceeding residence time or filtration capacities. Due to the variability of systems designs, Geosyntec has multiple approaches to validate design air flows using monitoring devices such as multifunction HVAC meters with and without shrouds, hot wire anemometers, and pitot tubes. One or multiple of these tools can be utilized to validate systems flows.

Similar to air flow, low flow rates and/or pressures in liquid-based odor-neutralizing compounds can create inefficiencies in droplet size and dispersion. Onsite evaluation of the output of liquid-based odor-neutralizing compounds will also have a variable approach depending on the facility. In the event the system does not utilize inline flow measuring devices, Geosyntec would likely make recommendations to the facility to

augment the system with flow meters or in-line rotameters to streamline future inspections. Should additional testing be necessary at the time of inspection, Geosyntec can deploy several approaches to measure in-line flows including portable ultrasonic mass flow meters, engineering analysis of pressures versus misting head design, and possible temporary in-line flow measurement tools.

System Efficiency

At the initiation of system operations, validation of system was determined using several approaches as follows:

- For the carbon adsorption systems within the warehouses the Nasal Ranger®, was used to measure the D/T values of air at the inlet and outlet of the treatment unit to determine the treatment efficiency is meeting the unit goals. A representative number of carbon units were selection for evaluation.
- For the Byers vapor phase system with Ecosorb CNB 107 used in the greenhouses, Nasal Range measurements were taken in the interior of the greenhouse and at the exterior of the greenhouse to confirm adequate odor control
- In addition, Nasal Ranger®, measurements were taken at the upwind and downwind perimeter of the facility to confirm adequate odor control

Attachment A presents the results of the inspection and monitoring of Facility system compliance.

Field measurements using the Nasal Ranger® can provide real-time information on the system operational status and if it is effectively controlling odors. Prior to using the Nasal Ranger®, Geosyntec personnel utilized an odor sensitivity test kit provided by St. Croix to test and prepare their olfactory sense.

Table 1 below shows the Nasal Ranger® field odor measurement locations and the field measurements results.

At each location where an odor reading is collected, the sampler inhaled into the Nasal Ranger®. The first measurement was collected at a D/T ratio of 60. The measurements were repeated at D/T ratios of 30, 15, 7, 4, and 2 until the odor was non-detectable. The D/T ratio below which the odor is non-detectable is the odor concentration in OU for that sample. The odor sampling locations were recorded on the Site plan. The odor sampling form in Attachment 1 documents the time of sampling, odor characteristics, concentration in OU, location, and meteorological conditions.

TABLE 1

Odor Source or Odor Sampling Location	Field Measurements with Nasal Ranger (D/T)	% Reduction in Odor Intensity
Facility Upwind		
Facility Downwind		
Warehouse 1		
Warehouse 2		
Carbon Unit 1 Influent		
Carbon Unit 1 Effluent		XX%
Carbon Unit 2 Influent		
Carbon Unit 2 Effluent		XX%
Carbon Unit 3 Influent		
Carbon Unit 3 Effluent		XX%
Greenhouse 1		
Greenhouse 2		
Greenhouse roof vent 1		XX%
Greenhouse roof vent 2		XX%

The results of this field screening indicated that some of the control systems were not operating efficiently and as a result odors and elevated D/T readings were observed around the facility. Additional testing was recommended to evaluate the odors using field gas chromatography methods and terpene analysis discussed in the following section.

2.3 Additional Monitoring When Odors Present

Because odors were observed and elevated D/T readings were recorded using the Nasal Ranger®, additional monitoring and analysis of terpenes was conducted. Samples were collected at two upwind and four downwind locations for a study duration of 24 to 48 hours and analyzed by the onsite field laboratory. With this scheme a sample location was sampled once each hour over the sample period. The results of the sampling was evaluated with respect to meteorological conditions over the time period to facilitate understanding of emissions over different parts of the day and different meteorological

conditions. This information was correlated with specific facility activities over the course of the samples period to identify if the odor is a result of a particular activity. Table 2 presents the results of the terpene analysis.

EXAMPLE

3. DISCUSSION AND CONCLUSIONS

This section discusses the findings of the inspection and monitoring conducted for the facility. Based on the results of the inspection Geosyntec provides a list of recommended actions to support the Cannabis operator to achieve compliance.

EXAMPLE

Attachment D-Example Completion Report



Prepared for:
**South Coast Air Quality Management District
Waste Management Permitting**
21865 Copley Drive
Diamond Bar, CA 91765

Prepared on behalf of:
Ascon Landfill Site Responsible Parties
14891 Yorba Street
Tustin, California 92780

COMPLETION REPORT

**Pit F Air Treatment System
Ascon Landfill Site
Huntington Beach, California**
SCAQMD Permits # G65607 and # G65610

Prepared by:



engineers | scientists | innovators

3530 Hyland Avenue, Suite 100
Costa Mesa, CA 92626

Project Number: HC1457

January 2022

TABLE OF CONTENTS

1.	INTRODUCTION	1-1
1.1	Overview and Purpose.....	1-1
1.2	Report Organization	1-2
2.	SYSTEM OPERATION	2-1
2.1	System Start-Up.....	2-1
2.2	System Operational Data	2-1
2.3	Activated Carbon Usage.....	2-2
3.	SYSTEM MONITORING.....	3-1
3.1	Sampling Procedures	3-1
3.2	SCAQMD Permit Compliance Monitoring.....	3-1
3.2.1	Condition #18 (H ₂ S Monitoring)	3-1
3.2.2	Condition #20 (PID Monitoring)	3-1
3.2.3	Condition #10 (Differential Pressure Monitoring).....	3-2
3.2.4	Conditions #21, #22, and #23 (Source Testing and Laboratory Analysis).....	3-2
4.	DISCUSSION AND CONCLUSIONS	4-1
4.1	Discussion.....	4-1
4.2	Conclusions	4-1

LIST OF TABLES

- Table 1:** Summary of Pit F Air Treatment System Performance and SCAQMD Compliance Monitoring Data (PID)
- Table 2:** Summary of Pit F Enclosure Differential Pressure Monitoring Data
- Table 3:** SCAQMD Compliance Monitoring Data – ATS Blower System 1 (Summarized Results of Third-Party Sampling and Laboratory Analyses)
- Table 4:** SCAQMD Compliance Monitoring Data – ATS Blower System 3 (Summarized Results of Third-Party Sampling and Laboratory Analyses)

LIST OF FIGURES

- Figure 1:** Vicinity and Site Location Maps
- Figure 2:** Ascon Landfill Site Layout
- Figure 3:** Pit F Enclosure Layout
- Figure 4:** Pit F Air Treatment System Process Flow Diagram

LIST OF APPENDICES

- Appendix A:** SCAQMD Permits
- Appendix B:** SCAQMD Compliance Test Reports – Alliance Source Testing

1. INTRODUCTION

This *Completion Report* (Report) presents parameters of the Pit F air treatment system (ATS or System) operations through the end of the 30-day start-up period (July 9th, 2021 through August 6th, 2021) at the Ascon Landfill Site, located at 21641 Magnolia Street in Huntington Beach, California (Site, Figure 1). Additional ATS testing and process information is also included for the period from August 6th through August 27th, 2021. This Report documents the operation, maintenance, and monitoring (OM&M) activities for the Pit F ATS and presents the source testing results for the System.

On behalf of Project Navigator, LLC (PNL), this document was prepared by Mr. Royston Chan and Mr. Christopher Lovett, and was reviewed by Mr. Keaton Botelho, each of Geosyntec Consultants, Inc. (Geosyntec) in accordance with the internal review policy of the firm. This Report was prepared in accordance with the guidelines presented in Condition #28 of the *South Coast Air Quality Management District (SCAQMD) Permit to Construct/Operate, Permit Number G65607, Application Number (A/N) 629232* and the *SCAQMD Permit to Construct/Operate, Permit Number G65610, A/N 629233*. The Permits were received from SCAQMD by PNL and Geosyntec on June 16th, 2021 (Appendix A).

1.1 Overview and Purpose

The Site is a vacant 38-acre parcel at the southwest corner of Hamilton Avenue and Magnolia Street in Huntington Beach, California (Figure 1). Nearby land uses include a community park, high school, residential areas, light industrial operations, oil storage, a flood control channel, and a power generating plant.

The Site operated as an active disposal facility from approximately 1938 to 1984. In the early years of operation, much of the waste came from oil drilling operations and included drilling muds, wastewater brines, and other drilling wastes. Records indicate that from 1957 to 1971, other wastes were also received by Site operators and deposited onsite. From 1971 to 1984, material deposited onsite included presumably non-hazardous solid wastes such as asphalt, concrete, metal, soil, and wood.

Currently, the Site contains four visible impoundments and one liner-covered pit. A layout of the Site is provided on Figure 2. Several former pits and lagoons were, over the course of approximately 30 years, filled in or covered by imported soil and construction debris. These areas currently appear as solid ground with scattered vegetative or gravel covering. All of the wastes received at the Site were placed on top of the original ground surface and were contained by berms. As the wastes accumulated, the berms were raised such that much of the Site is now 10 to 20 feet above surrounding street level.

The Final Remedial Action Plan was approved by Department of Toxic Substance (DTSC) in June 2015, and the Final Remedial Design was approved by DTSC in May 2017. The selected remedy for the Site includes partial excavation and removal of waste material in Pit F, consolidation of waste around the Site perimeter and City easement, and construction of an engineered cap over the reconsolidated waste. The Remedy Implementation Plan was submitted to DTSC on August 28th, 2018 (Geosyntec, 2018) and was conditionally approved on January 28th, 2019. Implementation of the Site remedy commenced in December 2018 with early mobilization activities, and with earthwork activities commencing in late January 2019.

During current Pit F excavation and waste removal activities, a tented enclosure around Pit F was used to contain emissions and direct them to the Pit F Air Treatment System (ATS), including Blower Systems 1 and 3, adjacent to the Pit F enclosure for treatment. A standby backup extraction blower was also located adjacent to Pit F (Blower System 2). The locations of the Pit F ATS and Pit F enclosure within the Site are provided on Figure 3, and the treatment process flow diagram is provided on Figure 4. An application for SCAQMD permits-to-operate (PTOs) was required by SCAQMD prior to implementation of the System. An application for the permits to construct/operate was submitted to SCAQMD on June 22nd, 2017 and the associated PTOs were received from SCAQMD on June 16th, 2021. The system start-up occurred on July 9th, 2021.

The Pit F air treatment system consists of the following, in order of process:

- Temporary Tensioned Fabric Structure Surrounding Pit F (Enclosure, Common to both PTOs);
- Two 10,000-pound granular activated carbon (GAC) filtration vessels per extraction blower to remove VOCs from the extracted vapor stream (total of six GAC vessels, two of which are backups);
- A total of three extraction blowers that have a maximum permitted flow rate of 5,000 scfm (one of which is a backup); and
- A total of three exhaust stacks to discharge treated air to the atmosphere (one of which is a backup).

Condition #28 of each PTO requires that specific monitoring data from the first 30 days of system operation be submitted to SCAQMD within 45 days of start-up to demonstrate compliance with Permit conditions. On September 17, 2021, a *Start-up Report* was submitted to SCAQMD to document compliance with the Permit conditions during start-up activities. The current report summarizes all Pit F ATS testing completed.

1.2 Report Organization

The remainder of this Report is organized into the following sections:

- Section 2, “*System Operation,*” in which the System operation activities for the start-up period are described and the data presented;
- Section 3, “*System Monitoring,*” in which the vapor monitoring data collected from various components are presented; and
- Section 4, “*Discussion and Conclusions.*”

2. SYSTEM OPERATION

2.1 System Start-Up

The Permits were received on June 16th, 2021. The System start-up period for the purpose of this report occurred from July 9th through August 6th, 2021. Source testing and laboratory analysis of collected air samples began during the first week of operation, on July 8th, 2021, prior to the excavation and closing the enclosure doors to meet the permit requirement for testing during the first week of operation. Additional data were collected in a second round of source testing when excavation started the week of June 12th, and a third round of source testing was done following the 30-day start-up period, from August 6th through 27th, 2021.

2.2 System Operational Data

To comply with the Permit conditions and evaluate System performance, the following data were collected: system flow rates, VOC concentrations at the inlet and outlet of each GAC vessel, H₂S concentrations at the outlet of each GAC vessel, temperature of the vapor stream at the inlet to each primary GAC vessel, and differential pressure readings for the Pit F enclosure. VOC concentrations were measured in the field with a hand-held photoionization detector (PID) in parts per million by volume (ppmv) as hexane. H₂S concentrations were measured in the field with a hand-held hydrogen sulfide analyzer, and differential pressure readings were measured in the field with a hand-held digital manometer. The data collected during testing demonstrate compliance with the Permit conditions as presented in Tables 1 and 2, and are further described below:

- Flow Rate: The average flow rate, as measured at the inlets to Blower System 1 and Blower System 3, was approximately 4,478 and 4,492 standard cubic feet per minute (scfm). The maximum permitted flow rate of 5,000 scfm per Condition #13 of the Permits was not exceeded.
- Inlet Stream Temperature: The average inlet stream temperature, as measured at the inlets to Blower System 1 and Blower System 3 was approximately 81 degrees Fahrenheit (°F) at both inlets. The maximum permitted inlet stream temperature of 145 °F per Condition #13 of the Permits was not exceeded.
- Influent VOC Concentrations: The maximum influent VOC concentration measured was approximately 130 ppmv and 121 ppmv as hexane, at the inlets to Blower System 1 and Blower System 3, respectively. The maximum permitted influent VOC concentration of 2,277 ppmv as hexane per Condition #19 of the Permits was not exceeded. In accordance with Condition #20, VOC concentrations were monitored daily.

- Outlet VOC Concentrations: The maximum outlet VOC concentration measured was approximately 12.2 and 5.7 ppmv as hexane, at the outlets of Blower System 1 and Blower System 3, respectively. The maximum permitted outlet VOC concentration of 22.77 ppmv as hexane per Condition #23 of the Permits was not exceeded. In accordance with Condition #20, VOC concentrations were monitored daily.
- Outlet H₂S Concentrations: H₂S was not detected at the outlets of either Blower System. The maximum permitted outlet VOC concentration of 0.25 ppmv per Condition #18 of the Permits was not exceeded.
- Pit F Enclosure Differential Pressure: The minimum differential pressure measured at the Pit F Enclosure was -0.02 inches of water column (in-WC) during remediation activities, through completion on August 24th. From August 25th to August 27th, the ATS was still operational and differential pressure measurements were taken, however the Enclosure doors were often open, which resulted in an occasional, temporary loss of negative pressure. In accordance with Condition #10, differential pressure was measured at a minimum of 4 times per 24-hour period and readings demonstrated the Pit F Enclosure was under negative pressure during remediation activities.

2.3 Activated Carbon Usage

No change-outs of the GAC used in either Blower Train of the System were required based on Permit conditions and observed field and laboratory VOC concentrations.

3. SYSTEM MONITORING

3.1 Sampling Procedures

Vapor samples were collected and analyzed by an independent, third-party laboratory, approved by SCAQMD per Rule 304, by the following sampling and analytical methods:

- Speciated VOCs by United States Environmental Protection Agency (USEPA) Method TO-15;
- Hydrogen Sulfide (H₂S) by SCAQMD Method 307-91;
- Total Hydrocarbons by USEPA Method TO-3;
- Bis(2-ethylhexyl)phthalate by USEPA Method TO-13A; and
- Polycyclic Aromatic Hydrocarbons (PAHs) by CARB Method 429

The laboratory samples were collected by Alliance Source Testing (Alliance), of Cypress, California. Samples were analyzed for Methods TO-3, TO-13A, and TO-15 by Eurofins TestAmerica located in Knoxville, Tennessee; 307-91 by Quantum Analytical Services, located in Carson, California; and CARB 429 by Vista Analytical, located in El Dorado Hills, California.

Total VOC monitoring was done using a portable PID, which was calibrated with 50 ppmv hexane calibration gas standard per EPA Method 21, in accordance with Condition #20 of the Permits.

3.2 SCAQMD Permit Compliance Monitoring

3.2.1 Condition #18 (H₂S Monitoring)

In accordance with Condition #18 of the Permits, the vapor at the outlet of the System was monitored using a hydrogen sulfide analyzer for H₂S. The results of the daily monitoring were in compliance with the Permit conditions (Table 1).

3.2.2 Condition #20 (PID Monitoring)

In accordance with Condition #20 of the Permits, the vapor at the inlet and outlet of each GAC adsorber was monitored daily using a portable PID following EPA Method 21 requirements. The results of the daily monitoring were in compliance with the Permit conditions (Table 1).

3.2.3 Condition #10 (Differential Pressure Monitoring)

In accordance with Condition #10 of the Permits, the differential pressure of the Pit F Enclosure was measured a minimum of four (4) times in each 24-hour period with a manometer. The results of the monitoring were in compliance with the Permit conditions (Table 2).

3.2.4 Conditions #21, #22, and #23 (Source Testing and Laboratory Analysis)

Condition #21 of the Permits requires that sampling and analysis be performed by an independent third-party firm per SCAQMD Rule 304. Permit Conditions #21 and #22 require that the firm collect one sample at the inlet and one sample at the outlet of the Pit F air treatment system during the first week of operation, during the first week of excavation, and at least monthly thereafter. Condition #23 lists specific analytes that the samples must be speciated for. Samples to satisfy the Permit conditions were collected by Alliance during the first week of operation, on July 8th, 9th, and 12th, 2021, and during the first week of excavation, on July 13th, 14th, and 15th, 2021. A final round of testing was done on August 10th, 11th, and 12th, 2021. Testing was done for speciated VOCs by USEPA Method TO-15, for total hydrocarbons by USEPA Method TO-3, for bis(2-ethylhexyl)phthalate by USEPA Method TO-13A, and for PAHs by CARB Method 429.

During source testing, Tedlar bag samples were also collected at the GAC outlets and analyzed for Total Sulfur Compounds, including H₂S, by SCAQMD Method 307-91. Summaries of the analytical laboratory results are presented in Tables 3 and 4. The Source Test Reports submitted by Alliance are presented in Appendix B, which is contained on a USB drive accompanying this report. The full laboratory analysis reports prepared by Eurofins TestAmerica are included in the Source Test Reports.

4. DISCUSSION AND CONCLUSIONS

4.1 Discussion

The test results for the first two weeks of sampling (July 8th-12th and July 13th-15th) show anomalous Perchloroethylene (PCE) concentrations detected in the inlet and outlet samples for both Blower Trains of the System. The test results for the third round of sampling (August 10th to 12th, 2021) showed that PCE concentrations were either nondetect or below permit limits.

The PCE results for the first two weeks of testing are considered anomalous because:

- PCE is not a primary chemical of concern in the waste that was excavated.
- Measured PCE levels were above permit limits on days when no excavation work was conducted (July 8th and July 9th), with the maximum PCE detection on July 8th. Activities that were occurring onsite on July 8th and 9th included health and safety briefings, Level B PPE Safety training and orientation, receipt of slurry excavation materials, and stockpiling of materials in the grout plant area. The remediation contractor also tested the process for ingress/egress of waste bins from the Pit F tent. The liner was removed on July 12th and excavation work began at that time.
- For several sample runs, the outlet PCE concentrations were higher than the inlet concentrations. This occurred on both Blower Systems tested (1 and 3), during both week 1 and week 2, indicating potential contamination issues.
- Testing data collected during monthly monitoring, required by Condition #28 of the Permits, indicated outlet concentrations that were either non-detect or below the permit limit of 0.7 ppb for PCE.
- During the third round of source testing, from August 10th to 12th, 2021, PCE results were either non-detect or below the permit limit at the inlet and outlet of both Blower Systems.

4.2 Conclusions

The following conclusions are made based on the data and observations during testing:

- Per the field and laboratory data collected, the System operated in compliance with the conditions of its SCAQMD Permits.

- The outlet sample results for the first two weeks of testing were below permit limits for all compounds except PCE. The sampling results of the third round of testing, from August 10th to 12th, indicated outlet concentrations below the relevant permit limits for all compounds.
- PCE results during weeks 1 and 2 of the start-up period were anomalous, for the reasons given above, and should not be considered indicative of normal System operation.

TABLES

TABLE 1
Summary of System Performance and SCAQMD Compliance Monitoring Data (PID)
Pit F Air Treatment System
Ascon Landfill Site
21641 Magnolia Street
Huntington Beach, California

Date / Time	Blower Train #1						Blower Train #3						Blower Train #2 (Back-up)					
	System Parameters		GAC Vessel VOC PID Readings			System Outlet H2S	System Parameters		GAC Vessel VOC PID Readings			System Outlet H2S	System Parameters		GAC Vessel VOC PID Readings			System Outlet H2S
	GAC Inlet Temp.	System Flow Rate	Vessel 1 Influent	Vessel 1 Effluent	Vessel 2 Effluent (Stack Outlet)		GAC Inlet Temp.	System Flow Rate	Vessel 1 Influent	Vessel 1 Effluent	Vessel 2 Effluent (Stack Outlet)		GAC Inlet Temp.	System Flow Rate	Vessel 1 Influent	Vessel 1 Effluent	Vessel 2 Effluent (Stack Outlet)	
	"F"	scfm	ppmv as hexane			ppmv	"F"	scfm	ppmv as hexane			ppmv	"F"	scfm	ppmv as hexane			ppmv
7/9/2021	79.2	4234	8.2	9.6	5.0	0.00	79	4469	12.4	5.8	4.9	0.00	N/A	N/A	N/A	N/A	N/A	N/A
7/10/2021	79.0	4275	1.2	6.2	1.1	0.00	82	4462	8.2	1.8	0.3	0.00	N/A	N/A	N/A	N/A	N/A	N/A
7/11/2021	80.1	4339	2.9	13.5	2.4	0.00	80	4485	5.8	3.6	1.5	0.00	N/A	N/A	N/A	N/A	N/A	N/A
7/12/2021	80.4	4190	1.2	2.7	2.6	0.00	81	4468	7.6	4.9	1.9	0.00	N/A	N/A	N/A	N/A	N/A	N/A
7/13/2021	84.1	4356	5.1	3.4	4.4	0.00	85	4471	4.4	2.0	1.9	0.00	N/A	N/A	N/A	N/A	N/A	N/A
7/14/2021	88.5	4262	10.5	2.3	3.1	0.00	90	4431	13.5	3.3	1.9	0.00	N/A	N/A	N/A	N/A	N/A	N/A
7/15/2021	84.7	4606	6.4	1.7	3.0	0.00	84	4404	5.7	1.6	1.8	0.00	N/A	N/A	N/A	N/A	N/A	N/A
7/16/2021	84.9	4591	5.6	1.2	5.0	0.00	81	4401	6.2	1.0	5.6	0.00	N/A	N/A	N/A	N/A	N/A	N/A
7/17/2021	78.8	4697	2.3	1.5	0.8	0.00	81	4420	7.1	1.4	0.4	0.00	N/A	N/A	N/A	N/A	N/A	N/A
7/18/2021	73.0	4675	0.9	0.5	0.4	0.00	73	4439	1.1	0.7	0.5	0.00	N/A	N/A	N/A	N/A	N/A	N/A
7/19/2021	85.5	4482	6.8	1.5	2.1	0.00	87	4369	10.6	1.3	1.1	0.00	N/A	N/A	N/A	N/A	N/A	N/A
7/20/2021	85.5	4488	1	0.3	0.3	0.00	85	4309	1.0	0.3	0.1	0.00	N/A	N/A	N/A	N/A	N/A	N/A
7/21/2021	88.8	4420	8.9	1.1	1.6	0.00	90	4360	11.1	1.4	0.6	0.00	N/A	N/A	N/A	N/A	N/A	N/A
7/22/2021	83.2	4467	10.1	1.3	2.3	0.00	84	4269	12.5	2.7	1.0	0.00	N/A	N/A	N/A	N/A	N/A	N/A
7/23/2021	81.8	4543	14.6	1.8	1.9	0.00	82	4345	16.7	3.0	1.3	0.00	N/A	N/A	N/A	N/A	N/A	N/A
7/24/2021	67.1	4535	2.9	1.2	0.9	0.00	67	4345	3.6	1.4	1.2	0.00	N/A	N/A	N/A	N/A	N/A	N/A
7/25/2021	66.4	4552	3.3	1.9	1.3	0.00	67	4349	3.4	1.5	1.2	0.00	N/A	N/A	N/A	N/A	N/A	N/A
7/26/2021	93.5	4467	56.4	1.8	3.3	0.00	95	4244	62.1	4.6	1.4	0.00	N/A	N/A	N/A	N/A	N/A	N/A
7/27/2021	83.7	4507	69.2	1.7	1.5	0.00	84	4268	71.0	8.9	2.5	0.00	N/A	N/A	N/A	N/A	N/A	N/A
7/28/2021	86.8	4473	53.4	4.8	1.6	0.00	88	4253	57.6	4.3	1.5	0.00	N/A	N/A	N/A	N/A	N/A	N/A
7/29/2021	88.5	4469	71.9	7.4	1.9	0.00	89	4301	68.9	7.6	1.6	0.00	N/A	N/A	N/A	N/A	N/A	N/A
7/30/2021	85.7	4693	26.4	3.6	0.1	0.00	85	4775	23.9	2.7	0.0	0.00	N/A	N/A	N/A	N/A	N/A	N/A
7/31/2021	74.3	4775	6.2	1.4	1.2	0.00	73	4780	9.6	1.7	1.0	0.00	N/A	N/A	N/A	N/A	N/A	N/A
8/1/2021	74.1	4716	3.6	1.5	3.6	0.00	74	4810	5.4	2.2	1.1	0.00	N/A	N/A	N/A	N/A	N/A	N/A
8/2/2021	79.5	4683	32.9	2.0	3.2	0.00	81	4735	22.9	0.9	0.9	0.00	N/A	N/A	N/A	N/A	N/A	N/A
8/3/2021	75.7	4672	18.9	1.6	1.9	0.00	77	4730	14.6	1.3	1.2	0.00	N/A	N/A	N/A	N/A	N/A	N/A
8/4/2021	86.7	4671	17.0	2.0	1.2	0.00	87	4744	23.4	2.2	2.2	0.00	N/A	N/A	N/A	N/A	N/A	N/A
8/5/2021	90.2	4718	34.0	1.2	0.8	0.00	86	4783	29.3	1.3	1.3	0.00	N/A	N/A	N/A	N/A	N/A	N/A
8/6/2021	85.1	4704	13.1	0.9	0.5	0.00	81	4770	14.0	1.9	0.9	0.00	N/A	N/A	N/A	N/A	N/A	N/A
8/7/2021	76.0	4747	4.1	0.6	0.2	0.0	76.1	4670	4.0	0.5	0.4	0.00	N/A	N/A	N/A	N/A	N/A	N/A
8/8/2021	73.9	4666	2.4	0.0	0.0	0.0	72.9	4759	3.9	0.0	0.0	0.00	N/A	N/A	N/A	N/A	N/A	N/A
8/9/2021	85.2	4562	66.9	4.4	1.7	0.0	86.0	4688	42.9	2.0	0.9	0.00	N/A	N/A	N/A	N/A	N/A	N/A
8/10/2021	83.3	4458	87.6	4.2	5.3	0.0	88.2	4632	97.2	5.4	5.7	0.00	N/A	N/A	N/A	N/A	N/A	N/A
8/11/2021	81.7	4638	52.5	4.3	1.6	0.0	81.1	4562	54.1	6.4	2.1	0.00	N/A	N/A	N/A	N/A	N/A	N/A
8/12/2021	89.6	4634	66.3	3.2	4.3	0.0	90.4	4541	53.2	5.1	5.2	0.00	N/A	N/A	N/A	N/A	N/A	N/A
8/13/2021	83.1	4498	33.6	1.6	0.7	0.0	83.1	4601	26.2	1.5	1.0	0.00	N/A	N/A	N/A	N/A	N/A	N/A
8/14/2021	73.8	4532	4.5	0.9	0.4	0.0	71.2	4648	4.8	0.5	0.1	0.00	N/A	N/A	N/A	N/A	N/A	N/A
8/15/2021	68.1	4502	3.0	0.7	0.6	0.0	69.5	4704	3.3	0.8	0.6	0.00	N/A	N/A	N/A	N/A	N/A	N/A
8/16/2021	85.40	4389.00	82.6	6.0	5.5	0.0	87.88	4488.00	78.2	7.1	5.3	0.00	N/A	N/A	N/A	N/A	N/A	N/A
8/17/2021	93.50	4458.00	78.0	1.8	0.8	0.0	89.37	4352.00	73.4	2.2	1.5	0.00	N/A	N/A	N/A	N/A	N/A	N/A
8/18/2021	79.38	4348.00	50.3	1.9	1.7	0.0	80.31	4448.00	53.9	1.2	0.5	0.00	N/A	N/A	N/A	N/A	N/A	N/A
8/19/2021	89.99	4363.00	73.2	2.1	1.1	0.0	87.83	4526.00	67.2	1.1	0.2	0.00	N/A	N/A	N/A	N/A	N/A	N/A
8/20/2021	81.07	4324.00	108.7	1.4	1.7	0.0	84.32	4429.00	111.3	1.1	0.1	0.00	N/A	N/A	N/A	N/A	N/A	N/A
8/21/2021	77.58	4354.00	13.9	2.0	0.4	0.0	77.85	4493.00	14.2	2.4	1.0	0.00	N/A	N/A	N/A	N/A	N/A	N/A
8/22/2021	77.70	4382.24	7.3	0.9	0.1	0.0	76.91	4464.00	9.1	1.8	0.4	0.00	N/A	N/A	N/A	N/A	N/A	N/A
8/23/2021	78.24	4262.00	129.8	2.2	12.2	0.0	80.82	4393.00	120.5	2.5	3.2	0.00	N/A	N/A	N/A	N/A	N/A	N/A
8/24/2021	81.58	4267.00	23.6	1.8	0.0	0.0	80.49	4360.00	27.0	0.9	0.0	0.00	N/A	N/A	N/A	N/A	N/A	N/A
8/25/2021	67.47	4252.00	1.6	0.6	0.6	0.0	71.23	4469.00	1.4	0.6	0.2	0.00	N/A	N/A	N/A	N/A	N/A	N/A
8/26/2021	61.15	4007.00	1.5	1.1	0.6	0.0	61.70	4192.00	2.0	1.4	1.1	0.00	N/A	N/A	N/A	N/A	N/A	N/A
8/27/2021	63.40	4017.00	1.2	1.0	0.4	0.0	64.50	4210.00	1.8	0.9	0.4	0.00	N/A	N/A	N/A	N/A	N/A	N/A
	80.5	4478.4	129.8	13.5	12.2		80.8	4492.4	120.5	8.9	5.7							

Abbreviations: N/A - Not applicable or not being used; VOC - volatile organic compounds; PID - photoionization detector; GAC - granular activated carbon; SCAQMD - South Coast Air Quality Management District; scfm - standard cubic feet per minute; - degrees

Fahrenheit; ppmv - parts per million by volume

Notes:

1) First day of operation was July 9, 2021.

2) Vessel 1 Effluent port on Blower Train #1 discovered to be contaminated on the first monitoring event on July 9th due to PID VOC readings being significantly higher at the Vessel 1 Effluent port than the Vessel 1 Influent port. The Vessel 1 Effluent port was replaced after the monitoring event on July 12th.

TABLE 2
Summary of Differential Pressure Monitoring Data
Pit F Enclosure
Ascon Landfill Site
21641 Magnolia Street
Huntington Beach, California

Date	Time	Differential Pressure (in-WC)	Date	Time	Differential Pressure (in-WC)	Date	Time	Differential Pressure (in-WC)
7/9/2021	0745	-0.03	7/19/2021	1645	-0.06	7/30/2021	1015	-0.04
7/9/2021	1130	-0.03	7/20/2021	0740	-0.05	7/30/2021	1300	-0.03
7/9/2021	1645	-0.04	7/20/2021	1040	-0.02	7/30/2021	1500	-0.12
7/9/2021	1730	-0.05	7/20/2021	1415	-0.04	7/31/2021	1000	-0.11
7/10/2021	1400	-0.03	7/20/2021	1600	-0.04	7/31/2021	1030	-0.10
7/10/2021	1430	-0.03	7/21/2021	0800	-0.03	7/31/2021	1100	-0.10
7/10/2021	1500	-0.03	7/21/2021	0945	-0.04	7/31/2021	1135	-0.15
7/10/2021	1530	-0.03	7/21/2021	1145	-0.04	8/1/2021	1735	-0.09
7/11/2021	1200	-0.03	7/21/2021	1625	-0.07	8/1/2021	1805	-0.11
7/11/2021	1230	-0.03	7/22/2021	0750	-0.03	8/1/2021	1835	-0.10
7/11/2021	1300	-0.02	7/22/2021	0920	-0.03	8/1/2021	1905	-0.10
7/11/2021	1330	-0.02	7/22/2021	1255	-0.04	8/2/2021	0735	-0.04
7/12/2021	0855	-0.03	7/22/2021	1405	-0.02	8/2/2021	1025	-0.03
7/12/2021	1315	-0.03	7/23/2021	0800	-0.04	8/2/2021	1230	-0.05
7/12/2021	1400	-0.03	7/23/2021	1105	-0.03	8/2/2021	1620	-0.09
7/12/2021	1635	-0.03	7/23/2021	1300	-0.04	8/3/2021	0725	-0.08
7/13/2021	0900	-0.04	7/23/2021	1510	-0.03	8/3/2021	1145	-0.09
7/13/2021	1110	-0.03	7/23/2021	1525	-0.04	8/3/2021	1240	-0.11
7/13/2021	1430	-0.03	7/24/2021	0709	-0.03	8/3/2021	1640	-0.11
7/13/2021	1535	-0.04	7/24/2021	0740	-0.05	8/4/2021	0755	-0.08
7/14/2021	0810	-0.02	7/24/2021	0810	-0.03	8/4/2021	1053	-0.11
7/14/2021	1140	-0.03	7/24/2021	0840	-0.03	8/4/2021	1305	-0.09
7/14/2021	1400	-0.02	7/25/2021	0700	-0.02	8/4/2021	1400	-0.08
7/14/2021	1640	-0.03	7/25/2021	0730	-0.03	8/5/2021	0735	-0.09
7/15/2021	0830	-0.03	7/25/2021	0800	-0.03	8/5/2021	1000	-0.06
7/15/2021	1135	-0.03	7/25/2021	0830	-0.02	8/5/2021	1300	-0.11
7/15/2021	1330	-0.03	7/26/2021	0900	-0.03	8/5/2021	1400	-0.11
7/15/2021	1620	-0.03	7/26/2021	1130	-0.06	8/6/2021	0810	-0.03
7/16/2021	0735	-0.03	7/26/2021	1250	-0.04	8/6/2021	0937	-0.11
7/16/2021	1150	-0.05	7/26/2021	1420	-0.05	8/6/2021	1349	-0.08
7/16/2021	1300	-0.07	7/27/2021	0740	-0.04	8/6/2021	1511	-0.07
7/16/2021	1625	-0.08	7/27/2021	1240	-0.12	8/9/2021	0815	-0.07
7/17/2021	0900	-0.03	7/27/2021	1430	-0.05	8/9/2021	1045	-0.08
7/17/2021	0930	-0.04	7/27/2021	1600	-0.07	8/9/2021	1323	-0.07
7/17/2021	1015	-0.04	7/28/2021	0755	-0.05	8/9/2021	1345	-0.05
7/17/2021	1100	-0.03	7/28/2021	1000	-0.09	8/10/2021	740	-0.08
7/18/2021	0845	-0.04	7/28/2021	1300	-0.09	8/10/2021	1230	-0.07
7/18/2021	0900	-0.04	7/28/2021	1545	-0.10	8/10/2021	1330	-0.07
7/18/2021	0915	-0.03	7/29/2021	0734	-0.06	8/10/2021	1440	-0.12
7/18/2021	0945	-0.04	7/29/2021	1000	-0.12	8/11/2021	750	-0.09
7/19/2021	0830	-0.02	7/29/2021	1325	-0.10	8/11/2021	940	-0.10
7/19/2021	0851	-0.02	7/29/2021	1545	-0.09	8/11/2021	1330	-0.11
7/19/2021	1450	-0.11	7/30/2021	0730	-0.06	8/11/2021	1500	-0.11

Notes:

in-WC - inches of water column

TABLE 2
 Summary of Differential Pressure Monitoring Data
 Pit F Enclosure
 Ascon Landfill Site
 21641 Magnolia Street
 Huntington Beach, California

Date	Time	Differential Pressure (in-WC)	Date	Time	Differential Pressure (in-WC)	Date	Time	Differential Pressure (in-WC)
8/12/2021	0935	-0.07	8/18/2021	0745	-0.08	8/25/2021	0840	0.00 (operation complete, tent doors open)
8/12/2021	1050	-0.09	8/18/2021	1100	-0.07	8/25/2021	1015	
8/12/2021	1200	-0.08	8/18/2021	1215	-0.07	8/25/2021	1245	
8/12/2021	1500	-0.09	8/18/2021	1400	-0.07	8/25/2021	1600	
8/13/2021	0915	-0.03	8/19/2021	930	-0.08	8/26/2021	645	-0.04
8/13/2021	1045	-0.09	8/19/2021	1210	-0.08	8/26/2021	1000	-0.03
8/13/2021	1300	-0.05	8/19/2021	1245	-0.07	8/26/2021	1100	0.00 (doors open)
8/13/2021	1500	-0.09	8/19/2021	1315	-0.07	8/26/2021	1330	-0.03
8/14/2021	0825	-0.08	8/20/2021	900	-0.08	8/27/2021	700	-0.07
8/14/2021	0840	-0.08	8/20/2021	1030	-0.08	8/27/2021	1000	0.00 (doors open)
8/14/2021	0900	-0.09	8/20/2021	1315	-0.08	8/27/2021	1200	0.00 (doors open)
8/14/2021	0920	-0.09	8/20/2021	1500	-0.09			
8/15/2021	0745	-0.08	8/21/2021	1125	-0.09			
8/15/2021	0800	-0.08	8/21/2021	1225	-0.09			
8/15/2021	0815	-0.08	8/22/2021	1100	-0.13			
8/15/2021	0845	-0.07	8/22/2021	1130	-0.12			
8/16/2021	0740	-0.06	8/23/2021	800	-0.09			
8/16/2021	1025	-0.08	8/23/2021	1030	-0.08			
8/16/2021	1245	-0.05	8/23/2021	1215	-0.07			
8/16/2021	1420	-0.06	8/23/2021	1530	-0.1			
8/17/2021	0915	-0.06	8/24/2021	750	-0.06			
8/17/2021	1015	-0.07	8/24/2021	1030	-0.07			
8/17/2021	1230	-0.07	8/24/2021	1240	-0.07			
8/17/2021	1415	-0.05	8/24/2021	1430	-0.07			

Notes:

in-WC - inches of water column

TABLE 3
 SCAQMD Compliance Monitoring Data
 Summary of Carbon System 1 Results
 Pit F Air Treatment System
 Ascon Landfill Site
 21641 Magnolia Street
 Huntington Beach, California



PARAMETER	Test Method	UNIT	WEEK 1								WEEK 2								OUTLET PERMIT LIMIT
			INLET				OUTLET				INLET				OUTLET				
			Average	July 8th	July 9th	July 12th	Average	July 8th	July 9th	July 12th	Average	July 13th	July 14th	July 15th	Average	July 13th	July 14th	July 15th	
Benz[a]anthracene	CARB 429	ppb	<3.5E-05	<3.7E-05	<3.4E-05	<3.5E-05	<1.9E-05	<2.0E-05	<1.9E-05	<1.9E-05	<3.7E-05	<3.6E-05	<3.7E-05	<3.7E-05	<2.0E-05	<2.0E-05	<2.0E-05	<2.0E-05	0.4
Benzo[b]fluoranthene	CARB 429	ppb	<3.2E-05	<3.3E-05	<3.1E-05	<3.1E-05	<1.8E-05	<1.8E-05	<1.7E-05	<1.7E-05	<3.3E-05	<3.2E-05	<3.4E-05	<3.4E-05	<1.8E-05	<1.8E-05	<1.8E-05	<1.8E-05	0.4
Chrysene	CARB 429	ppb	<3.5E-05	<3.7E-05	<3.4E-05	<3.5E-05	<1.9E-05	<2.0E-05	<1.9E-05	<1.9E-05	<3.7E-05	<3.6E-05	<3.7E-05	<3.7E-05	<2.0E-05	<2.0E-05	<2.0E-05	<2.0E-05	0.35
Dibenz[a,h]anthracene	CARB 429	ppb	<2.9E-05	<3.0E-05	<2.8E-05	<2.8E-05	<1.6E-05	<1.7E-05	<1.6E-05	<1.6E-05	<3.0E-05	<2.9E-05	<3.1E-05	<3.0E-05	<1.6E-05	<1.6E-05	<1.7E-05	<1.6E-05	0.35
Naphthalene	CARB 429	ppb	5.2E-02	9.0E-03	9.3E-03	1.4E-01	4.9E-04	5.1E-04	5.4E-04	4.2E-04	3.5E+00	2.6E+00	3.9E+00	3.8E+00	5.3E-04	6.1E-04	4.2E-04	5.6E-04	25
Bis(2-ethylhexyl)phthalate	TO-13A	ppb	0.1	0.18	0.061	0.062	0.12	<0.11	<0.11	0.14	<0.10	<0.11	<0.10	<0.10	<1.1E-01	<1.1E-01	<1.1E-01	<1.1E-01	4
TOC as Hexane	TO-3	ppm	0.093	0.053	0.16	0.069	1.47	1.75	2.52	0.15	0.95	0.83	1.15	0.86	0.081	0.027	0.028	0.19	22.77
Ethylbenzene	TO-15	ppb	1.56	1.82	1.58	1.28	1.76	1.74	1.61	1.93	12.27	2.81	19	15	0.69	1.04	0.497	0.524	5
Benzene	TO-15	ppb	0.721	1.29	0.469	0.404	0.855	1.56	0.535	0.469	0.624	0.474	0.919	0.479	0.228	<0.363	0.132	0.189	25
1,2-Dichloroethane	TO-15	ppb	<0.444	<0.5	<0.333	<0.5	<0.050	<0.5	<0.5	<0.5	<1.9E-01	<0.25	<0.25	<0.0725	<2.3E-01	<0.453	<0.0833	<0.167	0.4
Tetrachloroethylene (PCE)	TO-15	ppb	8.48	12.4	4.99	8.06	9.7	8.2	10.6	10.3	<0.134	<0.175	<0.175	<0.0508	3.17	5.41	2.05	2.04	0.7
Trichloroethylene	TO-15	ppb	<0.578	<0.65	<0.433	<0.65	<0.65	<0.65	<0.65	<0.65	<0.248	<0.325	<0.325	<0.0943	<0.305	<0.589	<0.108	<0.217	0.8
Acrylonitrile	TO-15	ppb	<6.69	<11	<3.63	<5.45	<5.45	<5.45	<5.45	<5.45	<2.08	<2.73	<2.73	<0.790	<2.56	<4.94	<0.908	<1.82	4

PARAMETER	Test Method	UNIT	WEEK 3								OUTLET PERMIT LIMIT
			INLET				OUTLET				
			Average	Aug 10th	Aug 11th	Aug 12th	Average	Aug 10th	Aug 11th	Aug 12th	
Benz[a]anthracene	CARB 429	ppb	<2.0E-05	<2.0E-05	<1.9E-05	<1.9E-05	<2.0E-05	<2.0E-05	<2.0E-05	<2.0E-05	0.4
Benzo[b]fluoranthene	CARB 429	ppb	<2.3E-05	<1.8E-05	<2.6E-05	<2.7E-05	<1.8E-05	<1.8E-05	<1.8E-05	<1.8E-05	0.4
Chrysene	CARB 429	ppb	<5.4E-05	<2.6E-05	<6.7E-05	<6.9E-05	<2.0E-05	<2.0E-05	<2.0E-05	<2.0E-05	0.35
Dibenz[a,h]anthracene	CARB 429	ppb	<1.6E-05	<1.6E-05	<1.6E-05	<1.6E-05	<1.7E-05	<1.7E-05	<1.7E-05	<1.7E-05	0.35
Naphthalene	CARB 429	ppb	4.7	5.9	3.9	4.4	3.3E-03	3.2E-03	3.0E-03	3.8E-03	25
Bis(2-ethylhexyl)phthalate	TO-13A	ppb	0.11	0.11	0.11	0.11	0.10	0.11	0.10	0.10	4
TOC as Hexane	TO-3	ppm	3.9	4.9	6.1	0.82	0.079	0.11	0.076	0.056	22.77
Ethylbenzene	TO-15	ppb	962	1,850	973	64.3	<0.13	<0.130	<0.127	<0.130	5
Benzene	TO-15	ppb	141	260	157	6.52	<0.179	<0.336	<0.120	<0.0800	25
1,2-Dichloroethane	TO-15	ppb	<2.0	<4.34	<1.61	<0.0386	<0.099	<0.100	<0.0975	<0.100	0.4
Tetrachloroethylene (PCE)	TO-15	ppb	<1.40	<3.04	<1.13	<0.0268	<0.069	<0.070	<0.0683	<0.070	0.7
Trichloroethylene	TO-15	ppb	<2.592	<5.64	<2.10	<0.0361	<0.139	<0.130	<0.127	<0.160	0.8
Acrylonitrile	TO-15	ppb	<21.73	<47.3	<17.6	<0.303	<1.08	<1.09	<1.06	<1.09	4

Notes:
 Data presented herein represents the average of three runs as reported by Alliance Source Testing.
 < X = Not detected above the detection limit; the method detection limit was used for calculations.
 ppb = parts per billion by volume
 Total Sulfur as H2S all nondetect

TABLE 4
 SCAQMD Compliance Monitoring Data
 Summary of Carbon System 3 Results
 Pit F Air Treatment System
 Ascon Landfill Site
 21641 Magnolia Street
 Huntington Beach, California



PARAMETER	Test Method	UNIT	WEEK 1								WEEK 2								OUTLET PERMIT LIMIT
			INLET				OUTLET				INLET				OUTLET				
			Average	July 8th	July 9th	July 12th	Average	July 8th	July 9th	July 12th	Average	July 13th	July 14th	July 15th	Average	July 13th	July 14th	July 15th	
Benz[a]anthracene	CARB 429	ppb	<4.5E-05	<4.7E-05	<4.5E-05	<4.3E-05	<2.0E-05	<2.0E-05	<2.0E-05	<2.0E-05	<4.5E-05	<4.5E-05	<4.5E-05	<4.6E-05	<1.8E-05	<1.9E-05	<1.7E-05	<1.7E-05	0.4
Benzo[b]fluoranthene	CARB 429	ppb	<4.1E-05	<4.2E-05	<4.1E-05	<3.9E-05	<1.8E-05	<1.8E-05	<1.8E-05	<1.8E-05	<4.1E-05	<4.0E-05	<4.0E-05	<4.2E-05	<1.6E-05	<1.8E-05	<1.6E-05	<1.6E-05	0.4
Chrysene	CARB 429	ppb	<4.5E-05	<4.7E-05	<4.5E-05	<4.3E-05	<2.0E-05	<2.0E-05	<2.0E-05	<2.0E-05	<4.5E-05	<4.5E-05	<4.5E-05	<4.6E-05	<1.8E-05	<1.9E-05	<1.7E-05	<1.7E-05	0.35
Dibenz[a,h]anthracene	CARB 429	ppb	<3.7E-05	<3.8E-05	<3.7E-05	<3.5E-05	<1.6E-05	<1.6E-05	<1.6E-05	<1.6E-05	<3.7E-05	<3.7E-05	<3.7E-05	<3.8E-05	<1.5E-05	<1.6E-05	<1.4E-05	<1.4E-05	0.35
Naphthalene	CARB 429	ppb	8.3E-02	1.2E-02	9.4E-03	2.3E-01	5.5E-04	7.4E-04	4.3E-04	4.9E-04	5.1E+00	3.8E+00	4.6E+00	6.9E+00	5.1E-04	6.1E-04	5.3E-04	3.9E-04	25
Bis(2-ethylhexyl)phthalate	TO-13A	ppb	1.6E-01	<0.10	<0.10	2.8E-01	0.30	0.16	<0.10	0.63	<0.10	<0.10	<0.10	<0.10	<0.11	<0.10	<0.10	<0.10	4
TOC as Hexane	TO-3	ppm	0.073	0.093	0.051	0.074	0.056	0.019	0.13	0.019	0.27	0.17	0.39	0.25	0.041	0.028	0.019	0.076	22.77
Ethylbenzene	TO-15	ppb	2.51	1.43	5.45	0.649	1.47	4.08	0.172	0.168	9.24	1.93	16.3	9.48	0.0817	0.178	0.0469	0.0203	5
Benzene	TO-15	ppb	0.61	1.03	0.544	0.254	0.56	<1.36	0.144	0.179	0.47	0.307	0.606	0.486	0.0692	0.0813	0.0895	0.0367	25
1,2-Dichloroethane	TO-15	ppb	<0.435	<0.815	<0.428	<0.0625	<5.8E-01	<1.70	<0.0219	<0.01	<2.5E-01	<0.19	<0.42	<0.132	0.0152	<0.0175	0.0179	0.0102	0.4
Tetrachloroethylene (PCE)	TO-15	ppb	5.46	6.82	9.42	0.135	9.15	27.1	0.321	0.0437	<0.173	<0.133	<0.294	<0.0923	0.135	0.288	0.0963	0.0207	0.7
Trichloroethylene	TO-15	ppb	<0.566	<1.06	<0.556	<0.0813	0.788	<2.21	0.113	0.0412	<0.321	<0.247	<0.546	<0.171	0.0289	0.0573	<0.0163	<0.013	0.8
Acrylonitrile	TO-15	ppb	<4.83	<8.88	<4.66	<0.938	<6.28	<18.5	<0.238	<0.109	<2.7	<2.07	<4.58	<1.44	<0.145	<0.191	<0.136	<0.109	4

PARAMETER	Test Method	UNIT	WEEK 3								OUTLET PERMIT LIMIT
			INLET				OUTLET				
			Average	Aug 10th	Aug 11th	Aug 12th	Average	Aug 10th	Aug 11th	Aug 12th	
Benz[a]anthracene	CARB 429	ppb	<2.3E-05	<2.3E-05	<2.4E-05	<2.4E-05	<2.1E-05	<2.1E-05	<2.1E-05	<2.1E-05	0.4
Benzo[b]fluoranthene	CARB 429	ppb	<2.1E-05	<2.1E-05	<2.1E-05	<2.1E-05	<1.9E-05	<1.9E-05	<1.9E-05	<1.9E-05	0.4
Chrysene	CARB 429	ppb	<3.7E-05	<2.7E-05	<4.2E-05	<4.3E-05	<2.1E-05	<2.1E-05	<2.1E-05	<2.1E-05	0.35
Dibenz[a,h]anthracene	CARB 429	ppb	<1.9E-05	<1.9E-05	<1.9E-05	<1.9E-05	<1.8E-05	<1.7E-05	<1.7E-05	<1.8E-05	0.35
Naphthalene	CARB 429	ppb	4.2	7.5	3.3	2.0	4.5E-03	5.0E-03	5.2E-03	3.3E-03	25
Bis(2-ethylhexyl)phthalate	TO-13A	ppb	0.11	0.11	0.12	0.11	0.11	0.11	0.12	0.11	4
TOC as Hexane	TO-3	ppm	7.8	9.3	11.4	2.7	0.47	1.1	0.19	0.058	22.77
Ethylbenzene	TO-15	ppb	1,382	1,830	735	1,580	1.00	2.49	<0.436	<0.0871	5
Benzene	TO-15	ppb	<180	<197	118	224	<0.338	0.752	<0.178	<0.0842	25
1,2-Dichloroethane	TO-15	ppb	<1.221	<0.673	<2.13	<0.860	<0.082	<0.0500	<0.128	<0.0670	0.4
Tetrachloroethylene (PCE)	TO-15	ppb	<0.85	<0.471	<1.49	<0.602	0.39	0.421	<0.405	<0.358	0.7
Trichloroethylene	TO-15	ppb	<1.585	<0.875	<2.76	<1.12	<0.106	<0.0650	<0.167	<0.0871	0.8
Acrylonitrile	TO-15	ppb	<13.29	<7.33	<23.2	<9.34	<0.89	<0.545	<1.40	<0.730	4

Notes:
 Data presented herein represents the average of three runs as reported by Alliance Source Testing.
 <X = Not detected above the detection limit; the method detection limit was used for calculations.
 ppb = parts per billion by volume
 Total Sulfur as H2S all nondetect

FIGURES

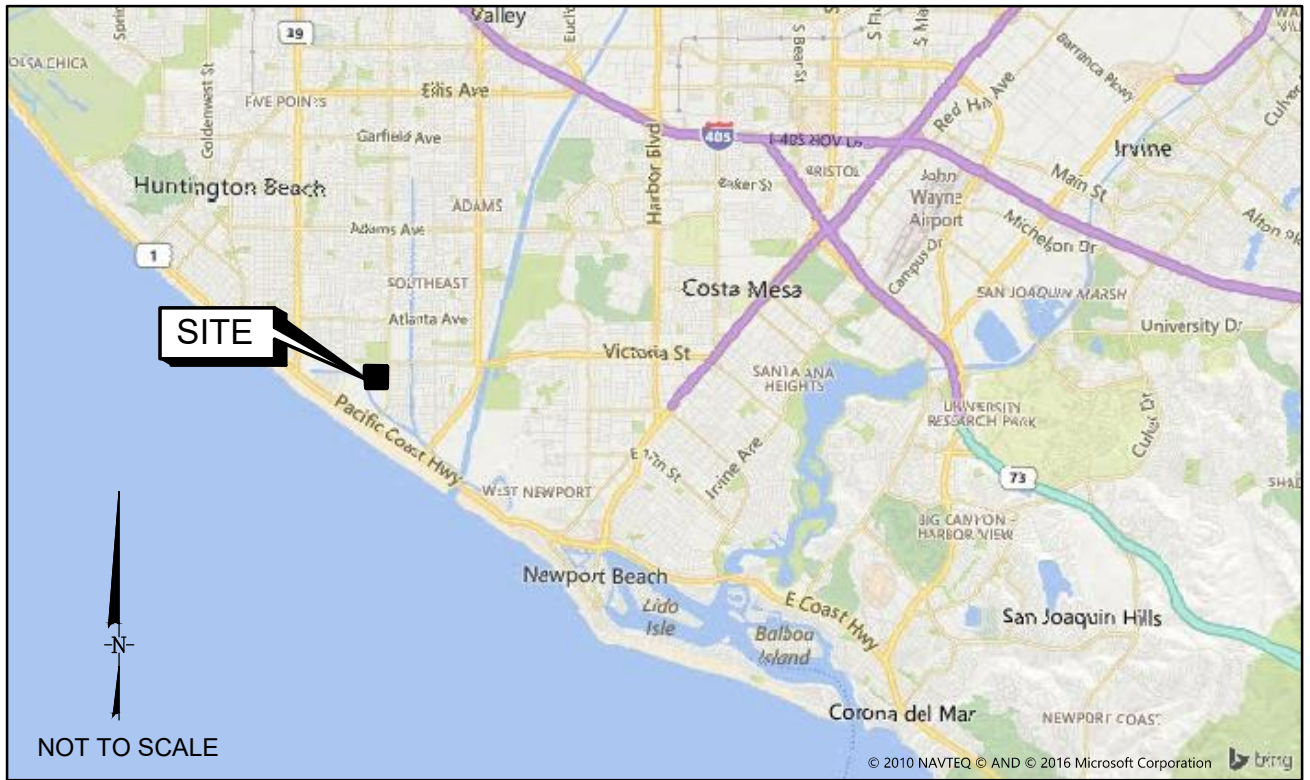

VICINITY MAP

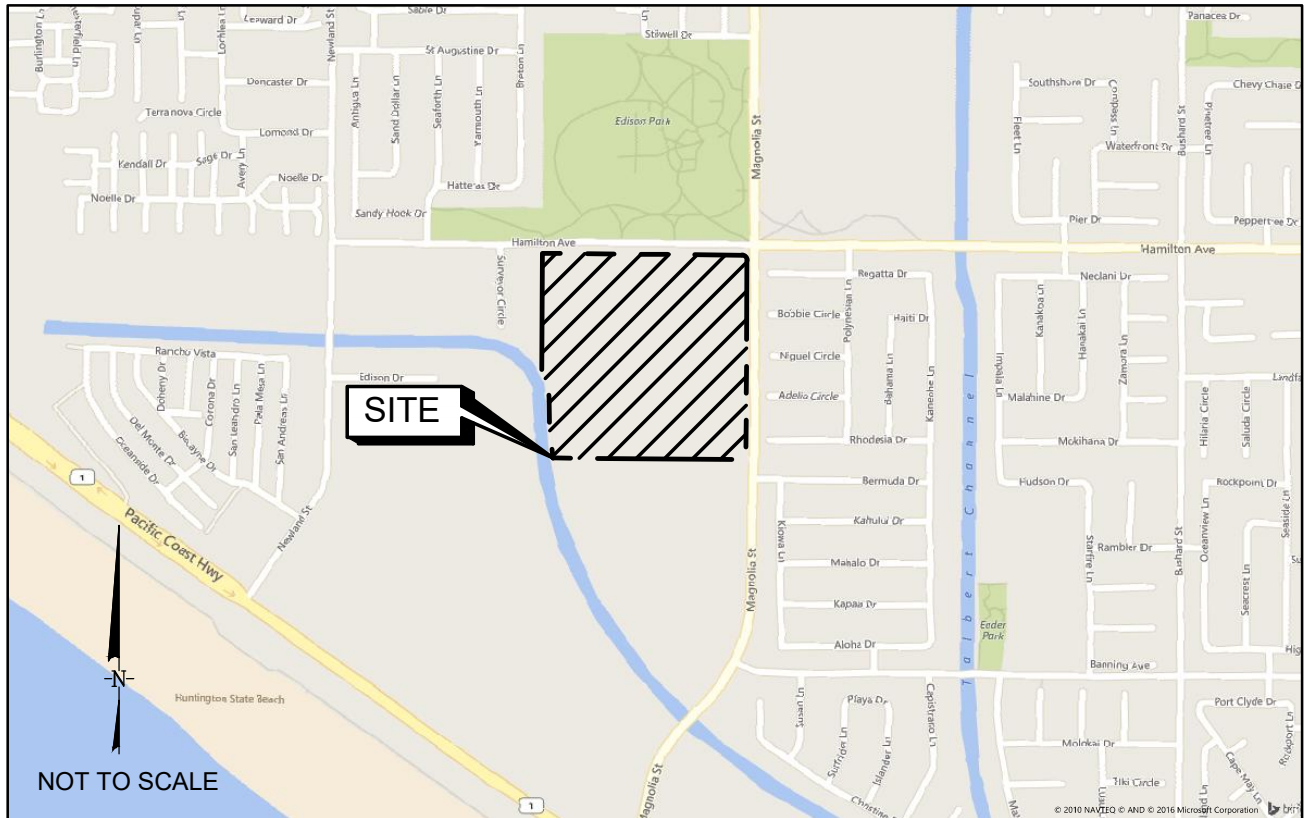

SITE LOCATION MAP

SITE VICINITY AND LOCATION MAP
 ASCON LANDFILL SITE
 HUNTINGTON BEACH, CALIFORNIA



DATE: AUGUST 2021
 PROJECT NO. HC1457

FIGURE
 1

P:\PRJ\SDCadd\CADD\HC1457 Ascon Landfill\HC1457A-08\Figures\HC1457B FIGURE 02.dwg



LEGEND

- 20 EXISTING GROUND MAJOR CONTOUR (5')
- EXISTING GROUND MINOR CONTOUR (1')
- PROPERTY LINE
- LIMITS OF GRADING
- LAGOON BOUNDARY
- EXISTING OIL WELLS (COORDINATES TO BE PROVIDED)
- W.L. 6.8 WATER LEVEL AT 6.8 FEET M.S.L. ON 3/30/2011

NOTE

1. EXISTING GROUND TOPOGRAPHY AND SITE FEATURES ARE BASED ON AN AERIAL SURVEY CONDUCTED ON MARCH 30, 2011 BY COOPER AERIAL SURVEYS CO.

- CITY OF HUNTINGTON BEACH PARCEL
- PACIFIC RANCH WELLS 1 AND 1A
- LIMITS OF GRADING
- KRIK WELL 80
- EXISTING TRAILER
- APPROXIMATE LOCATION OF WATER SUPPLY
- SITE ENTRANCE
- DEEBLE WELL NO. 1
- SITE EXIT
- Approximate Pit F Enclosure Location**

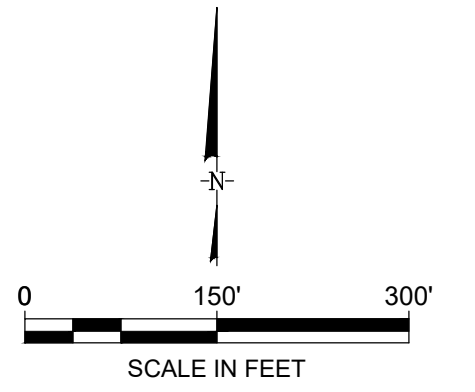

SITE LAYOUT ASCON LANDFILL SITE HUNTINGTON BEACH, CALIFORNIA		
	DATE: NOVEMBER 2016	FIGURE
	PROJECT NO. HC1457	2

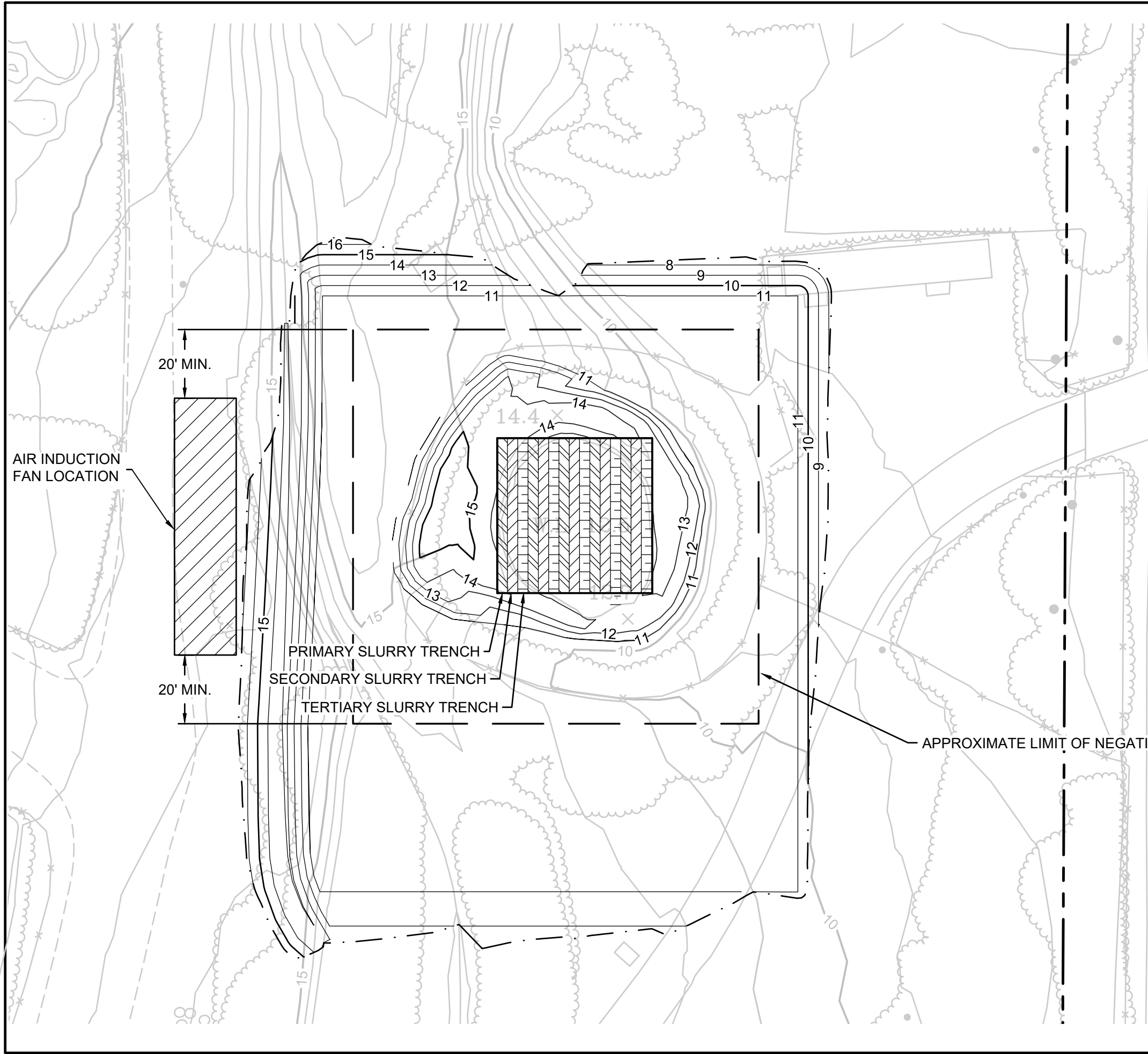

LEGEND

- 20 EXISTING GROUND MAJOR CONTOUR (5')
- EXISTING GROUND MINOR CONTOUR (1')
- 10 PROPOSED GRADING MAJOR CONTOUR (5')
- PROPOSED GRADING MINOR CONTOUR (1')
- PROPERTY LINE
- LIMITS OF GRADING
- PRIMARY SLURRY TRENCH
- SECONDARY SLURRY TRENCH
- TERTIARY SLURRY TRENCH
- APPROXIMATE LIMIT OF NEGATIVE-PRESSURE ENCLOSURE

NOTE

1. EXISTING GROUND TOPOGRAPHY AND SITE FEATURES ARE BASED ON AN AERIAL SURVEY CONDUCTED ON MARCH 30, 2011 BY COOPER AERIAL SURVEYS CO.

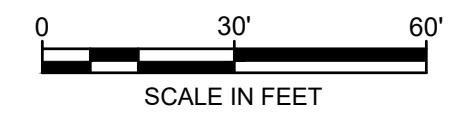

APPROXIMATE LIMIT OF NEGATIVE-PRESSURE ENCLOSURE

PIT F LAYOUT
 ASCON LANDFILL SITE
 HUNTINGTON BEACH, CALIFORNIA



DATE: FEBRUARY 2019
 PROJECT NO. HC1457

FIGURE
3

P:\PR\JSD\ADD\CADD\HC1457 ASCON LANDFILL\HC1457A-08\FIGURES\PIT F PFD_6.3.2021

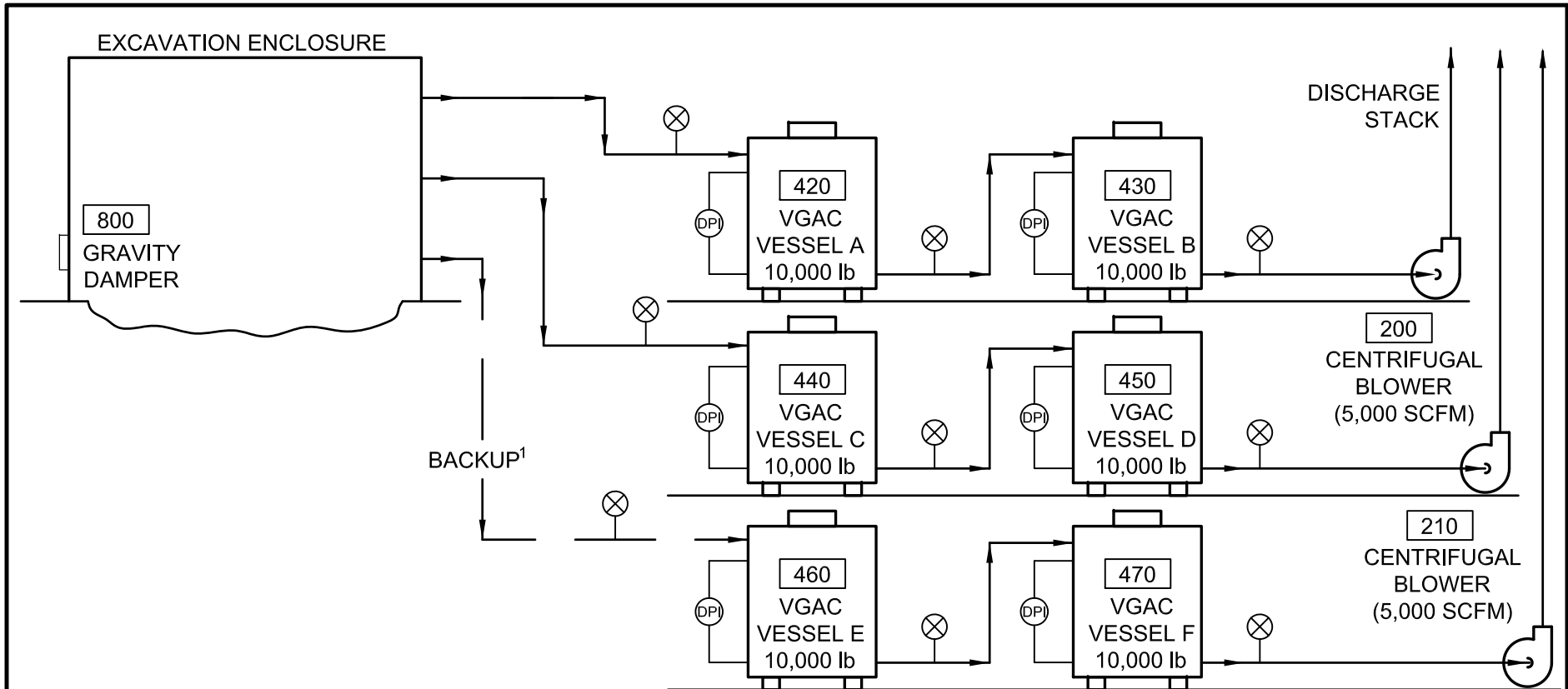

¹ ONLY TWO PARALLEL TRAINS
WILL BE OPERATED AT ANY ONE
TIME

LEGEND

- ⊗ FLOW CONTROLLING DAMPER
- Ⓟ PRESSURE INDICATOR
- Ⓧ DIFFERENTIAL PRESSURE INDICATOR
- ⊗ SAMPLE PORT
- VGAC VAPOR - PHASE GRANULAR ACTIVATED CARBON
- SCFM STANDARD CUBIC FEET PER MINUTE

PROCESS FLOW DIAGRAM PIT F TREATMENT SYSTEM ASCON LANDFILL SITE HUNTINGTON BEACH, CALIFORNIA	
 <small>engineers scientists innovators</small>	
PROJECT NO: HC1457	JUNE 2021
FIGURE 4	

Attachment E-Resumes



Dan Dowdy, PE
Principal

Project Roles

- ▶ Project Manager
- ▶ Field Inspections & Engineering

Specialties

- ▶ Process Engineering
- ▶ Emissions Compliance
- ▶ Program Management & Project Management
- ▶ Site Investigations and Feasibility Studies
- ▶ Remedial Design, Optimization, and Permitting
- ▶ Behavior Based Health and Safety
- ▶ Instrumentation and Controls

Education

- ▶ BS, Mechanical Engineering, University of California, Santa Barbara, 1992

Registration & Certifications

- ▶ California Professional Engineer, Mechanical, No. M30559
- ▶ Rule 403.1 Fugitive Dust Control Training, South Coast Air Quality Management District
- ▶ BP Safety Area Authority (AA) Skillful
- ▶ 40-Hour OSHA HAZWOPER 29 CFR 1920.120e
- ▶ 8-Hour OSHA HAZWOPER Refresher Course 29 CFR 1920.120e
- ▶ 8-Hour OSHA HAZWOPER Supervisor Training

Career Summary

Mr. Dowdy is a Principal Mechanical Engineer based in Geosyntec Consultants Santa Barbara operations with a focus on characterization, field investigations, and remedial systems focused on vapor capture and emissions management. His vapor experience is focused on hazardous waste sites, including industrial and manufacturing sites, upstream and midstream petroleum, and other highly emissive facilities. He has vast experience managing systems and teams focused on vapor, water, and chemical management in the environmental arena. Mr. Dowdy is experienced with turnkey remedial solutions including process engineering and design; system installations including constructability analyses; engineered system operations, monitoring, and performance optimization; off-grid power solutions; remote monitoring and data acquisition; instrumentation and controls; and is an expert at process troubleshooting (electrical and mechanical). Mr. Dowdy also has extensive experience in conducting feasibility studies, field investigations, construction management, preparing detailed cost analyses, and performance and compliance monitoring.

Relevant Project Experience

Confidential Forging Facility, Southern CA. Mr. Dowdy was the Engineer of Record for an engineering response to a SCAQMD issued Stipulated Order of Abatement requiring an active forging facility to curtail nuisance odors and reduce the potential for gaseous and particulate pollutant emissions. The four facility filtration systems processed a total of 144,000 cubic feet per minute, and each required modification. The significant challenges included very limited spatial footprints and an accelerated timeline to lift active curtailments. Mr. Dowdy was responsible for the mitigation development, feasibility testing, preliminary and final designs, agency permitting, construction outsourcing and execution, and reporting to meet the Order terms and timeline(s). Overall, multiple baghouse modifications were implemented along with serviceable inline HEPA and activated carbon filtration effectively reducing odors and particulate matter in alignment with the Order. Upon successful commissioning, the facility curtailments were eventually lifted.

Investigation and Remediation of Vinvale Terminal (Former Refinery, Active Tank Farm), Southern CA. Mr. Dowdy was the Engineer of Record for the remedial strategy and implementation for a leaded LNAPL release at a former refinery facility and currently an active tank farm situated within 1,000 feet of several municipal and private drinking water wells. Operations were conducted under SCAQMD Title V air emissions permit and tightly integrated with Terminal operations. The remedial Title V permit was restrictive having over 140 specific conditions creating a challenging emissions compliance strategy. Mr. Dowdy's work involved the preparation of source removal plans as well as contingency plans for the possibility of impacting the drinking water sources. The remedial strategies included several soil vapor extraction units, various liquid recovery systems, air sparging systems, and a vacuum enhanced liquid recovery system focused on increasing yields. Operations were conducted under SCAQMD Title V air emissions permit and tightly integrated with Terminal operations. The remedial Title V permit was restrictive having over 140 specific conditions creating a challenging emissions compliance strategy. Throughout the implementation, the systems were optimized to safely process at greater than 110% rated capacity while operating within the compliance window.

Dan Dowdy, PE

Investigation and Remediation of Chlorinated Solvent Impacts, Former Dry-Cleaning Facility under Environmental Liability Transfer, Gardena, CA. Mr. Dowdy was the Engineer of Record for project remedial efforts under an environmental liability transfer. Mr. Dowdy's responsibilities included the remedial strategy, cost estimating, regulatory compliance, aquifer and media injection testing, overall remedial design, air quality and construction permitting, component procurement, construction management, process control logic design and programming, remediation system operations and maintenance, and budget tracking. The remedial approach included soil vapor extraction, air sparge, and groundwater extraction/plume control ahead of enhanced in-situ reductive dichlorination.

Confidential Asphalt/Diesel Refinery, Southern CA. Mr. Dowdy was the Project Manager and Engineer of Record for site assessment and remedial activities at an active refinery. At the initiation of the project, minimal site assessment had been conducted and the extended team executed an assessment strategy in compliance with the Cleanup and Abatement Order while also integrating the long-term remedial goals into the assessment efforts. Mr. Dowdy designed and installed multiple remedial systems across the facility using innovative strategies included diverting soil vapors to process heaters as a supplemental fuel source, repurposing process wastewater within the refining processes, and using idled infrastructure for remedial efforts. Remote system controls and data acquisition systems were interfaced with Refinery operations including redundant safety measures.

Mine Tailings Impoundment Polishing Plant, Butte, MT. While seconded within the client Mining Function, Mr. Dowdy was accountable for the Design-Build delivery and commissioning of a 10-million gallon per day (mgd) water treatment and polishing facility treating metals impacted process water from an active mine tailings impoundment by redirection of flows from the active mining circuit to the facility under gravity conditions. The system included over 6 miles of influent and effluent piping between the mining circuit and outfall, multi-media filtration systems, reverse osmosis systems, instrumentation and control, chemical feed systems, and remote and localized monitoring capabilities. Mr. Dowdy was accountable for the overall organization, schedule management, safety metrics, contract adherence, project financials, and achievement and reporting of all internal protocols.

Confidential Asphalt/Diesel Refinery, Long Beach, CA. Mr. Dowdy was the Project Manager and Engineer of Record for ongoing site assessment and remedial activities at an idled refinery impacted by mixed light- and heavy-ended hydrocarbons. The initial remedial approach entailed a combination of thermal desorption, partial cryogenic recovery, and thermal destruction of the residual gas. Mr. Dowdy leadership included ongoing site assessment; groundwater monitoring and sampling; LNAPL recovery strategies; integration with existing refinery operations; Title V air permitting assistance; remedial systems design; equipment procurement; construction coordination and oversight; systems commissioning, and system operational planning and oversight.

Confidential Tank Farm and Transfer Facility Remediation, Lakewood, CA. Mr. Dowdy was the Technical Lead and Engineer of Record for an ongoing remedial action at an active tank farm and transfer facility impacted with JP-5 jet fuel. Significant challenges included a complex stratigraphy and shallow off-site impacts below residential areas. Multiple remedial approaches were applied to the site throughout the remedial lifecycle. In the final stages of the efforts, Mr. Dowdy led the closure alternatives analysis in support of the property redevelopment to residential parcels.

Plating Facility Wastewater Treatment Plant Repair, Fullerton, CA. Mr. Dowdy was the Project Manager and engineering lead for the repair of a 40,000 gallon per day throughput hexavalent chromium and other blended waste treatment plant where a 5-year CUPA certification identified multiple structural issues. Mr. Dowdy led the design of a parallel waste treatment system to provide uninterrupted facility operations during process and infrastructure repairs. Mr. Dowdy also provided management and oversight for the construction and transition of both systems.

Metals Treatment Lagoon Construction, Butte, MT. While seconded within the clients US Mining and Decommissioning Function, Mr. Dowdy was responsible for the management and delivery of the modifications surrounding a series of metals treatment lagoons within the Silver Bow Creek/Butte Area Superfund site. Due to the sensitive nature of the process, the entire infrastructure was designed with redundancy and under a detailed mean time to repair (MTTR) analysis to identify and pre-procure critical componentry. The project included the design and execution with the purpose of improving system functionality to protect adjacent surface waters through capture and removal of heavy metals (copper, cadmium, arsenic, and zinc) from area-wide storm and groundwater collection processes. The most significant complexity involved sustaining 24-hour operations while removing existing and reconstructing upgraded processes within similar footprints. A lime treatment system was redesigned along with lagoon structures, dredging capabilities, sludge decanting facilities, redundant transmission pipelines, remote data acquisition and controls, support buildings, utilities, and embankment modifications.

Natural Gas Plant Decommissioning, Ulysses, KS. While assigned within the clients US Mining and Decommissioning Function, Mr. Dowdy was responsible for the project management, decommissioning and environmental restoration

Dan Dowdy, PE

of an idled natural gas processing facility. Demolition of the facility included all above-ground structures (asbestos insulated fractioning towers, piping, compressors, buildings, etc.), subsurface foundations, subsurface piping and tanks, and other supporting infrastructure. Mr. Dowdy managed the decommissioning strategy and overall execution, internal and external facing planning documents, interfaced with legal support, and assisted with the negotiation of required regulatory permits.

Pipeline Decommissioning, Goleta, CA. While seconded inside client's the US Mining and Decommissioning Function, Mr. Dowdy was accountable for the removal of remaining segments of an abandoned pipeline that historically transferred oil and gas from onshore and offshore production wells along the Santa Barbara County coast. The project was encumbered by multiple complexities including, traversal of private properties and creek channels, multiparty and multiagency involvement, protected plant species, known and unknown Native American settlements, very limited access to several work areas, federally protected animal species, and noxious plants surrounding much of the pipeline. The project was successful delivered under strict permit conditions including zero release of hazardous materials or silt in waterways and limited disruption to the native habitat. Upon the completion of the removal activities, native habitat restoration was initiated.

Major Oil Company Portfolio Project Scoping, Southern CA. Mr. Dowdy was selected as the Lead Scoper for the assessment and remedial actions for a portfolio of approximately 250 sites. In the role, Mr. Dowdy was accountable for leading an internal and external team during assessment and engineering tasks included but not limited to developing characterization plans and paths to site closure, generation of agency work plans, assessment activity oversight, remedial action strategies, remedial pilot testing, remedial system designs, operation and maintenance guidance, and case closure requests (90% success ratio). Field execution under this portfolio was conducted by the client's field contractor under the direction of the Mr. Dowdy's team.



Maygan Cline, PG,
QSD/QSP
Principal

Project Roles

- ▶ Project Director/Quality Assurance

Specialties

- ▶ Project Management
- ▶ Stakeholder Engagement
- ▶ Phase I, II, and III Projects
- ▶ CEQA and Permitting SGMA Support
- ▶ Client Advocacy and Agency Engagement
- ▶ Strategic Thinking
- ▶ Site Investigation and Remediation
- ▶ Water Quality and Hydrogeologic Investigations
- ▶ Conceptual Site Model Development

Education

- ▶ BS, Geological Sciences, University of California, Santa Barbara, Santa Barbara, CA, 2007

Registration & Certifications

- ▶ Professional Geologist, California, No. 9117
- ▶ Qualified Stormwater Pollution Prevention Plan Developer and Practitioner (QSD/QSP): California No. 27414

Career Summary

Ms. Cline is an experienced Program and Project Manager for private-sector, industrial and local government municipal clients. Ms. Cline is also an experienced leader, able to manage, motivate, mentor and inspire cohesive technical and non-technical teams to develop and implement cost-effective and regulatory acceptable project strategies. She has extensive experience managing complex remedial investigations, pilot and feasibility studies and implementation of mitigation and/or remedial actions while creating and maintaining positive regulatory relationships while working toward project closure. Ms. Cline’s project experience includes investigation of a variety of contaminants of concern (TPH, LNAPL, VOCs, PFAS and metals) and media (soil, groundwater, surface water, vapor) and their potential affects to both human health and the environment. She has experience with CEQA, including planning and permitting proposed projects within the coastal zone of California. She has led and managed diverse technical teams, been a steward of health and safety, is versed in construction oversight as well as contractor bidding, selection, contracting and management. She has a proven track record of delivering commitments on-time and within budget. Ms. Cline has extensive stakeholder engagement experience with clients and the public, as well as local, state, and federal regulatory jurisdictions. Notable projects and select details are provided in the following sections.

Relevant Project Experience

Strategic Thinking and Regulatory Advocacy

Ms. Cline is versed in strategic planning for environmental impact liability and allocation for a variety of clients including legal, industrial, and municipal. Ms. Cline has provided strategic regulatory advocacy for local municipalities, sites with complex cleanup challenges in developed urban areas, and for large portfolios of work where technologies and regulatory consistency are key. Her strategic leadership has achieved mutually agreeable client and regulatory goals, and supported development of strong regulatory relationships.

Program Management

Ms. Cline is the Program Manager for a national portfolio of work supported by key technical experts across Geosyntec offices in North America. Ms. Cline leads regulatory advocacy efforts with multiple agencies and is responsible for maintaining technical consistency, sharing learnings and best practices broadly across all projects, and manages a diverse technical team to meet client objectives. Ms. Cline is also responsible for reserve budgets, accruals, estimating GHG baseline estimates and tracking cost savings for the portfolio.

Project Management

County of Santa Barbara, Resource Recovery and Waste Management Division, Santa Barbara County, CA. Support and manage various landfill compliance, monitoring and reporting, and mitigation needs for the County of Santa Barbara (COSB) Resource Recovery and Waste Management Division (RRWMD). Support includes groundwater assessment and monitoring, industrial stormwater compliance support, closed-landfill feasibility study updates, preparation of soil and waste acceptance policy documents, subsurface geologic and environmental management system modeling, groundwater modeling, water supply assessments, draft permit evaluation for new projects, agency engagement and response to PFAS investigative orders, and design evaluation of potential PFAS treatment options for landfill leachate.

Confidential Client, Santa Barbara County, CA. Project, client, and regulatory management for a former oil and gas storage facility owned by a joint venture of oil and gas companies. Health and safety stewardship led to achieving

Maygan Cline, PG, QSD/QSP

goal zero over the life of the project. Fostered strong working relationships amongst project team of 15+ individuals from various disciplines including, but not limited to, toxicology, hydrogeology, engineering, biology, CEQA/NEPA, archaeology, geotechnical. Extensive long-range (20-year horizon) cost estimation, budget management and cost savings tracking and reporting. Request for Proposal (RFP) preparation for five-year demolition, construction and restoration project. Contractor bidding, review and selection.

Stakeholder Engagement

Santa Ynez River Valley Groundwater Basin, Santa Barbara County, CA. Responsible for public outreach, communication, and engagement efforts pursuant to SGMA and Brown Act requirements. Manage technical teams in preparation of SGMA-compliant hydrogeologic technical studies. Responsible to present hydrogeologic technical information to public and citizen advisory groups, collect and document public comment for incorporation into final documents and submittal to the State. Coordinate with multi-consultant team to prepare SGMA-compliant GSP document for submittal to DWR. GSP submitted to DWR in January 2022.

Confidential Client, Santa Barbara County, CA. Responsible for private property owner and tenant communication and engagement, scheduling and coordinating sensitive indoor air sampling to assess the vapor intrusion pathway at the residence. Responsible for implementation of the overall site groundwater and vapor intrusion monitoring and reporting program, including conveying results to the property owner and tenant. Responsible for conveying complex technical information to the public in accordance with client goals, and assisting the CCRWQCB in the preparation of public fact sheets and response to public comments and concerns regarding vapor intrusion.

Glendale Superfund Site, Los Angeles County, CA. Residential stakeholder and U.S. Environmental Protection Agency (EPA) engagement and management. Coordinated all residential outreach and associated indoor air sampling activities with building tenants to support a Phase II Vapor Intrusion Field Investigation for the Glendale Superfund Site. Responsible as the main point of contact for all field activities, field staff, subcontractors, residents, and EPA lead. On-site for all indoor air sampling activities to answer resident questions, and provide support to field teams while collecting air data.

CEQA, Permitting and Compliance

Confidential Client, Santa Barbara County, CA. Preparation of detailed project description to support Coastal Development Permit acquisition in accordance with County of Santa Barbara Planning and Development Chapter 35, Article II – Coastal Zoning Ordinance. Managed multiple teams to complete CEQA initial studies and permit package submittals. Scheduled coordination meetings with local, state and federal jurisdictions to plan and scope the multi-year project. Permit acquisition from multiples agencies. Development of RFP for five-year demolition, construction and restoration project. Contractor bidding, selection, contracting and management.

Confidential Client, Santa Barbara County, CA. Preparation of a workplan describing the need for a sub-slab depressurization system to address identified vapor intrusion needs at a building adjacent to the project site. Obtained Central Coast Regional Water Quality Control Board Approval of the workplan and initiated design of the system. Responsible for obtaining permits for the system from the City of Santa Barbara Building and Safety Department (CEQA lead) and the Santa Barbara County Air Pollution Control District (APCD). Supported the City of Santa Barbara in evaluating CEQA applicability for the project, and obtained a variance pursuant to the Environmental Review Guidelines for the Santa Barbara County APCD (revised April 30, 2015), Appendix A.2 (*Equipment or Operations Exempt from CEQA*) specifically exempts onsite remediation of contaminated groundwater or soil using vapor extraction and treatment. Obtained ATC from the APCD and oversaw contractor installation of the system in accordance with City and APCD permit requirements. Prepared Emissions Verification Testing (EVT) report for submittal to APCD and received final PTO for the system. Responsible for on-going operations, maintenance and monitoring (OM&M) of the system field-management and oversight of hazardous waste handling to facilitate permit compliance.

Confidential Client, Los Angeles County, CA. Responsible for the daily operations, maintenance, compliance and reporting for multiple on-site remediation systems at a former refinery and chemical manufacturing facility in Los Angeles County. Responsible for on-site safety program, engagement with on-site facility operators, regulatory advocacy and engagement, and preparation of public information fact sheets distributed by the regulatory agency prior to initiating site investigative work at nearby, off-site properties. Responsible for all staff and subcontractor scope implementation within approved schedules and budgets.



Mark Grivetti, PG, CHG, CEG
Senior Principal

Project Roles

- ▶ Strategic Advisor

Specialties

- ▶ Investigation and Remediation
- ▶ Due Diligence Assessments
- ▶ Geologic and Hydrogeologic Evaluations
- ▶ Litigation Support

Education

- ▶ MA, Geology University of California, Santa Barbara, 1982
- ▶ BA, Geology, University of California, Santa Barbara, 1979

Registration & Certifications

- ▶ California Professional Geologist, No. 4272
- ▶ California Certified Hydrogeologist, No. 211
- ▶ California Certified Engineering Geologist, No. 1370

Career Summary

Mr. Mark C. Grivetti, PG, CHG, CEG, Senior Principal Hydrogeologist has a diverse background in projects related to hazardous waste characterization and remediation, evaluation of geologic hazards (including landslides and faults), and water supply development. He has extensive experience supporting Santa Barbara County including work at the Tajiguas, Ballard Canyon, Foxen Canyon landfills among other sites.

Mr. Grivetti formerly served as Geosyntec's Program Manager and Service Group Manager for the Santa Barbara County MSA Program since 2001 and previously served in that role for Dames & Moore/URS. Of particular note, Mr. Grivetti has overseen many of Geosyntec's MSA projects for the County including recent work related to generation of waste acceptance criteria for the Tajiguas Landfill and plume stability work at Ballard Canyon Landfill. He has been recognized by courts as a technical expert including supporting Santa Barbara County as an expert witness on several occasions. He has a proven track record of providing strategically sound solutions, responsive turnaround, and cost-effective work on these projects.

Relevant Project Experience

Technical Support on Various Projects, Tajiguas Landfill, Santa Barbara County, CA. Led various studies at the Tajiguas Landfill in Santa Barbara County including an extensive fault investigation, water supply development, evaluation of hydrogeologic conditions in the vicinity of a proposed subsurface barrier, surface water quality study for proposed expansion scenarios, and development of Soil and Waste Acceptance Criteria plans, and advisor on PFAS issues.

Geologic and Hydrogeologic Investigations, Ballard Canyon Landfill, Santa Barbara County, CA. Lead for geologic and hydrogeologic investigations at the Ballard Canyon Landfill in Santa Barbara County including groundwater modeling, plume stability evaluation, feasibility study, and continued evaluation of conditions to support closure.

Chicago Grade Landfill, San Luis Obispo County, CA. Oversight of work including design and permitting of new expansion cells, fault investigation, and monitoring issues. Led post-closure cost estimating and design of new cells.

Investigation and Risk Assessment, UST Site, Santa Barbara, CA. Mr. Grivetti led a team to evaluate potential vapor intrusion and other risk issues related to a former UST at a Santa Barbara County owned site. The work led the overseeing regulator to issue a No Further Action Letter for the site.

Facilitator, Carson Regional Groundwater Group, Carson, CA. Serves to facilitate the activities of several co-located major refineries and terminals in Southern California in their efforts to jointly address offsite oxygenate groundwater impacts. The work is focused on deep (500+ feet) aquifers used as the primary source of groundwater for municipal and domestic use in the Los Angeles Basin. In addition to coordinating and directing investigative work, he serves as liaison with Federal and State regulators (DTSC, RWQCB and EPA). His mission is to coordinate and build consensus among all Group members regarding evaluation of possible future impacts to groundwater producers in the area, as well as preparation and submittal of the results to regulators. Work has included preparation of RCRA EI submittals for the joint sites, drilling and testing of 28 deep monitoring wells (up to 600+'), and oversight of a \$1 million+ groundwater modeling effort for the project.

Water Supply Development, Various Locations. Project Geologist for specialized projects involving evaluation of yield and development of water resources at various sites in Southern California.

Evaluation of Sea Cliff Retreat and Stability, Santa Barbara County, CA. Completed several evaluations in support of proposed new development and other issues in the area. Included serving as an expert witness supporting Santa Barbara County and other entities in defense of wrongful death suit.

Induced Seismicity and Subsidence Evaluation, Southern CA. Evaluation to evaluate effects of new oil field production in an urban area in southern California. Work included evaluation of proposed drilling/production project and development of a long-term monitoring plan.



Kate Rantz Graf, PE
Principal

Project Roles

- ▶ Technical Advisor

Specialties

- ▶ Air Quality Permitting
- ▶ Regulatory Applicability Analysis
- ▶ Odor Evaluations
- ▶ Air Enforcement Case Strategy and Resolution
- ▶ Litigation Support and Expert Witness
- ▶ Compliance Management Assistance

Education

- ▶ BS, Chemical Engineering, Lehigh University, Bethlehem, PA

Registration & Certifications

- ▶ Delaware Professional Engineer, Environmental, No. #20177

Career Summary

Ms. Graf, a Principal with Geosyntec, specializes in providing air quality consulting services to industrial clients. She possesses more than 20 years of environmental engineering experience including regulatory compliance, permitting, and enforcement case resolution for industrial clients. Ms. Graf's past experience includes management of an air permitting division of a regulatory agency in the southwestern United States. She has assisted clients with obtaining major and minor source permits, including addressing New Source Review (NSR) and Prevention of Significant Deterioration (PSD) requirements, and compliance with new regulations. She has led compliance projects to enhance facility compliance and operational flexibility, to mitigate penalties for noncompliance, and to resolve alleged violations. For industrial facilities working to achieve carbon neutrality, Ms. Graf has performed carbon footprinting analyses and developed carbon neutrality plans. She has supported clients to address odor issues and has served as a technical expert in litigation matters.

Ms. Graf has applied her expertise nationwide across many industries, including cement, rock products, electric utility, asphalt, landfill, aerospace, metal recycling, manufacturing, and the legal services sector nationwide. Her industrial experience enables her to quickly understand a client's operation and potential emission issues. She has performed environmental compliance testing and regulatory review of emission test results. Her regulatory background coupled with her industrial knowledge provide a unique perspective to effectively and efficiently resolve permitting, compliance, testing and enforcement issues on behalf of her clients.

Relevant Project Experience

Odor Evaluations & Litigation Matters

Confidential Client, Rancho Cordova, CA. Provided technical oversight for a robust assessment of odor sources within a groundwater extraction and treatment system to identify potential odor-causing compounds and evaluate odor characteristics under worst-case operating conditions. Prepared an odor sampling plan and provided support for on-site field measurements and sampling. Air samples were collected and analyzed to identify individual odor-causing compounds and total odor levels. Field measurements were conducted using a Nasal Ranger® Olfactometer. Upon assessment of the concentration and identification of odor causing compounds, Geosyntec performed air dispersion modeling using the latest version of the American Meteorological Society/EPA Regulatory Model (AERMOD, Version 15181) to predict maximum odor levels at the system boundaries and at off-site receptor locations at varying distances from the emission points. The resulting odor units were compared to the odor detection thresholds.

Consulting Expert – Odor Litigation Matter, Confidential Client, PA. Ms. Graf served as Consulting expert for an odor litigation matter involving biosolids application on a farming operation. Ms. Graf led a team to conduct a field odor sampling assessment to identify the presence of odors at the client's property boundary and in the surrounding community. Ms. Graf prepared an odor sampling plan and identified sampling locations upwind and downwind of the potential source, in the nearby community, and near plaintiff's homes. The sampling plan detailed procedures and equipment to be utilized for characterizing odor sources and collection of field measurements and ambient air samples for laboratory analysis of odor-causing compounds. Field measurements were collected using a Nasal Ranger® Olfactometer (Nasal Ranger®), a "state-of-the-art" field olfactometry device for measuring and quantifying odor strength in the ambient air. Based on the survey results, a technical memorandum was prepared detailing the sampling results and identifying potential off-site impacts.

Odor Litigation Expert, Confidential Client, Indianapolis, IN. Ms. Graf provided technical assistance for a litigation matter involving odor complaints against an industrial source. Ms. Graf reviewed the historical record, site-specific

Kate Rantz Graf, PE

documentation, Plaintiff's complaints and expert reports, and conducted a site visit to observe facility operations. Following this assessment, Ms. Graf prepared an expert report regarding the viability of the Plaintiff's claims. The Plaintiffs agreed to a settlement in the matter prior to court.

Odor Litigation Expert, Confidential Client, GA. Ms. Graf served as Project Director for an odor assessment conducted to address a litigation matter for a farming operation in Georgia. Ms. Graf led a Geosyntec team to conduct a field odor sampling survey during normal operations and during operations that have the potential to generate increased odors. Measurements were obtained onsite and offsite to identify odor characteristics and intensity. Data from the field survey was utilized to assess the potential odor impacts associated with the Plaintiff's residence. The survey was designed to identify the potential for odors to be observed at levels that may be considered a nuisance or harmful at the Plaintiff's residence. Meteorological data was evaluated in conjunction with the field data and a summary memorandum was prepared that detailed the odor survey results and meteorological data for the area under attorney client privilege. Ms. Graf utilized the odor survey data, site specific information, and her knowledge of air quality to generate an expert report. The matter was resolved when the Plaintiff dropped the case.

Consulting Expert – Ozone Depleting Substances Litigation Support, Confidential Client, TX. Ms. Graf provided litigation support to an industrial manufacturing client to address an alleged compliance issue related to ozone depleting substances (ODS). Ms. Graf's technical assistance included an assessment of the ODS regulations and preparation of documentation detailing the nexus of the regulations with the clients' operations in the form of a technical memorandum. The memorandum was submitted to USEPA to obtain concurrence with the regulatory interpretation. As a result of the regulatory interpretation, the clients' operations were no longer subject to the litigation.

Air Quality Permitting, Impact Assessments, and Modeling

PSD Modification for Power Plant, Pima County Air Quality Department (PCAQD), Tucson, AZ. Led a team in support of the regulatory agency to issue a major PSD permit modification for the Tucson Electric Power Sundt Generating Station. The project added 10 new reciprocating internal combustion engines (RICE). Geosyntec reviewed the permit application and developed the PSD permit, BACT Analysis, emission calculations, and the ambient air impact analysis on behalf of the regulatory agency. Geosyntec participated in the public meetings and public information sessions and developed the response to public comments.

Air Quality Impact Assessment, Department of Energy (DOE) Site, Portsmouth, OH. Ms. Graf provided technical leadership to conduct an air quality impact assessment of the decommissioning and deconstruction of a DOE facility. The evaluation included the calculation of emissions of particulate matter, volatile organic compounds, hazardous air pollutants, and radionuclides. The resulting emission rates were utilized to conduct dispersion modeling to assess the maximum potential offsite impact from the operations related to the demolition of buildings, soil remediation, and waste disposal.

Air Permitting of an Industrial Gas Plant, Confidential Client, AZ. Led a project to provide air permitting assistance to an industrial gas supplier for a greenfield plant in Arizona. Prepared emission calculations and conducted a regulatory applicability analysis for the new facility. Addressed agency concerns about the facility being collocated with other facilities and obtained concurrence that the facility was not to be considered as a single, combined source (with the other facilities) for the purposes of Title V and New Source Review.

New Chemical Facility Permit, Keystone Industries, Gibbstown, NJ. Prepared an air quality preconstruction permit application for a new chemical manufacturing facility operation including a chemical tank farm and truck unloading operations. Included an evaluation of potential emissions based on proposed operational conditions and batch information. Prepared permit application documentation for submittal. Permit application package was submitted through the NJDEP RADIUS application process.

Chemical Facility Permit Modification Application, RB Manufacturing, Hillsborough, NJ. Prepared air quality preconstruction permit modification application for a minor source facility. Requested modifications to facility operations included tank throughput rates and chemical usage. Revised emission calculations were developed and the modification application was submitted through the NJDEP RADIUS application process.

PFAS Emissions Assessment, Confidential Client. Ms. Graf supported a confidential client to evaluate estimated site-wide PFAS emissions rates and emissions reductions from a manufacturing operation. The evaluation was triggered following the finding of elevated concentrations PFAS chemicals in ambient air, soil, and water near the Site. Multiple data sources were analyzed, including operations data, source testing data, air dispersion modeling results, ambient air monitoring data, and atmospheric deposition sampling data. The data was correlated to assess whether

Kate Rantz Graf, PE

the site's emissions inventory was comprehensive, and whether the emissions control equipment installed was sufficiently effective to mitigate emissions.

PSD Air Permit Modification, Pima County Air Quality Department (PCAQD), Tucson, AZ. On behalf of PCAQD, Ms. Graf led a PSD review for a modification of the El Paso Natural Gas (EPNG) compressor station air permit. Three (3) natural gas fired General Electric (GE) Frame III turbines drive compressor units to compress the natural gas. The modification added gas cooling equipment (e.g., piping, valves, fans) and gas recycling to allow for operational flexibility. The permit review included a review of post-change potential emissions and a netting analysis to avoid PSD. Operational limitations were incorporated into the permit to avoid PSD. An additional emergency generator was added as part of the modification. A full regulatory applicability evaluation and permit limits were established for the proposed natural gas-fired emergency generator in accordance with New Source Performance Standards (NSPS) Subpart A and Subpart JJJJ. The draft permit and technical support document were prepared for public notice. Ms. Graf participated in the public hearing and prepared responses to public and EPA review comments. Minimal comments were received from EPA and the permit was issued within the requested timeframe to meet EPNG's project schedule.

Strategic PSD Air Permit Modification Impact Assessment, New Harquahala Generating Company, Tonopah, AZ. Evaluated proposed new operating scenario for regulatory impact. Completed a review and assessment of prior consultant evaluation of the proposed change. Provided client with recommendations of how to implement the proposed change with minimal permit processing time and avoid local and federal BACT triggers.

PSD Air Modeling Support Services, Confidential Power Industry Client, NC. Provided senior review and support for Prevention of Significant Deterioration (PSD) air modeling for a proposed natural gas fired electric generating station. Modeling tasks included screening of potential sources to be included in the National Ambient Air Quality Standards (NAAQS) and PSD increment modeling for emissions of carbon monoxide, nitrogen oxides (NO_x), and particulate matter less than 2.5 micron in diameter (PM_{2.5}). Provided support for the preparation of the PSD air modeling report for submittal to the North Carolina Department of Environment and Natural Resources (NC DENR).

Air Permitting and Environmental Impact Report (EIR) Support, Ascon Landfill Site, Huntington Beach, CA. Provided support for the Ascon Landfill Site, a multi-party PRP site under Cal-EPA, Department of Toxic Substance Control (DTSC) Consent Order for remedial action. Services include air permitting support for a proposed volatile organic compound (VOC) containment and treatment system to be utilized during impacted soil consolidation and capping activities. Calculated potential emissions from proposed remediation including a review of URBEMIS model results for heavy construction equipment emissions. Prepared permit application for submittal to South Coast Air Quality Management District (SCAQMD).

Title V Air Quality Permit Application Assistance, Motiva Enterprises, multiple locations in NJ and NY. Prepared Title V air quality permit applications for permit modifications and renewals for refinery operations in New York and New Jersey. Applications were developed to address facility changes including: operational changes, fuel throughput changes, new regulatory requirements, and equipment modifications (tank seal changes, etc.).

Synthetic Minor Permit Application Development, BFG International, Peekskill, NY. Prepared an initial synthetic minor source air permit application for a new fiberglass composite manufacturing facility. Developed permit application documentation including process description and preparation of emissions calculations of volatile organic compounds (VOCs) and hazardous air pollutants (HAPs) for complex resin transfer molding and open molding operations, paint booths, and curing operations, to restrict the emission to below major source HAP levels. For later facility modifications, permit modification applications were prepared, including updated emission calculations and modeling of air emissions to demonstrate compliance with the New York Department of Environmental Conservation (NYSDEC) Annual and Short-Term Guideline Concentrations for toxic ambient air contaminants. Provided support for public meetings associated with the environmental justice requirements and preparation of the Environmental Justice Public Participation Final Report.

Air Pollution Control Device Selection and Permitting, Confidential Client, Newark, NJ. Conducted various air services for a large scale in-situ remediation project in Newark, NJ. Responsible for air pollution control device sizing and selection, development of specification documents, and air permitting for a new remediation treatment technology, Self-sustaining Treatment for Active Remediation (STAR). Managed preparation of the air permit application, including emissions calculations, and documentation for submittal using New Jersey Department of Environmental Protection (NJDEP) RADIUS software.

Regulatory Agency Experience

Kate Rantz Graf, PE

Air Quality Permitting Division Manager, Maricopa County Air Quality Department, Phoenix, AZ. Managed permitting division for air quality agency, overseeing all major and minor source permits processed by the agency. Responsible for implementation of air permitting program changes in response to EPA Notice of Deficiency. Oversaw preparation of permit documentation including process diagrams, emission calculations, equipment documentation, operation and maintenance plans, proposed permit language, and compliance records. Led discussions between applicants, legal counsel, and agency personnel to streamline permit requirements and provide optimal flexibility for applicants. Negotiated permit language, testing requirements, and compliance requirements to assure compliance with applicable regulations. Acted as liaison between agency and EPA Regional personnel for numerous contentious Title V permits. Led public meetings on behalf of agency and provided information for public review of proposed permits. Represented agency in administrative appeal of permits and in discussions with EPA Regional staff. Provided support for rule development efforts, State Implementation Plan (SIP) revisions, and enforcement negotiations.

Compliance Management Assistance

Facility Evaluation and Compliance Review, ColArt, Piscataway, NJ. Conducted facility evaluation to determine applicability of New Jersey TCPA regulations. Led team to conduct on-site process safety review which included process hazard evaluation, personnel interviews, and preparation of report detailing findings and potential areas for improvement. Provided oversight of client team to develop safety procedures, personnel training, and environmental reporting programs.

Title V Air Quality Permit Compliance Assistance, Confidential Roofing Manufacturing Client, NJ. Assisted client with annual Title V compliance tasks including annual compliance certification, emission inventories, semiannual compliance certifications, and deviation reporting. Specific tasks included assessment of site compliance, emission calculations, and documentation of deviations from air permit and regulatory requirements. Provided support to develop enhanced compliance programs and training to new plant personnel on Title V permit requirements and air regulations. Developed compliance tracking tool to assist client with maintaining compliance with complex permit conditions and assisted client with efforts to streamline existing permit through permit modification.

Air Quality and Storm Water Compliance Assessment and Consulting Services, Goodrich Engine Components, Tempe and Chandler, AZ. Project Director for storm water and air quality compliance services project for (2) aerospace manufacturing facilities. Managed audits of two facilities to determine compliance with Maricopa County Air Quality Department (MCAQD) Air Regulations, including evaluation of facility equipment and operations and development of potential and actual air emission calculation spreadsheets. Prepared air permit modifications and renewal applications. Project also included preparation of Storm Water Pollution Prevention Plans (SWPPP) for metal fabrication operations at both facilities and preparation of a Spill Prevention, Control, and Countermeasure (SPCC) Plan for the Chandler, Arizona facility. Assisted the client in identifying potential pollutant sources and recommend Best Management Practices (BMPs) for contamination reduction strategies.

Emissions Inventory and Tracking Tool Development, Confidential Defense Contractor Client, Confidential Location. Project Director for project involving the preparation of annual air emissions inventory reports for a defense contractor facility. Reviewed annual chemical usage, vehicle miles traveled, and process data used to generate emission inventory report. Also led development of a new air emissions tracking tool for implementation by client to streamline emission tracking and reporting.

Stack Testing Oversight, Shell Oil Products US, various facilities in IL. Provided technical leadership to complete stack testing as required by the local regulatory agency at multiple locations. Obtained proposals from stack testing firms, selected the testing firm, prepared the stack testing protocol for agency approval prior to testing, managed staff onsite during testing, and developed final test report for review and approval by regulatory agency.

Air Quality Audit and Compliance Assessment, L'Oreal, Somerset, NJ. Conducted facility evaluation to determine compliance with existing air permit requirements. On-site audit included an equipment inventory assessment, facility compliance requirement review, personnel interviews, and records review. Prepared report detailing audit findings and potential areas for improvement.

Air Quality Permit Evaluation, Confidential Client, Mesa, AZ. Performed a site audit and evaluation of the air quality permit for a propellant device manufacturing facility. Developed a plan for improving facility compliance, including updated recordkeeping and reporting strategies, as well as revisions to the permit designed to clarify compliance requirements.



Susan "Ruth" Custance,
MPH
Senior Principal

Project Roles

- ▶ Public Involvement/Risk Communication

Specialties

- ▶ Human Health Risk Assessment
- ▶ Risk Management and Communication
- ▶ CERCLA/RCRA Risk Assessments
- ▶ Risk-Based Corrective Action
- ▶ Data Analysis and Exposure Assessment

Education

- ▶ MPH, Environmental Health, University of Michigan School of Public Health, Ann Arbor, Michigan, 1989
- ▶ BA, Microbiology, University of California, San Diego, San Diego, California, 1987

Career Summary

Ms. Ruth Custance is a senior principal environmental scientist based in California specializing in risk assessment, Brownfield's redevelopment, and program management. For over 25 years, Ms. Custance has lead project teams in the use of risk assessment and data analysis to evaluate potential health risks and develop effective remedial approaches. She has conducted risk assessments under state and federal superfund programs, RCRA and state voluntary cleanup programs for numerous constituents such as chlorinated solvents, petroleum hydrocarbons, polynuclear aromatic hydrocarbons (PAHs), metals, PCBs and dioxins.

Much of her project experience includes conducting risk assessments for complex high-profile sites including major landfill or petroleum impacted sites in proximity to sensitive land uses. Her work has included developing programs to evaluate potential offsite emissions from these facilities considering adjacent residential or school-based land uses. In addition, her work has included using risk assessment for assessment and permitting associated with site development and construction projects. Over the last several years, Ms. Custance has led a technical team in evaluating PCBs in building materials and indoor air and developing assessment and mitigation procedures.

Relevant Project Experience

Air Monitoring Program, Data Analysis and Regulatory Liaison. Aliso Canyon Storage Facility, Southern CA. Ms. Custance was one of the lead professionals on monitoring and evaluating emissions from a large natural gas leak in Southern California. She directed a team of scientists in coordinating data collection within the facility, facility perimeter and community locations and data analysis for use in evaluating ambient air quality on a daily basis. Work included development of a data review program, database and reporting procedures and interfacing with the Los Angeles County health department, Los Angeles Unified School District, South Coast Air Quality Management District and the California Air Resources Board on a weekly basis with respect to the data findings.

Odor and Risk Assessment Support and Air Dispersion Modeling. Honor Rancho Gas Storage Facility, Southern CA. Following the identification of a historical odorant release (tetrahydrothiophene and tert-butyl-mercaptan) in 2019, Geosyntec supported SoCalGas through an extensive investigation to evaluate the vertical/lateral limits of odorant impacts in soil and soil vapor in support of a natural gas header replacement project. Project work involved developing compound-specific Human Health Screening Levels (HHSLs) and nuisance odor thresholds and site-specific air-dispersion modeling to delineate the areas where (during excavation) there may be elevated risk for construction workers, and where soil disturbance may generate nuisance odors capable of migrating offsite to sensitive receptors.

Risk Assessment, Emissions Impact Evaluation and Air Monitoring Adjacent to Residential Neighborhood and High School, Ascon Landfill Site, Huntington Beach, CA. Ms. Custance is the lead consultant on air emissions monitoring and human health risk assessment issues for a petroleum waste landfill site. She conducted a risk assessment to quantify risks and noncancer hazards from volatile chemical emissions and co-developed an ambient air monitoring plan that was used to evaluate the risk assessment results and provided measurement data for risk communication. Additional risk assessment work entailed evaluating exposures to soil, soil vapor and groundwater for human health impacts and potential ecological impacts from groundwater migration to a nearby surface water channel, and participation in public meetings throughout the project. For the Environmental Impact Report (EIR), Ms. Custance provided third-party review of the air quality and air quality risk assessment sections of the EIR being conducted by the States' contractor. As a part of four remediation projects, Ms. Custance developed the air monitoring plan and oversaw the data analysis and reporting to the local air quality district and state agency as well as provided risk communication support to the project.

Susan “Ruth” Custance, MPH

Sitewide Odor Assessment Study, Ascon Landfill Site, Huntington Beach, CA. An Odor Assessment was conducted to assess potential odor emissions for remediation of a petroleum waste landfill. The investigation included in-situ and ex-situ soil vapor sampling for chemical and odor analysis. As a part of the odor assessment, research was conducted to determine potential odor causing chemicals in the waste and the appropriate analytical methods for analysis. In addition to odor causing potential, data were reviewed with respect to potential toxic effects of measured concentrations. The data were interpreted using a three-dimensional data visualization model. Correlations between measured and modeled odor parameters and chemical composition of the soil vapor sampling were used to assess potential emissions to outdoor air during excavation activities and to identify areas of higher odor causing potential to aid in remedial action planning.

Risk Assessment and Data Evaluation for Shell Carson Terminal (400+acre Former Refinery, Active Tank Farm, and Chemical Storage Facility), Carson, CA. Ms. Custance is providing senior risk assessment oversight for evaluating indoor air, soil, soil gas and groundwater data for the Shell Carson Facility. The site is the location of a former refinery and current storage facility. Ms. Custance provided technical support in developing a risk-based strategy to finalize the Remedial Investigation sampling and is the lead risk assessor developing the baseline risk assessment for the site. The results of the risk assessment work will be used to develop an overall comprehensive risk-based strategy for addressing the site. As a part of the risk assessment, soil gas and indoor and outdoor air quality were assessed.

Post-fire Air Quality Monitoring and Data Evaluation. Frank R. Bowerman Landfill. Orange County, CA. The Frank R. Bowerman landfill gas collection system was impaired as a result of the Silverado Fire in 2020. As a result, odorous emissions were of a concern to the neighboring community. Ms. Custance developed an air monitoring plan to assess potential health effects within the community as the landfill systems were repaired. Work entailed regular air monitoring at the facility perimeter and within the adjacent community, data evaluation, and risk assessment. Ms. Custance also participated in weekly and monthly meetings to present the results of the monitoring and support county staff in public outreach post-fire.

Risk Assessment and Emissions Air Monitoring, Casmalia Resources Federal Superfund Site, CA. Ms. Custance was the project manager for the baseline human health risk assessment for the Casmalia Remediation Federal Superfund site and a project team member for the Remedial Investigation and Feasibility Study. This site is a former RCRA Class I Hazardous Waste Management Facility that accepted a variety of wastes from oil, aerospace, and other industries. As a part of Geosyntec’s involvement at the Site, Ms. Custance oversaw the perimeter air monitoring program required by USEPA to evaluate potential offsite migration of VOC emissions from the Site. The work involved developing the air monitoring plan and deploying the equipment for continuous VOC monitoring at several locations. Periodic reporting was required by USEPA. Additional support was provided developing remedial action objectives and cleanup goals for the Feasibility Study.

Residential Neighborhood Risk Assessment, Carson, CA. Ms. Custance provided senior risk assessment oversight for a historical crude oil storage facility that was developed as a residential neighborhood. A phased approach has been developed to provide screening of potential risks from chemicals detected in soil, soil vapor and indoor air at the Site for use in interim action planning. Database and graphical assessment tools have been developed to allow for an efficient comparison of site data to risk-based screening levels, background concentrations and outdoor and indoor air results. Baseline risk assessment and risk-based cleanup goals have been developed for petroleum hydrocarbons, PAHs, metals such as arsenic and lead and Volatile Organic Chemicals (VOCs).



Juliann Chen, MPH
Senior Scientist

Project Roles

- ▶ Public Involvement/Risk Communication

Specialties

- ▶ Human Health Risk Assessment
- ▶ Site Investigations and Vapor Intrusion
- ▶ Product Safety and Compliance
- ▶ Toxicology

Education

- ▶ MPH, Environmental Health Science, University of California, Berkeley
- ▶ BS, Integrative Biology, University of California, Berkeley

Career Summary

Ms. Chen has over 18 years of experience in project management and environmental consulting including human health risk assessments, environmental health and safety, product safety and compliance (including Proposition 65), toxicology, and litigation support. She has extensive experience working on risk assessments for former manufactured gas plant sites in California, and thus she has a detailed understanding of the numerous different California regulatory programs and risk assessment guidance. Additionally, she has extensive litigation support experience in performing critical evaluations of the toxicological literature, evaluating potential causal associations between chemical exposures and documented adverse health effects. Most recently, Ms. Chen completed a Proposition 65 dermal exposure evaluation to hexavalent chromium using ratchet tie down buckles, including designing a sampling protocol and working with an analytical laboratory on methodology to minimize reduction of Cr6+ to Cr3+ during the sampling process.

Relevant Project Experience

Site Investigation Project, Confidential Client, Confidential Location, CA. Ms. Chen was asked to review existing data and, if needed, identify data gaps to complete a site-specific risk assessment. Due to past historical operations performed on the property, additional soil samples were recommended for the analysis of petroleum hydrocarbons, metals, and semi-volatile organic compounds. The data gaps evaluation was completed as part of the Remedial Investigation (RI) report to support preparation of a human health risk assessment for an active refinery site. The RI will be submitted to the Los Angeles Regional Water Quality Control Board.

Vapor Intrusion Pathway Analysis, Confidential Client, South San Francisco, CA. Ms. Chen prepared a human health risk assessment (HHRA) to evaluate potential exposures to chlorinated chemicals detected in soil vapor for a future commercial/industrial use scenario. The vapor intrusion evaluation included developing site-specific target levels using site-specific attenuation factors from paired sub-slab/subsurface soil vapor and indoor air data. The HHRA was submitted to the San Mateo County Environmental Health Services Division.

Vapor Intrusion Pathway Analysis, Confidential Client, Los Angeles, CA. Ms. Chen prepared a health risk assessment to evaluate potential exposures to chemicals detected in soil vapor for an aerospace manufacturing facility. The vapor intrusion evaluation included evaluating paired sub-slab soil vapor and indoor air data for both cool and warm season investigations. The RI was submitted to the Los Angeles Regional Water Quality Control Board.

Risk Assessment, Confidential Client, Carson, CA. Ms. Chen was the lead risk assessor for a former petroleum refinery and chemicals manufacturing facility that is approximately 450 acres in size with multiple detected chemicals. Work entailed all steps in preparation of the risk assessment for submittal to the Los Angeles Regional Water Quality Control Board. The primary chemicals of potential concern are volatile and semi-volatile organic chemicals, total petroleum hydrocarbons, and metals in soil, soil vapor, indoor air, and/or groundwater. Target Cleanup Goals for chemicals of concern in soil and soil vapor were also derived to identify impacted areas for remedial evaluation in the Feasibility Study.

Joint Base Elmendorf-Richardson (JBER), United States Air Force, AL. Ms. Chen was the lead risk assessor or provided senior review for CERCLA HHRAs for various sites included within JBER and following ADEC risk assessment guidance. The HHRA included a multi-pathway exposure evaluation to chemicals detected in soil and ground water (ingestion and vapor intrusion). Contaminants of concern included metals, volatile organic compounds, semi-volatile organic compounds, and pesticides.

Risk Assessment, Confidential Client, Confidential Location, CA. Ms. Chen conducted a risk assessment to evaluate the potential risks from exposure to polycyclic aromatic hydrocarbons (PAHs) and polychlorinated biphenyls (PCBs) for workers and recreational visitors from direct contact with soil. Asbestos was additionally evaluated, as were PCBs under Toxic Substances Control Act (TSCA). The objectives of the project were to assess the lateral and vertical

Juliann Chen

extent of PCBs, PAHs, and asbestos in soil, conduct human and ecological risk assessments for PAHs and PCBs, and characterize the disposition of bulk product waste. Site-specific risk-based screening levels (RBSLs) were derived for workers and recreational visitors for comparison to soil analytical results to calculate potential risks.

Former Manufacturing Gas Plant (MGP) Facilities, Pacific Gas and Electric Company, Various Locations, CA. Ms. Chen completed human health risk assessments for more than 15 individual MGP sites located throughout California. The risk assessments have evaluated a wide range of potential land uses, including residential, commercial/industrial, and recreational. The chemicals of concern at most of the Sites include PAHs, inorganics, petroleum compounds, volatile constituents, and cyanide. The risk assessments were completed under the oversight of the California Environmental Protection Agency, and provided the basis for the development of health-protective remedial strategies.

Risk Assessment, Confidential Client, Confidential Location, CA. Ms. Chen conducted a CERCLA (Superfund) risk assessment for a site involving the evaluation of multi-pathway exposure to chemicals detected in soil, sediment, air, ground water, and surface water. Contaminants of concern were predominantly pesticides, but also included metals, volatile organics compounds, and semi-volatile organic compounds.



David Oliver, CCM
**Senior Construction
Manager**

Project Roles

- ▶ Field Inspections & Engineering

Specialties

- ▶ Project Management/Controls
- ▶ Construction Estimating
- ▶ Design Review for Constructability
- ▶ Quality Assurance/Quality Control
- ▶ Problem Resolution, Contract Administration
- ▶ Project Health and Safety

Education

- ▶ BS, Construction Engineering, California State Polytechnic University, San Luis Obispo, CA, 1982

Registration & Certifications

- ▶ Certified Construction Manager (CCM), Construction Management Association of America
- ▶ 40-hour OSHA training in compliance with 29 CFR 1910.120
- ▶ 8-hour OSHA Supervisor Training in compliance with 29 CFR 1910.120
- ▶ 8-hour OSHA Excavation, Safety, Competent Person Training
- ▶ 8-hour OSHA Refresher Course in Health and Safety for Hazardous Waste Site Operations

Career Summary

David Oliver, CCM, is senior construction manager with experience in California's public and private sectors, including general construction and environmental remediation. His experience includes construction management of fixed price and design build projects, and review of contract documents for value engineering and constructability. In addition, he has had many years of varied and extensive experience in multidisciplinary project permitting, problem resolution, contract administration, project controls and quality assurance/quality control (QA/QC). This experience includes public works projects, California State Parks projects, commercial vertical construction, facility demolitions, Brownfield Redevelopment; water treatment system facility installations that include groundwater, industrial wastewater and drinking water systems, soil remediation; soil vapor extraction; landfill leachate, landfill gas control systems, and landfill closures. Past management experience has included construction cost estimating, design support and construction management oversight for the installation of underground pipeline and utility systems, wet and dry mechanical systems, electrical and controls systems, grading, paving, concrete, landscaping, landfill construction, and California State Parks ADA and park improvement projects. The contract value of the various projects that were estimated and managed, ranged from \$25,000 to \$18.2M and had project durations of 3 weeks to 3.5 years.

Relevant Project Experience

Design/Build Groundwater Remedial Construction Project, Gould Electronics, El Monte, CA. Managing the construction and general construction effort for the groundwater remediation pipeline and treatment system installation. Work included the installation of 16,500 linear feet of 8" and 10"x6" double contained recovery well pipeline and 4,000 linear feet of reinjection piping. Work includes included installation of 8 recovery wells and 3 re-injection wells, installation of a 350 gpm and 700 gpm groundwater treatment system with PLC based control system and offsite well management telemetry system, control building, site landscaping and final grading for SWPPP compliance. The 700 gpm treatment system treats the water for delivery to the City of El Monte water drinking supply. Work included complete Construction Management oversight of multiple subcontractors, preparation of cost estimates, project schedules, value engineering proposals and project cost controls for this 18-month, \$12.8 million project.

Constructability and Reviews, Owner's Engineer Services, Confidential San Gabriel Valley Impaired Water Treatment Plant, CA. Performed constructability reviews, assessed construction risks and conflicts, prepared bid packages, and advised on contracting strategy for an impaired groundwater treatment system containing extraction wells, miles of pipelines, activated carbon, ion exchange, media filtration, advanced oxidation, and reverse osmosis prior to drinking water end use.

Design/Build Groundwater Remedial Construction Project, Olin Corporation, Morgan Hill, CA. Managed the construction and general construction effort for the groundwater remediation pipeline and treatment system installation. Work included the installation of 6,500 linear feet of 8" recovery well pipeline via directional boring and 4,500 linear feet of reinjection piping. Work also included demolition of the former treatment system, installation of a 750 gpm groundwater treatment system with PLC based control system and offsite well management telemetry system, control building, site landscaping and final grading for SWPPP compliance. Work included complete Construction Management oversight of multiple subcontractor, preparation of cost estimates, project schedules, value engineering proposals and project cost controls for this 8-month, \$4.6 million project.

Design/Build Construction Management Landfill Closure, Geo Thermal, Inc., Middletown, CA. Managed the construction of the Geo Thermal landfill closure project located in Middletown, CA. Work included the solidification and relocation of 132,000 cubic yards (CY) of geo thermal waste located in 7 former containment ponds, removal and solidification

David Oliver, CCM

of 114,000 cy of waste from two burial trenches up to 30 feet deep and in contact with groundwater, installation and operation of two 600,000 SF thin film solar evaporators (TFSE) and spray systems to remove 84,000,000 gallons of contact water, solidification of 105,000 gallons of pH 1.2 brine waste, cap closure of waste under 18 acres of HDPE/GeoNet drainage layer, relocation of 385,000 CY of onsite soil borrow utilized for closure cap and waste solidification, final grading activities for the 120 acre construction area, modification to Freeman Lake spillway to lower lake by 10 feet, installation of 3.87 acres of enhanced wetlands, installation of groundwater irrigation system, installation of 1.3 million gallon irrigation/fire water tank, installation of 21,000 phyto-remediation trees and above ground irrigation system, installation of fire water suppression system and coordination with all agencies, subcontractors and clients for this 2.5-year \$13.5 million project.

Demolition, Former Criterion Catalyst Site, Azusa, CA. Served as the Project Management Consultant for Criterion Catalyst for the successful demolition of the former manufacturing facilities and served as Project Manager for the sites remediation activities. The project included the removal and disposal of asbestos and lead-laden building products, underground concrete encased transite piping, and underground chemical storage and acid neutralization vaults. Work also included soil excavation, soil sampling, off-site disposal and compaction of 12,000 yards of soil to allow site redevelopment. Work included cost control management and subcontractor coordination for this project totaling \$3.6 million over a 7-month period.

Demolition, Former Fairchild Semiconductor Corporation Site, Mountain View, CA. Served as managing contractor for the successful demolition of eight former Fairchild manufacturing and two waste water treatment facilities. Projects included the removal and disposal of asbestos and lead-laden building products, underground concrete encased transite piping, and underground chemical storage and acid neutralization vaults. Work also included soil excavation, soil sampling, on-site soil aeration, off-site disposal and import backfill and compaction of 23,000 yards of soil to allow site redevelopment. Work included subcontractor management and cost controls for these projects totaling \$8.8 million over a 3-year period.

Design/Build SVE Systems, Middlefield-Ellis-Whisman Superfund Site, Mountain View, CA. Managed the construction of the SVE systems at the former Fairchild facilities. Work included the installation of more than 100 air inlet, air extraction, and dual-purpose recovery wells, installation of more than 6,000 linear feet of aboveground and belowground piping and the installation of a SVE Skid containing 2-250 hp liquid ring pumps. Total project duration was 10-months at a cost of \$2.6 million project. The project was completed 18 months ahead of schedule which allowed the client to take advantage of favorable market conditions when selling the property.

Design/Build Regional Groundwater Remedial Construction-North and South, Middlefield-Ellis Whisman Superfund Site, Mountain View, CA. Managed the construction of the Regional Groundwater Remediation Project ("RGRP") groundwater treatment system installation. Work included the installation of 25 groundwater recovery wells, installation of more than 31,500 linear feet of double-contained and discharge piping, 55,000 linear feet of electrical conduit and installation of PLC based automation system. Work included complete Construction Management services for this multi-year, \$6.6 million project.

Design/Build Oyster Bay and West Winton Closed Landfill Facilities, Waste Management Inc., San Leandro, CA. Managed the design and construction of the leachate and landfill gas extraction and management systems for these sites under an order from the California Regional Water Quality Control Board and the Bay Area Air Quality Control District. Work included coordination of Point of Discharge with the San Leandro Waste Water Treatment Facility, installation of recovery wells, installation of 3,000 linear feet of leachate recovery and discharge piping, 12,000 linear feet of landfill gas collection pipeline, installation of a leachate pumping plant and landfill gas flare system including the installation of PLC-based automation system. Work included Design/Build Construction Management services for these 13-month, \$2.1-million-dollar projects. Due to the design/build and value engineering performed on this project the client saved over \$2.5 million dollars.

Design/Build Former Fairchild Semiconductor Brownfield Site Redevelopment, Mountain View, CA. Managed the design build and construction activities for modifications to the six groundwater treatment systems at the former Fairchild facilities during the site redevelopment. Work included destruction and reinstallation of 23 recovery wells and monitoring wells, installation of 18,000 linear feet of double contained piping and electrical conduits, installation of new PLC based automation systems, and modification of existing treatment system. Worked extensively with the site developer to coordinate the design and construction of the new facilities with the site environmental infrastructures. Performed Construction Management and developer coordination for this multi-year, \$9.8 million project.



Robert Ettinger
Senior Principal

Project Roles

- ▶ Technical Odor Monitoring & Mitigation

Specialties

- ▶ Vapor Intrusion Pathway Analysis
- ▶ Fate and Transport Modeling
- ▶ Risk-Based Corrective Action
- ▶ Human Health Risk Assessment
- ▶ Design of Soil Vapor Remediation Systems

Education

- ▶ BS, Chemical Engineering, Rice University, Houston, Texas, 1986
- ▶ MS, Chemical Engineering, University of California, Berkeley, 1989

Career Summary

Mr. Ettinger is an environmental specialist with over thirty years of experience, including research, development and direct technical support to gasoline retail and distribution, petroleum pipeline, petrochemical facilities, manufacturing locations, dry cleaner operations, and waste sites. Much of Mr. Ettinger's work has focused on fate and transport of contaminants in the unsaturated zone including vapor emission estimation, soil vapor extraction system design, and subsurface methane and contaminant vapor migration to indoor and outdoor air. He is also particularly experienced in human health risk assessment, litigation support, design and implementation of groundwater and soil vapor remediation systems, regulatory negotiation, and risk-based strategy development for environmental liability and business management.

Mr. Ettinger is co-author of the Johnson and Ettinger (1991) algorithm for evaluating subsurface contaminant vapor intrusion to indoor air and has conducted field investigations and modeling evaluations on this topic for over a decade. He has published numerous articles on chemical vapor intrusion, environmental fate of volatile chemicals, and design considerations for groundwater and soil vapor extraction systems.

Relevant Project Experience

Sitewide Odor Assessment Study, Huntington Beach, CA. Led a field investigation to assess potential odor emissions for remediation of a petroleum waste landfill. The investigation included in-situ and ex-situ soil vapor sampling for chemical and odor analysis. These data were interpreted using a three-dimensional data visualization model. Correlations between measured and modeled odor parameters and chemical composition of the soil vapor sampling were used to assess potential emissions to outdoor air during excavation activities and to identify areas of higher odor causing potential to aid in remedial action planning.

Gas Treatment Emissions Litigation Support, Goleta, CA. Provided litigation support to the State of California Lands Commission to assess potential odor and health effects related to hydrogen sulfide emissions from the onshore gas treatment facility associated with the decommissioning activities for an offshore oil and gas production facility. Site operation data for the gas production and treatment equipment were reviewed and an air dispersion model was developed to assess potential exposures to neighboring communities and businesses.

Soil and Groundwater Emissions Litigation Support, Kankakee, IL. A modeling analysis was conducted to assess potential exposures due to emissions from soil and groundwater for a gasoline pipeline release site. This work included an assessment of volatile organic compound evaporative emissions following the release, emissions during soil remediation, and volatilization due to household use of groundwater.

Community Outdoor Air Monitoring Study, Carson, CA. A community outdoor air sampling and analysis study was conducted to evaluate potential impacts of shallow subsurface crude oil contamination to outdoor air. Time integrated air samples were collected at multiple locations throughout a residential neighborhood. Multiple monitoring events were conducted to assess temporal trends. A statistical analysis performed using data collected during this study showed that the sub-surface petroleum impacts did not impact outdoor air quality.

Vapor Intrusion Pathway Mitigation Implementation, Oakland, CA. Provided vapor intrusion investigation, expedited mitigation, and risk assessment services for Caltrans property leased to a charter middle school. Through negotiations with local oversight agency (Alameda County Department of Health), developed a strategy to implement interim mitigation measures on an expected basis to facilitate school opening for the fall semester. Additionally, provided technical support at community and school board meetings.

California-Specific Vapor Intrusion Attenuation Factor Analysis, CA. Led a research project to support the recommendation for a screening level attenuation factor suitable for environmental conditions present in California. A database of environmental vapor intrusion investigation results was prepared and evaluated to assess empirical attenuation factors for Sites located in California. In addition to a statistical analysis of the attenuation factors that is commonly

Robert Ettinger

used to assess empirical data, the research team also implemented a reliability assessment to provide a screening attenuation factor that more effectively aligns with a risk-based decision-making process.

Regional Groundwater Plume Vapor Intrusion Assessment, Los Angeles County, CA. Developed a strategy to evaluate the potential vapor intrusion pathway from a regional groundwater plume for a USEPA Region 9 CERCLA site. In response to recommendations included in the USEPA five-year review for the site, Geosyntec developed a vapor intrusion assessment strategy consisting of (i) a desktop review of existing environmental data; (ii) prioritization of areas for additional data collection including groundwater, soil vapor, and indoor air sampling; and (iii) evaluation of the supplemental data to recommend follow-up actions.

Human Health Risk Assessment, Carson, CA. Developed a strategy and database tools to conduct a human health risk screening evaluation for a residential development constructed at a historical crude oil storage facility. Risk screening evaluations are prepared on a property-by-property basis and updated as new data are collected. The methods developed for this project provide a cost-effective approach to perform over 250 risk screening evaluations and can be combined with geographic information system (GIS) software to provide an assessment of the screening risk results across the entire site.

Redevelopment Human Health Risk Assessment, Fullerton, CA. Conducted a human health risk assessment for the redevelopment of site with residual hydrocarbon impacts related to former operations at a bulk and package motor oil distribution facility. The risk assessment quantitatively evaluated the impact of natural vadose-zone biodegradation of the petroleum hydrocarbons on the potential for vapor intrusion exposures. The results of the risk assessment were used to obtain acknowledgement from the state regulatory agency that the proposed property redevelopment could proceed.

Vapor Intrusion Pathway Analysis, Carson, CA. Developed a strategy to conduct a vapor intrusion pathway evaluation for a residential development constructed at a historical crude oil storage facility. A phased assessment strategy was developed to assess potential safety concerns (i.e., migration of methane to on-site structures), soil vapor investigation, and indoor air sampling. The assessment strategy was developed to identify locations that may warrant immediate or interim actions and collect data that may be used to distinguish detected compounds from background sources. A multiple linear regression analysis was conducted to evaluate the data and determined that the concentrations of volatile organic compounds detected in indoor air are indistinguishable from background levels.

Vapor Intrusion Assessment, Sacramento County, CA. Developed a strategy and implemented a field investigation to evaluate the potential vapor intrusion pathway for a USEPA Region 9 CERCLA site. USEPA required the assessment of the vapor intrusion pathway for on-site and off-site receptors at an aerospace complex in Sacramento County, California. An investigation consisted of grab samples with real-time analysis for trichloroethene (TCE) to evaluate whether expedited mitigation measures were warranted. Additionally, an indoor air sampling program was implemented to assess potential chronic exposures for on-site buildings and a soil vapor sampling program was prepared to assess the vapor intrusion pathway for off-site locations.

Tier 3 Vapor Intrusion Assessment, IL. Developed a strategy to streamline Tier 3 assessments for the vapor intrusion pathway under the Illinois EPA Tiered Approach to Corrective Action (TACO) program. Tier 3 soil gas and groundwater remediation objectives for petroleum compounds that would not require institutional controls for future land use were calculated and submitted to IEPA for review and approval.

Vapor Intrusion Biodegradation Modeling, Los Angeles, CA. Assessed vapor migration to indoor air from a groundwater source at Region 9 Superfund site, including evaluation of field data, quantification of natural attenuation in the vadose zone and presentation of results to USEPA and DTSC. This is the first site where USEPA and CalEPA/DTSC accepted the use of a biodegradation model to quantitatively evaluate the vapor intrusion pathway.

Vapor Intrusion Litigation Support, San Diego, CA. Provided expert litigation support for a case involving the migration of chlorinated solvents from an aerospace manufacturing facility. An evaluation of the potential vapor intrusion exposures to building occupants at school and residential properties located downgradient from the manufacturing facility was conducted. An expert report rebutting the plaintiffs' experts' opinions regarding the vapor intrusion pathway analysis was prepared and an assessment of the potential exposures and implementability of mitigation measures were provided.



Haley Schneider, PHD, EIT
Engineer

Project Roles

- ▶ Technical Odor Monitoring & Mitigation
- ▶ System Inspection Team

Specialties

- ▶ Environmental Field Investigations
- ▶ Porewater Passive Sampling
- ▶ Data Management, Visualization, and Technical Reporting

Education

- ▶ PhD Civil Engineering, Texas Tech University, Lubbock, Texas, 2018
- ▶ MS Civil Engineering, Texas Tech University, Lubbock, Texas, 2015
- ▶ BS Civil Engineering, Texas Tech University, Lubbock, Texas, 2013

Registration & Certifications

- ▶ Texas Engineer-In-Training, No. 64063
- ▶ 40-hour OSHA HAZWOPER 29 CFR 1920.120e
- ▶ 8-hour OSHA HAZWOPER Supervisor Training
- ▶ DOT Hazardous Materials Shipping

Career Summary

Haley A. Schneider, PhD, Engineer based in southern California, has worked on a variety of projects since joining Geosyntec in August 2018. Haley supports a variety of projects ranging from small retail sites to Superfund projects, for which her roles have included project management, data management and reporting, safety management, and field sampling of environmental media (groundwater, soil, soil vapor, and indoor air). Haley specializes in the development and use of passive samplers to characterize porewater in sediments and shallow aquifers.

Relevant Project Experience

County of Santa Barbara, Santa Barbara, CA. Haley worked with County staff to perform an evaluation of the landfill gas extraction system at the Santa Ynez Airport Closed Landfill. She assisted the inspection of system infrastructure, collection of field readings, and collection of laboratory samples from vapor extraction wells and vapor probes to evaluate methane concentrations and assess the need for continued operation of landfill gas extraction system.

Confidential Client, Burbank, CA. Haley investigated vapor intrusion pathways into commercial storefronts covering 50,000 square feet. Project tasks included identification of potential VI pathways, installation of sub-slab soil vapor probes, collection of indoor/ambient air and sub-slab soil vapor samples in select storefronts, and preparation of technical memoranda to reporting findings and mitigation recommendations for each building.

Confidential Client, Whittier, CA. Haley assisted in the compliance, field sampling, and reporting efforts associated with the redevelopment of a mixed commercial/residential property impacted by historical arsenic and lead contamination. Project tasks included review of dust monitoring data in compliance with SCAQMD regulations, soil sample collection, field screening of soil samples, assistance with review and management of large time-sensitive data sets, and assistance writing the final remedial action completion report that ultimately achieved NFA for the site.

Confidential Client, San Gabriel Valley, CA. Haley assisted in the assessment of vapor intrusion risk potential for a commercial property impacted by chlorinated solvents/VOCs. Project tasks included utility clearance, mapping floor plans, interviewing tenants regarding HVAC use and occupancy, installing sub-slab soil vapor probes, collecting indoor/ambient air and sub-slab soil vapor samples, and preparing a technical report of findings and mitigation recommendations.

Confidential Client, Van Nuys, CA. Haley assisted in the installation and sampling of soil vapor probes as part of a residential soil vapor survey at a site impacted with chlorinated solvents/VOCs. Project tasks included utility clearance, direct-push drill rig oversight, soil classification and logging, and collection of soil and soil vapor samples.

Confidential Client, Stanton, CA. Haley has supported field sampling and reporting efforts associated with the redevelopment of a commercial property impacted by organochlorine pesticides. Project tasks include utility clearance, soil sample collection, and assistance writing technical reports communicating results and next steps.

Confidential Client, Santa Barbara, CA. Haley has scheduled and performed well installation, well development, soil sampling, groundwater sampling, residential vapor intrusion monitoring, and vapor intrusion mitigation system maintenance at a site impacted with chlorinated solvents/VOCs. The site is actively under remediation using in-situ chemical oxidation (ISCO) injections of sodium permanganate in conjunction with enhanced in-situ bioremediation (EISB). Haley has supported groundwater investigations that have optimized effectiveness of the ISCO system, as well as groundwater performance monitoring of the influence and extent of EISB injections.

Confidential Client, San Gabriel Valley, CA. Haley has coordinated and staffed multiple groundwater monitoring events in the El Monte Operable Unit of the San Gabriel Valley Superfund Site, where groundwater is impacted by chlorinated solvents and 1,4-dioxane. Project tasks include groundwater sampling of Westbay® Multi-port and standard monitoring wells, contractor oversight, and access coordination for private properties.



Reese Wilson, EIT
Engineer

Project Roles

- ▶ System Inspection Team

Specialties

- ▶ Hydrogeology Field Investigations and Remediation
- ▶ Soil Vapor and Vapor Intrusion Surveys
- ▶ Hydraulic System Process Design

Education

- ▶ MS, Civil and Environmental Engineering, California Polytechnic State University, San Luis Obispo, CA, 2015
- ▶ BS, Environmental Engineering, California Polytechnic State University, San Luis Obispo, CA, 2015

Registration & Certifications

- ▶ California Engineer-In-Training No. 151044
- ▶ 40-hour OSHA HAZWOPER 29 CFR 1920.120e
- ▶ 8-hour OSHA HAZWOPER Refresher Course 29 CFR 1920.120e
- ▶ 8-hour OSHA HAZWOPER Supervisor Training
- ▶ DOT Hazardous Materials Shipping for Environmental Professionals 49 CFR 172.704

Career Summary

Mr. Wilson has worked on a variety of projects since joining Geosyntec in June 2016. His project experience includes soil, soil vapor, vapor intrusion, and groundwater investigation methodologies, as well as onsite well installation and development. Additionally, Mr. Wilson has been involved in the design and drafting of soil vapor extraction and groundwater extraction and conveyance systems. He is proficient in leading vapor intrusion investigations and supervision of groundwater monitoring sites. In addition, Mr. Wilson has worked on projects in southern California counties and helped prepare figures, tables and text for reports under the oversight of the U.S. EPA, Regional Water Quality Control Board (RWQCB), and local regulatory agencies. During his time at Mazzetti Inc., Mr. Wilson gained proficiency designing plumbing systems for healthcare facilities. Mr. Wilson has conducted multiple vapor intrusion surveys to evaluate whether a pathway exists for vapor emanating in the subsurface to impact indoor air in commercial and residential buildings.

Relevant Project Experience

Confidential Client, Burbank, CA. Mr. Wilson conducted an investigation of vapor intrusion pathways into commercial storefronts covering 50,000 square feet. Project tasks include mapping floor plans, interviewing tenants regarding HVAC use and occupancy, identifying potential VI pathways, and preparing technical memoranda of findings and mitigation recommendations for each building.

Confidential Client, Oxnard, CA. Mr. Wilson has conducted regular operations monitoring and maintenance of the soil vapor extraction system placed onsite where the groundwater and soil vapor is impacted by chlorinated solvents. Tasks include weekly operations monitoring to assess the effectiveness of the soil vapor extraction system onsite.

Confidential Client, San Fernando Valley, CA. Mr. Wilson has conducted multiple indoor, sub-slab, and crawlspace air sampling events in the Glendale Operable Unit, where soil vapor is impacted by chlorinated solvents. Project tasks include equipment coordination, sub-slab soil vapor probe installation and sampling, and crawlspace air sample collection.

Confidential Client, Los Angeles County, CA. Mr. Wilson has been involved in multiple field efforts for an extensive PCB Indoor Air Pilot Study and vapor intrusion study throughout Los Angeles County. Project tasks include field and equipment coordination, subcontractor supervision, and onsite monitoring of multiple Indoor Air sampling pumps over 12-hour periods.

Confidential Client, San Fernando Valley, CA. Mr. Wilson has conducted soil vapor probe sampling events in the Glendale Operable Unit, where soil vapor is impacted by chlorinated solvents. Project tasks include soil vapor probe and groundwater sampling, and surveyor oversight.

Confidential Client, Santa Maria, CA. Mr. Wilson has been involved in outdoor air screening activities for a time-sensitive project in Santa Maria, CA. Project tasks include extraction well installation supervision, temporary soil vapor probe installation, and soil gas sampling. Project was successfully mitigated after approximately one month of field efforts.

Confidential Client, San Gabriel Valley, CA. Mr. Wilson has conducted multiple groundwater well installation and monitoring events in the El Monte Operable Unit of the San Gabriel Valley Superfund Site, where groundwater is impacted by chlorinated solvents and 1,4-dioxane. Project tasks include groundwater well installation, well development, groundwater sampling of Westbay© Multi-port and standard monitoring wells, and surveyor oversight.

Confidential Client, East Point, GA. Mr. Wilson contributed to an onsite surface water and groundwater field investigation event utilizing peristaltic and submersible pumps.

Confidential Client, Ventura County, CA. Mr. Wilson conducted multiple surface water and groundwater sampling events

Reese Wilson, EIT

in Casitas Springs, Oak View, Meiners Oaks, and Ojai to investigate the potential impact of onsite wastewater treatment systems on local groundwater and drinking water sources. Project activities included accessing wells on private and public property, low flow purge and sampling, and surface water quantification and sampling.

Confidential Client, northern Santa Clarita Valley, CA. Mr. Wilson has performed onsite groundwater field investigations including sampling for background analysis of water quality at a site adjacent to the Santa Clarita River, in the northern region of the Santa Clarita Valley. Investigation techniques include surface water sampling and low flow groundwater purge and sampling.

Confidential Client, Morgan Hill, CA. Mr. Wilson contributed to instrumentation selection, spatial coordination and design of well vaults using AutoCAD Civil 3D, and drafting of site plans, pipe profiles, and mechanical details.

Confidential Client, Hagerstown, MD. Mr. Wilson has performed design calculations for hydraulic loading, pipe structural stability, pump sizing, and calculation package report preparation. Other project tasks include instrumentation selection, spatial coordination within well vaults using AutoCAD Civil 3D, and drafting of site plans, pipe profiles, and mechanical details.

Confidential Client, Pensacola, FL. Mr. Wilson has contributed to hydraulic modeling and system sizing of a groundwater extraction system using WaterGEMS. Other project tasks include take-off quantity estimation, process and instrumentation design, custom well seal design, and calculation package report preparation.

Confidential Client, Piketon, OH. Mr. Wilson has contributed to report preparation and hydraulic loading design review for a low-level radioactive landfill leachate collection system.

Confidential Client, Puente Valley, CA. Mr. Wilson has contributed to permitting and design requirements for groundwater extraction wells within the Puente Valley Operable Unit.



John Conroy, EIT
Engineer

Project Roles

- ▶ System Inspection Team

Specialties

- ▶ Soil Vapor Investigation
- ▶ Indoor Air Sampling
- ▶ Soil Sampling
- ▶ Site Investigation and Remediation
- ▶ System Operation, Optimization, and Maintenance
- ▶ Compliance Monitoring

Education

- ▶ MS, Geological Engineering, Missouri University of Science and Technology, Rolla, Missouri, 2012
- ▶ BS, Environmental Engineering, Missouri University of Science and Technology, Rolla, Missouri, 2010

Registration & Certifications

- ▶ California Engineer in Training No. 1740953
- ▶ 40-hour OSHA HAZWOPER 29 CFR 1920.120e
- ▶ 8-hour OSHA HAZWOPER Refresher Course 29 CFR 1920.120e
- ▶ 8-hour OSHA HAZWOPER Supervisor Training
- ▶ DOT Hazardous Materials Shipping for Environmental Professionals 49 CFR 172.704
- ▶ American Red Cross First Aid Training
- ▶ American Heart Association Adult/Child/Infant CPR Training

Career Summary

Mr. Conroy has eight years of experience in the environmental investigation and remediation industry. His experience includes site investigation and remediation, soil vapor investigation, treatment system operation and maintenance, compliance monitoring, and indoor air sampling. His field experience includes site assessment, soil vapor extraction and monitoring well installation, remediation system pilot testing, soil vapor sampling, indoor air and outdoor air sampling. His remediation experience includes design, permitting, implementation, operation/maintenance and optimization of remediation systems including soil vapor extraction (SVE) systems, groundwater pump and treat systems, thermal oxidation systems, and soil vapor and groundwater carbon filtration systems. Mr. Conroy has worked on projects in numerous California counties under the regulatory oversight of the United States Environmental Protection Agency (USEPA), Department of Toxic Substances Control (DTSC), Regional Water Quality Control Board (RWQCB), and local regulatory agencies.

Relevant Project Experience

Quarterly Compliance Monitoring, Confidential Client, El Monte, California. Managed and conducted compliance monitoring field activities for several compliance monitoring projects at sites impacted by chlorinated solvents, petroleum hydrocarbons, heavy metals, etc.

SVE System Pilot Testing, Design, Construction and Operation, Confidential Client, Van Nuys, CA. Coordinated and conducted soil vapor extraction (SVE) well installation, SVE pilot testing, full-scale system design, permitting, construction, startup, operation and monitoring.

Residential and Commercial Methane Leak Mitigation via Thermal Oxidation, Confidential Client, Santa Maria, CA. Conducted the mitigation and monitoring of a residential and commercial gas leak by using a temporary SVE/Thermal Oxidation system.

SVE Sub-slab Depressurization Diagnostic Test, Confidential Client, Santa Barbara, CA. Coordinated and conducted sub-slab depressurization system installation and diagnostic testing. Diagnostic testing activities were conducted to evaluate the viability of SVE as a remedial technology to reduce the potential for vapor intrusion into on-site buildings.

Radon Mitigation System Installation and Testing, Confidential Client, Goleta, CA. Coordinated and conducted the installation and testing of a radon mitigation system.

Confidential Client, Van Nuys, CA. Coordinated and conducted indoor air and outdoor air sampling in accordance with CA DTSC methodology. Completed a building chemical survey/screening event, a cross-slab pressure measurement event and a HVAC system assessment. Sampling activities were conducted to determine the potential for vapor intrusion.

Confidential Client, City of Industry, CA. Conducted indoor air and outdoor air sampling in accordance with CA DTSC methodology. Completed a building chemical survey/screening event. Sampling activities were conducted to determine the potential for vapor intrusion into off-site buildings.

Confidential Client, Santa Maria, CA. Coordinated and conducted soil stockpile sampling and certification in accordance with CA DTSC methodology.

San Gabriel Valley Super Fund Site, Confidential Client, El Monte, CA. Conducted permitting, cost estimating, well installation, well development, aquifer testing, groundwater sampling of Westbay© multi-port and standard monitoring wells, surveyor oversight, waste profile sampling, data analysis, reporting and geotechnical evaluations.

John Conroy, EIT

SVE OM&M, Confidential Client, Oxnard, CA. Conducts regular operation and maintenance of a soil vapor extraction (SVE) system and Dual-Phase extraction (DPE) system with GAC filter media at a soil vapor and groundwater remedial investigation site. The site is a commercial property under the regulatory oversight of RWQCB with chlorinated solvent groundwater impacts extending to off-site locations.

Confidential Client, Ventura, CA. Conducted a soil and groundwater investigation using membrane interface probe (MIP) technology and installed groundwater monitoring wells. Investigative activities were conducted to identify site data gaps and support initial evaluation of in situ bioremediation as a potential site remedy.

SVE Pilot Test, Confidential Client, Santa Maria and Santa Barbara, CA. Coordinated and conducted SVE well installation, SVE pilot testing and groundwater monitoring and sampling events. Pilot testing activities were conducted to evaluate the viability of SVE as a remedial technology to reduce source-zone impacted soils beneath the site.

SVE System Operation, Confidential Client, Santa Maria, CA. Coordinated and conducted SVE system installation, startup, permitting, operation and monitoring.

Direct Domestic Use of Extremely Impaired Sources Permitting, San Gabriel Valley Super Fund Site, Confidential Client El Monte, CA. Coordinated and conducted source water and raw water quality characterization and Identified source protection monitoring and treatment.

Aquifer Testing, Confidential Clients, El Monte, CA. Conducted pump tests on eight groundwater extraction wells. Flow rates ranged from 30 to 350 gpm. Data was collected with InSitu pressure transducers and analyzed with AQTESOLV® computer software.

Drilling and Soil Logging, Confidential Clients, El Monte, Van Nuys, Ventura, Santa Barbara, CA. Experience in multiple drilling technologies includes hollow stem auger, mud rotary, air rotary, direct push, and sonic core drilling. Field sampling experience includes soils sampling using brass sleeves and EnCore® subsampling device according to EPA method 5035.

Soil Vapor Sampling, Confidential Client, Van Nuys, Santa Barbara, CA. Coordinated and conducted the installation and sampling of numerous soil vapor probes in accordance with CA DTSC methodology. This work was performed under RWQCB oversight as part of a larger investigation to delineate the site-derived VOC and metals impacts to soil, soil vapor, and groundwater.

Soil Vapor Sampling and Rebound Testing, Confidential Client, Oxnard, CA. Coordinated and conducted the installation and sampling of numerous soil vapor probes in accordance with CA DTSC methodology. Rebound testing was conducted to establish the endpoint criteria for active remedial action.

Radon Mitigation System Installation and Testing, Confidential Client, Goleta, CA. Coordinated and conducted the installation and testing of a radon mitigation system.



Baird King, PG
Project Geologist

Project Roles

- ▶ Odor Monitoring Field Team

Specialties

- ▶ Site Assessment
- ▶ Long-Term Monitoring
- ▶ Soil and Groundwater
- ▶ Vapor Intrusion Mitigation
- ▶ Soil and Groundwater Remediation
- ▶ Dust Mitigation
- ▶ Natural Occurring Asbestos

Education

- ▶ MS, Geosciences, University of California, Riverside, Riverside, CA, 2010
- ▶ BA, Geosciences, State University of New York, Geneseo, Geneseo, NY 2007

Registration & Certifications

- ▶ California Professional Geologist #9638
- ▶ Hazardous Waste Operations and Emergency Response (HAZWOPER) 40-hr, OSHA
- ▶ 8-hour HAZWOPER Supervisor, OSHA
- ▶ CPR and First Aid Certified, Red Cross

Career Summary

Mr. King joined Geosyntec in 2016 with three years of experience in environmental remediation, hydrogeologic investigation and risk assessment. He has led and participated in all phases of soil and groundwater remediation and vapor intrusion mitigation from proposal writing to field work to reporting, with a strong focus on hydrocarbon and chlorinated solvent contamination. He has analyzed available geologic and environmental resources to develop work plans, implement investigative and remedial action and, upon completion, prepare follow-up reports for submission to regulatory agencies. At locations where vapor intrusion poses a critical risk to residents, he has overseen the installation, and conducted the testing of sub slab depressurization vapor mitigation systems. With his previous employer, Mr. King participated in and managed multiple soil and groundwater remediation efforts throughout Santa Barbara, Ventura and Kern counties, California, and Northern Germany. He also conducted a construction risk management investigation for the US Army Corps of Engineers in Kaiserslautern, Germany for a hospital servicing three military bases.

Relevant Project Experience

Confidential project, confidential client, Catalina Island, CA. Managed team of 18 personnel during implementation of dust management plan (DMP) during a three-year remote construction project occurring in an area with natural occurring asbestos (NOA). Team responsible for daily fence-line dust monitoring and inspection and documentation of DMP procedures implemented by construction contractor. Conducted pre-construction sampling and delineation of NOA in development of the DMP.

Kast, Shell, City of Carson/Los Angeles County, CA. Assistant Project Manager responsible for sub-slab depressurization (SSD) design, installation and testing at a superfund site consisting of 283 single-family residences. Oversees team of 10+ field staff during this 10+ year project.

Mission Ambassador, Mission Linens, City of Santa Barbara, Santa Barbara County, CA. Project manager responsible for all aspects of project implementation including semi-annual and annual vapor intrusion monitoring, design and implementation of a sub-slab depressurization (SSD) vapor intrusion mitigation system (VIMS), design and implementation of a soil vapor extraction (SVE) system, and regular operations, monitoring and maintenance (OM&M) of the systems.

Confidential Project, Confidential Client, City of Vernon/Los Angeles County, CA. Field lead and on-site P.G. responsible for leading team of 20+ subcontractors in a high-profile assessment of ADL, other metal, and volatile organic compound (VOC) contaminated soil. Maintained strict health and safety, sampling, and recording protocol under consistent regulatory oversight. Work was conducted in level C PPE with strict decontamination procedures and included the drilling and sampling of 20+ boreholes using hollow stem auger, cone penetration test and direct push technologies. Contributed to subsequent reporting efforts.

Arden Drive Properties, ESPSDs, City of El Monte/Los Angeles County, CA. In charge of planning and implementation of a large site assessment of chlorinated VOC and metal contamination in soil, soil vapor and groundwater including the drilling of 70 boreholes using hollow stem auger and direct push technology.

El Monte Operable Unit, ESPSDs, City of El Monte/Los Angeles County, CA. Managed planning, execution and reporting efforts including installation of groundwater monitoring wells using sonic and hollow stem auger methodologies, and soil and groundwater sampling; analyzed site data to resolve issues related to groundwater flow, contaminant source and contaminant migration; prepared reports for submission to the regulatory agencies on behalf of the client.

Baird King, PG

Monogram Aerospace Fasteners, Monogram Aerospace Fasteners, City of Commerce/Los Angeles County, CA. Project manager in charge of all phases of vapor intrusion assessment and remediation related to VOC contamination.

Mission Ambassador, Mission Linens, Santa Barbara, CA. Responsible for coordinating and implementing field investigations involving soil vapor probe installation, soil vapor, indoor air and crawl space data collection, and follow up reporting.

Kast, Shell, City of Carson/Los Angeles County, CA. Design assistance, oversight of installation, and startup testing of sub-slab depressurization systems at a superfund site involving 283 homes.

Confidential Project, Confidential Client, MS. Oversaw the application of Retro-Coat™ floor coating to assist with vapor intrusion mitigation at a factory where a sub-slab depressurization system was ineffective at maintaining indoor air concentrations below regulatory levels.

Memorial Hills, Memorial Hills Apartments, Houston, TX. Installation oversight and startup testing of a large, 11 suction point SSD system in a multi-story apartment complex.

Glendale Operable Unit, GRG, City of Glendale/Los Angeles County, CA. Organized and managed indoor air, crawl space, and sub slab sampling at 30 homes as well as the installation and sampling of soil vapor probes.

Benchmark, Northrop Grumman, City of Industry/Los Angeles County, CA. Organized and managed indoor air and crawl space sampling at 14 homes and the sampling of 45 soil vapor probes.

Broadway Plaza, Broadway Plaza Dry Cleaners, Santa Maria/Santa Barbara County, CA. Conduct operations, monitoring and maintenance (OM&M) of Geosyntec's on-site soil vapor extraction system.

Confidential project, confidential client, Catalina Island, CA. Pre-construction sampling and delineation of natural occurring asbestos at a large construction site to assist in development of a dust management plan for the project.

Confidential project, Confidential client, Catalina Island, CA. Responsible for on-going dust monitoring, oversight of dust mitigation plan implementation and management of eight rotating field staff.

El Monte Operable Unit, ESPSDs, City of El Monte/Los Angeles County, CA. Prepared budgets; coordinated and conducted field work including the installation of groundwater monitoring wells using sonic and hollow stem auger methodologies, and soil and groundwater sampling; analyzed site data to resolve issues related to groundwater flow, contaminant source and contaminant migration; prepared reports for submission to the regulatory agencies on behalf of the client.

Former Litton Data Systems Facility, Northrop Grumman, City of Van Nuys/Los Angeles County, CA. Coordinated and conducted field work including the installation of deep groundwater monitoring wells using sonic drilling methodology.

Edwards Air Force Base Retail Stations, U.S. Air Force, Edwards Air Force Base, Los Angeles County, CA. Lead field geologist responsible for overseeing the installation of 24 air sparge (AS) and dual phase extraction (DPE) wells as well as the subsequent AS/DPE pilot test. Helped author the follow-up Site Assessment Report.

Bakersfield Refinery, Shell Oil, City of Bakersfield/Kern County, CA. Performed field oversight of the installation of multiple shallow and deep groundwater monitoring wells using mud rotary and hollow stem auger drilling methodologies. Performed field oversight of the installation of multiple soil vapor probes using hollow stem auger methodology and conducted follow-up soil vapor sampling.

Retail Gas Stations, Shell Oil, Multiple retail stations throughout Northern Germany and Santa Barbara and Ventura Counties, CA. Coordinated and performed field oversight of multiple groundwater monitoring well installation and destruction events at multiple petroleum retail locations. Oversaw multiple air sparge/dual phase extraction events.

Gaviota Terminal, Shell Oil, Gaviota/Santa Barbara County, CA. Oversaw the implementation of a land farming pilot study.



Kenjo Agustsson, PG
Project Geologist

Project Roles

- ▶ Odor Monitoring Field Team

Specialties

- ▶ Soil Vapor and Indoor Air Sampling
- ▶ Vapor intrusion investigations and remediation
- ▶ Hydrogeology Field Investigations and Remediation

Education

- ▶ MS, Geological Sciences, emphasis in metamorphic petrology, University of Nevada, Reno, 2014
- ▶ BS, Earth Sciences, Geology minor, California Polytechnic State University, San Luis Obispo, 2011

Registration & Certifications

- ▶ California Professional Geologist, No. 9555

Career Summary

Mr. Agustsson has worked on a variety of projects since joining Geosyntec in March 2015. His project experience includes soil, soil vapor, and groundwater investigation methodologies, including onsite well installation and development. He is proficient in field supervision of groundwater monitoring sites. In addition, Mr. Agustsson has worked on projects in southern California counties and helped prepare figures, tables and text for reports under the oversight of the U.S. EPA, Regional Water Quality Control Board (RWQCB), and local regulatory agencies. Mr. Agustsson has conducted multiple vapor intrusion surveys to evaluate whether a pathway exists for vapor emanating in the subsurface to impact indoor air in commercial buildings. Mr. Agustsson has conducted multiple soil vapor surveys at sites throughout southern California. These soil vapor surveys have included use of both temporary and permanent soil vapor wells installed and sampled for the purpose of obtaining data to assess the risk to human health. Mr. Agustsson has conducted multiple fugitive dust and air surveys in compliance with local regulatory agencies and permits. Mr. Agustsson has conducted multiple vapor intrusion and indoor air surveys to evaluate whether a pathway exists for vapor emanating in the subsurface to impact indoor air in commercial buildings. Mr. Agustsson has conducted multiple soil vapor surveys at sites throughout southern California. These soil vapor surveys have included use of temporary and permanent soil vapor wells and sub-slab soil vapor probes installed and sampled for the purpose of obtaining data to assess the risk to human health.

Relevant Project Experience

Exide Technologies, Vernon, CA. Mr. Agustsson was the project manager and performed and led the workplan and field effort, under the direct supervision of DTSC, as on-site geologist and safety manager at this site impacted with lead, arsenic, and VOCs. This project involved supervising multiple contractors and site personnel. Site activities included soil sample collection and logging in Level C PPE, dust control plan monitoring, oversight of drilling operations: Cone Penetration Testing, roto-sonic and direct-push drilling. Dust control monitoring was conducted in compliance with the on-site federal Clean Air Act Title V permit.

Confidential Client, Southern California, CA. Mr. Agustsson has been involved in multiple field efforts for indoor air quality monitoring of K-12 school facilities in support of a human-health risk assessment study in response to local wildfires. Project tasks include field and equipment coordination, subcontractor supervision, and onsite indoor monitoring.

Confidential Client, Los Angeles, CA. Mr. Agustsson has conducted multiple soil sampling projects in support of site upgrades in compliance with the American Disabilities Act Rule 1466 to minimize off-site fugitive dust emissions. Shallow soil borings were logged and sampled via hand auger following specific and differing client sampling instructions and requests.

Confidential Client, Santa Maria, CA. Mr. Agustsson has been involved in outdoor air screening activities for a time-sensitive project in Santa Maria, CA. Project tasks include extraction well installation supervision and soil gas sampling. Project was successfully mitigated after approximately one month of field efforts.

Confidential Client, Southern California. Mr. Agustsson has been involved in outdoor air sampling activities for a time-sensitive and high-profile project in southern California. Project tasks include supervision of deployment and collection of outdoor air sampling canisters as well as monitoring high-volume air sampling equipment.

Confidential Client, Oxnard, CA. Mr. Agustsson has conducted regular operations monitoring and maintenance of the soil vapor extraction system placed onsite where the groundwater and soil vapor is impacted by chlorinated solvents. Tasks include weekly operations monitoring to assess the effectiveness of the soil vapor extraction system onsite.

Confidential Client, Los Angeles County, CA. Mr. Agustsson has been involved in multiple field efforts for an extensive PCB Indoor Air Pilot Study and vapor intrusion study throughout Los Angeles County. Project tasks include field

Kenjo Agustsson, PG

and equipment coordination, subcontractor supervision, and onsite monitoring of multiple Indoor Air sampling pumps over 12-hour periods.

Confidential Client, Pacific Palisades, CA. Mr. Agustsson has conducted soil vapor probe installation and indoor air sampling at a residence in the vicinity of a former dry cleaners site in Pacific Palisades, where soil vapor is potentially impacted by chlorinated solvents. Project tasks include **hand auger and installation of three soil vapor probes and deployment and collection of 12-hour summa canisters.**

Former Tecknit and Tube Holding Company, Santa Barbara, CA. Mr. Agustsson is a project manager and an experienced field manager at a site impacted with chlorinated solvents. Mr. Agustsson has scheduled and performed indoor air and soil vapor field investigations. The groundwater at the site is actively being remediated with in-situ chemical oxidation (ISCO) via sodium permanganate injections and enhanced in-situ bioremediation (EISB). Mr. Agustsson has conducted and managed quarterly indoor air and groundwater investigations in compliance with RWQCB directives.

Confidential Client, Santa Maria, CA. Mr. Agustsson has conducted soil vapor probe and soil vapor extraction well installation as well as multiple soil vapor probe sampling events at a former dry cleaners site in Santa Maria, where soil vapor is impacted by chlorinated solvents. Project tasks include temporary and permanent well installation via hollow stem auger and direct push drilling, soil and soil vapor probe sampling, and surveyor oversight. Mr. Agustsson has prepared reports for soil and soil vapor probe-sampling events. In addition to the aforementioned-work, Mr. Agustsson has conducted regular operations monitoring and maintenance of the soil vapor extraction system placed onsite.

Confidential Client, Inyo County, CA. Mr. Agustsson is a project manager for and has conducted soil vapor installation and monitoring events in Inyo County, CA where groundwater is potentially impacted by arsenic. Project tasks include soil vapor probe installation and quarterly sampling under the direction of the RWQCB.

Confidential Client, Whittier, CA. Mr. Agustsson has conducted soil vapor installation and sampling in an effort to support housing redevelopment at the site, where the soil is impacted by metals and potentially VOCs. Site activities include soil vapor sampling around former underground storage tank and sump locations to investigate the potential for vapor intrusion at the future site of housing under the direct oversight of the DTSC.

Northrop Grumman, Van Nuys, CA. Mr. Agustsson is a project manager and has performed driller oversight and soil vapor sampling in compliance with RWQCB orders, where groundwater is impacted by chlorinated solvents. Project tasks include soil vapor probe sampling, drilling oversight, and surveyor oversight. Additional project tasks include report preparation for the groundwater monitoring and soil vapor monitoring program for the site under RWQCB oversight.



Steven Thorp
Staff Scientist

Project Roles

- ▶ Odor Monitoring Field Team

Specialties

- ▶ Hydrogeologic Sampling and Remediation
- ▶ Soil Vapor and Vapor Intrusion Investigation
- ▶ Air Monitoring and Stormwater Intrusion Inspections

Education

- ▶ MS, Environmental Geology, Soil & Groundwater Emphasis, California State University, San Bernardino, 2019
- ▶ BS, Environmental Sciences, Environmental Organic Chemistry emphasis, California Baptist University, 2017

Career Summary

Mr. Thorp has 2.5 years of experience in the environmental investigation and remediation industry. His expertise includes soil, soil vapor, and groundwater investigation methodologies, risk assessment, and subcontractor oversight. He is proficient in sampling for soil, soil vapor, and groundwater, remote field assignments, and geochemical data modeling and interpretation. In addition, Mr. Thorp is an active member of the Geosyntec vapor intrusion practice team, knowledgeable on sampling protocols, and data analysis. He has worked on several projects in southern California counties and assisted with the preparation of reports under the oversight of the U.S. EPA, the Department of Toxic Substances Control (DTSC), Regional Water Quality Control Board (RWQCB), Air Quality Management District (AQMD), and local regulatory agencies. Mr. Thorp is also experienced with providing construction oversight services at several sites throughout southern California.

Mr. Thorp has participated in numerous soil vapor surveys at sites throughout southern California with many culminating in vapor mitigation technology applications. These soil vapor surveys have included use of both temporary and permanent soil vapor wells installed and sampled for the purpose of obtaining data to assess the risk to human health.

Relevant Project Experience

Remedial Investigation and Implementation, Confidential Client, Van Nuys, CA. Mr. Thorp performed soil vapor sampling in accordance with DTSC guidelines. He also performed a soil vapor extraction (SVE) step test to determine the effectiveness of SVE at the site, performed operations maintenance and monitoring (OM&M) of said SVE system, and oversaw subcontractor activities onsite. He has also provided soil sampling, driller oversight, and subcontractor coordination for subsequent investigation phases.

Vapor Intrusion Investigation, Confidential Client, Canoga Park, CA. Mr. Thorp performed sub-slab soil vapor probe installation and subsequent air and sub-slab soil vapor sampling at a former defense contractor site in Canoga Park.

Groundwater Investigation, Confidential Client, San Gabriel Valley, CA. Mr. Thorp has performed field operations in the El Monte Operable Unit of the San Gabriel Valley Superfund Site, where groundwater is impacted by chlorinated solvents and 1,4-dioxane. Project tasks included hollow-stem/mud rotary well installation oversight, well development, groundwater sampling of Westbay© Multi-port and standard monitoring wells, aquifer testing, soil vapor probe installation and sampling, soil sampling, and waste profiling.

Site Assessment and Remediation, ASCON Landfill, Huntington Beach, CA. Mr. Thorp has provided continual support to this Superfund site. The project consists of soil, groundwater, and air monitoring and remediation of the 38 acres of a petroleum industry landfill. Steven has provided data management and reporting for the project.

Santa Barbara Commercial VI, Confidential Client, Santa Barbara, CA. Mr. Thorp oversaw the construction and subsequent testing of an SVE and sub-slab depressurization (SSD) system at a commercial VI site in Santa Barbara. Steven provided construction and excavation oversight, subcontractor coordination and scheduling, system sampling and monitoring, soil vapor probe installation and sampling, soil sampling, and continual system OM&M to ensure adherence to AQMD permit guidelines.

Catalina NOA Dust Mitigation, Confidential Client, Catalina Island, CA. Mr. Thorp provided continual support to this confidential client project. The project consisted of overseeing dust mitigation of soils containing naturally occurring asbestos (NOA) at a construction project on Catalina Island. Duties included inspection of best management practices (BMPs) implemented by construction contractors and monitoring fugitive dust to maintain AQMD compliance onsite.

RCRA Facility Investigation, Confidential Client, Vernon, CA. Mr. Thorp assisted with the RCRA facility investigation (RFI) of a former lead battery recycling plant in Vernon. Steven provided field work in the form of soil sampling, logging, subcontractor oversight, air monitoring, and sampling area decontamination and setup.

Steven Thorp

Construction Oversight, Confidential Client, Whittier, CA. Mr. Thorp is responsible for oversight of construction activities taking place near a soil consolidation liner containing arsenic and lead contaminated soils. His roles include oversight of excavation activities during the installation of onsite utilities to ensure the soil consolidation liner was not damaged and inspection of soil liner integrity throughout the course of the construction activities, as well as soil sampling of excavated materials.

VI Investigation, Confidential Client, Oxnard, CA. Mr. Thorp oversaw soil vapor probe (SVP) well placement and conducted a subsequent abandoned oil well inspection in accordance with the California Division of Oil, Gas, and Geothermal Resources (DOGGR). His roles included subcontractor oversight during SVP placement, GW sampling, and the excavation of abandoned oil wells within both active and inactive agricultural fields alongside DOGGR agents.

Stormwater Intrusion Management Plan Inspections, Confidential Client, Multiple sites, CA. Mr. Thorp has provided continued oversight of Stormwater Intrusion Management Plan (SIMP) inspections at various natural gas and oil drilling/storage sites throughout Southern California. His role includes regular inspections of drill crew adherence to, and provided consultation on, compliance practices established in SIMP guidelines.



Anabelle Kline
Senior Staff Scientist

Project Roles

- ▶ Odor Monitoring Field Team

Specialties

- ▶ Environmental Field Investigations
- ▶ Data Management, Visualization, and Technical Reporting

Education

- ▶ MS, Geology, emphasis on hydrothermal ore deposits, Auburn University, 2019
- ▶ BS, Geology, Auburn University, 2017

Career Summary

Ms. Kline has worked on a variety of projects since joining Geosyntec in August 2019. Her project experience includes soil, soil vapor, vapor intrusion, and groundwater investigation methodologies, including onsite well installation and development. She is proficient in field supervision of groundwater monitoring sites. In addition, Ms. Kline has worked on projects in southern California counties and helped prepare reports under the oversight of the U.S. EPA, Department of Toxic Substances Control (DTSC), Regional Water Quality Control Board (RWQCB), and local regulatory agencies. Ms. Kline has conducted multiple soil vapor surveys at sites in southern California. These soil vapor surveys have included use of both temporary and permanent soil vapor wells installed and sampled for the purpose of obtaining data to assess the risk to human health.

Relevant Project Experience

Northrop Grumman, Van Nuys, CA. Ms. Kline has coordinated and conducted multiple soil vapor sampling events where soil vapor is impacted by chlorinated solvents. Ms. Kline has also conducted regular operations monitoring and maintenance of the soil vapor extraction system placed onsite. Project tasks include soil vapor probe sampling, SVE system pilot testing, weekly SVE system operations monitoring, and monthly vacuum response monitoring. Ms. Kline has also prepared report drafts documenting site operations under SCAQMD and LARWQCB oversight.

Confidential Client, Oxnard, CA. Ms. Kline has conducted regular operations monitoring and maintenance of the soil vapor extraction system placed onsite where the groundwater and soil vapor is impacted by chlorinated solvents. Tasks include weekly operations monitoring to assess the effectiveness of the soil vapor extraction system onsite. She coordinated and conducted multiple annual sub slab probe sampling events.

Confidential Client, San Gabriel Valley, CA. Ms. Kline assisted with the installation of multi-nested soil vapor probes using hollow stem auger drilling to evaluate lateral diffusion gradients from shallow sources of volatile organic compounds, and the relationship between shallow soil vapor concentrations and underlying groundwater concentrations. Tasks include driller oversight, soil classification and sampling, groundwater sampling, and follow up sampling of the soil vapor probes.

Mission Ambassador, Mission Linens, Santa Barbara, CA. Ms. Kline has coordinated and conducted multiple field investigations to evaluate current VI risk from residual chlorinated volatile organic compound impacts in the Site subsurface. Tasks include soil vapor probe installation, soil vapor sampling, indoor air and crawl space sampling and follow up reporting tasks.

Confidential Client, Ontario, CA. Ms. Kline has performed soil vapor sampling at an active metals manufacturing facility with an existing SVE system, where a release of volatile organic compounds has occurred to the subsurface associated with historical manufacturing operations. Tasks include sampling of the existing network of sub-slab probes, deeper soil vapor probes, and dual nested soil vapor probes.

Confidential Client, Goleta, CA. Ms. Kline has conducted soil vapor probe and soil vapor extraction well installation associated with the redevelopment of a mixed commercial/residential property. Project tasks include installation of temporary soil vapor probes via direct push drilling. Tasks include surveyor oversight, driller oversight, soil, and soil vapor probe sampling.

Confidential Client, San Fernando Valley, CA. Ms. Kline has assisted with semiannual soil vapor sampling and accelerated response to an exceedance of the DTSC ARAL of TCE at a commercial property associated with an ongoing vapor intrusion investigation from a site impacted with chlorinated solvents/VOCs including tetrachloroethene and trichloroethene. Project tasks include the collection of soil gas, identification of potential VI pathways, cleaning and sealing of concrete slab joints using flowable sealant, and collection of confirmation samples of indoor air.

Confidential Client, Stanton, CA. Ms. Kline has performed sampling of soil vapor probes at a Brownfield site redeveloped for a residential land use.

Anabelle Kline

Confidential Client, Gardena, CA. Ms. Kline has assisted with the installation and sampling of a sub slab probe at an automotive center within the Los Angeles Basin to assess the lateral and vertical extent of total petroleum hydrocarbons (TPH) and volatile organic compounds (VOCs) in soil.

Confidential Client, Santa Barbara, CA. Ms. Kline has helped lead a field event to address increased concentrations of VOCs in soil vapor and groundwater following shutdown of the former SVE system at a former dry cleaner. Tasks include sampling of existing soil vapor probes, sub-slab probes, SVE wells, and indoor air along with radon grab sampling and RAD7 sampling.

Former Tecknit and Tube Holding Company, Santa Barbara, CA. Ms. Kline has performed sub slab probe installation and sampling investigations, as well as indoor air and crawl space vapor sampling.

Confidential Client, Los Angeles, CA. Ms. Kline has been involved in multiple turf sampling projects to sample components of artificial turf to determine waste characteristics prior to replacing artificial turf athletic fields. Project tasks include sampling the various turf components following specific sampling protocols.

Confidential Client, San Gabriel Valley, CA. Ms. Kline has coordinated and staffed multiple groundwater monitoring events in the El Monte Operable Unit of the San Gabriel Valley Superfund Site, where groundwater is impacted by chlorinated solvents and 1,4-dioxane. Project tasks include groundwater sampling of Westbay© Multi-port and standard monitoring wells, contractor oversight, and access coordination for private properties. In addition to field investigations, Ms. Kline has assisted with preparation of the quarterly and annual groundwater monitoring program report for the site under RWQCB oversight.

Confidential Client, Whittier, CA. Ms. Kline has provided oversight of the implementation of a soil management plan at a Brownfield site subject to redevelopment for a commercial land use. Oversight included ensuring processes and procedures outlined in the SMP were followed by the client's subcontractors. Ms. Kline has also conducted a confirmation sampling event of soil to support housing redevelopment at the site. Site activities include groundwater sampling for arsenic and lead to investigate the potential impact of surface metals concentration on the water table under the oversight of the DTSC.

Northrop Grumman, Van Nuys, CA. Ms. Kline has been involved in driller oversight for this site, where groundwater is impacted by chlorinated solvents. Project tasks include mud-rotary drilling, air rotary casing hammer drilling, sonic drilling, soil classification, soil sampling, groundwater sampling, well development, oversight of IDW disposal, and preparation of the annual groundwater monitoring program report for the site under RWQCB oversight. Project challenges include managing limited space for site activities and communicating with challenging neighboring businesses.

Confidential Client, Oxnard, CA. Ms. Kline has coordinated and conducted multiple groundwater sampling events using passive diffusion samplers and assisted with AOPC soil removal and decommissioning of the soil vapor extraction system.

Northrop Grumman, Woodland Hills, CA. Ms. Kline has helped manage the annual groundwater investigations for this site assessing chlorinated solvents associated with site activities and gasoline additives associated with off-site activities. She has prepared report drafts for the annual groundwater monitoring program report for the site under RWQCB oversight.

Former Tecknit and Tube Holding Company, Santa Barbara, CA. Ms. Kline has performed onsite groundwater field investigations of chlorinated solvents. The site is actively being remediated with in-situ chemical oxidation (ISCO) via sodium permanganate injections and enhance in-situ bioremediation (EISB).

Confidential Client, Inyo County, CA. Ms. Kline has conducted groundwater monitoring events at a site in Inyo County, CA where groundwater is impacted by arsenic and other metals. Project tasks include composite sampling setup and collection of wastewater, quarterly groundwater sampling events, and stormwater inspections. Challenges for this project include remote location and long distance to nearest analytical labs, extensive analytical sample set due to strict requirements from the RWQCB, and short hold times for multiple analyses.



Sheena Smithson
Staff Professional

Project Roles

- ▶ Odor Monitoring Field Team

Specialties

- ▶ Soil Vapor and Vapor Intrusion Investigation
- ▶ Hydrogeologic Sampling and Remediation
- ▶ Subcontractor & Construction Oversight

Education

- ▶ BS, University of South Alabama, Geological Sciences, 2018
- ▶ MS, Brigham Young University, Geological Sciences, 2020

Registration & Certifications

- ▶ 40-hour OSHA HAZWOPER 29 CFR 1910.120(e)(i)
- ▶ 8-hour OSHA HAZWOPER Supervisor Training 29 CFR 1910.120(e)(4)

Career Summary

Sheena Smithson has 1 year of experience in environmental investigation and remediation with Geosyntec Consultants. Her expertise includes soil vapor, vapor intrusion and groundwater investigation methodologies, risk assessment, and subcontractor oversight. In the field, she is proficient in sampling soil vapor and groundwater, soil vapor extraction (SVE) system operations and maintenance (O&M), as well as supervising subcontractors and ensuring adherence to health and safety protocols. She is experienced in field instrumentation and calibration, geochemical data management, modeling, and interpretation. She has worked on several projects in southern California and assisted with the preparation of reports under the oversight of the Air Quality Management District (AQMD), U.S. EPA, the Department of Toxic Substances Control (DTSC), Regional Water Quality Control Board (RWQCB), and local regulatory agencies.

Relevant Project Experience

Santa Barbara Commercial VI, Confidential Client, Santa Barbara, CA. Sheena Smithson assisted in overseeing the construction and subsequent testing of an SVE and sub-slab depressurization (SSD) system at a commercial vapor intrusion (VI) site in Santa Barbara. She provided construction and excavation oversight, subcontractor coordination and scheduling, system sampling and monitoring, soil vapor probe installation and sampling, soil sampling, and continual system O&M. She has also provided continuing field support for indoor and outdoor air sampling at, and around, the site.

Santa Maria Commercial VI, Confidential Client, Santa Barbara, CA. Sheena Smithson supported field soil vapor sampling and reporting efforts associated with VI monitoring of a commercial property impacted by volatile organic compounds (VOCs).

Groundwater Remediation and Commercial/Residential VI Monitoring, Confidential Client, Santa Barbara, CA. Sheena Smithson has performed well installation, well development, soil sampling, and groundwater sampling at a site impacted with chlorinated solvents/VOCs. The site is actively under remediation using in-situ chemical oxidation (ISCO) injections of sodium permanganate in conjunction with enhanced in-situ bioremediation (EISB). She provided drilling and construction oversight, subcontractor coordination and scheduling, and soil and groundwater sampling.

Groundwater Investigation, Confidential Client, San Gabriel Valley, CA. Sheena Smithson has led multiple field operations in the El Monte Operable Unit of the San Gabriel Valley Superfund Site, where groundwater is impacted by VOCs and select emerging compounds. Project tasks include groundwater sampling of Westbay® Multi-port and conventional monitoring wells, contractor oversight, and access coordination for private properties.

PFAs Investigation and Monitoring, Confidential Client, Tucson, AZ. Sheena Smithson supported field sampling efforts associated with PFAs investigation and monitoring at a confidential site located in Tucson Arizona. She performed PFAs sampling using HydraSleeves across a multitude of groundwater wells at, and around, the site.

Construction Dewatering Plan, Confidential Client, Carpinteria, CA. Sheena Smithson assisted with field oversight of the construction dewatering HOV plan. Her role included inspections of drill crew adherence to compliance practices and regular groundwater monitoring of the aquifer and its surrounding area.

ACADEMIC RESEARCH

Sheena Smithson specialized in nutrient cycling within surface water systems in her undergraduate and graduate research. As an undergraduate research assistant, she examined internal sources of nitrogen loading into a brackish lagoon in Dolphin Island, Alabama. Her master's thesis focused on investigating the nutrient cycling system in a highly eutrophic freshwater lake in Utah Valley. Her graduate research was involved in phase 2 of the Utah Lake Water Quality Study, sanctioned by the Utah Division of Water Quality to evaluate the effect of excess nutrients on the lake's ecology. Sheena completed a comprehensive chemical analysis of Utah Lake's surface water, pore water and lakebed sediments. From which, through laboratory and field demonstrations, she evaluated the effects of varying environmental parameters on nutrient uptake/release at the sediment-water interface.

Appendix 2

Geosyntec Consultants Inc. Cannabis Odor Control Systems and Odor Abatement Plan Monitoring Reporting and Compliance Assurance Cost Proposal dated April 21, 2022.

Cost Proposal

Table 1. Cost Estimate Summary

Cannabis Odor Control Systems and Odor Abatement Plan Monitoring, Reporting, and Compliance Assurance Consultant Services
County of Santa Barbara Planning and Development Department

Task	Description	Labor Estimate	Equipment/Supplies Estimate	Subcontractor Estimate	Total Estimate (per event)	Number of Events	Total Estimate Three Years
1*	Initial Odor Control System Inspection, Testing and Reporting	\$ 4,600	\$ 500	\$ 0	\$ 5,100	70	\$ 357,000
2*	Quarterly Odor Control System Inspection, Testing and Reporting	\$ 2,100	\$ 400	\$ 0	\$ 2,500	280	\$ 700,000
3	Review of Proposed OAP Changes and Confirmation Inspection	\$ 4,600	\$ 500	\$ 0	\$ 5,100	12	\$ 61,200
4a	Odor Nuisance Complaint Response	\$ 4,100	\$ 600	\$ 0	\$ 4,700	12	\$ 56,400
4b	Complex Odor Nuisance Complaint Response	\$ 6,900	\$ 600	\$ 6,700	\$ 14,200	12	\$ 170,400
5	Development of Recommendations in Cases of Non-Compliance	\$ 2,900	\$ 0	\$ 0	\$ 2,900	12	\$ 34,800
Three Year Estimate for Primary RFP Tasks							\$ 1,379,800
Annual cost per cultivated acre of cannabis							\$ 256

Assumptions:

Task 1 - Assumes 70 total projects. 42 existing projects and potential for 28 additional projects during the contract period.

Task 2 - Four total, quarterly inspections for 70 sites, upon receipt of an approved OAP, for a maximum total of 280 quarterly site visits.

Task 3 - Assumes one revised OAP per quarter, and includes confirmation field inspection to confirm compliance, similar to level of effort for a Task 1 Initial inspection.

Task 4a - Costs for 1-day to conduct odor complaint response monitoring, assumes one event per quarter. If system in compliance, on-site field time could be less than 1-day.

Task 4b - Costs for up to 2-days to respond and conduct odor complaint response monitoring due to complexity of site and/or system. Includes costs for system inspection and field analytical testing. Assumes 1 event per quarter. If on-site field time is less than 2-days, cost will be reduced.

Task 5 - Assumes development of recommendations to achieve compliance, per quarter, for the contract period.

Assumes Tasks 1 through 4 reporting consists of field notes and supporting photos appended to example Attachment A and uploaded to secure SharePoint site for Department use.

Annual costs per cultivated acre of cannabis assumes 1,800 cultivated acres in Santa Barbara County.

*Note that site mobilization to north county areas may require additional travel time, up to 4-hours and relevant mileage, roundtrip.

Geosyntec will endeavor to schedule multiple site visits in a single day, in the same area, to the extent possible.

Task	Other Tasks	Labor Estimate	Equipment/Supplies Estimate	Subcontractor Estimate	Total Estimate (per event)	Number of Events	Total Estimate Three Years
A	Department Coordination Meetings	\$ 500	\$ 0	\$ 0	\$ 500	29	\$ 14,500
B	Optional Periodic Summary Statistics Reporting to Support Department	\$ 5,400	\$ 0	\$ 0	\$ 5,400	12	\$ 64,800
C	Optional Technical or non-Technical BOS or Public Stakeholder Meetings	\$ 3,500	\$ 0	\$ 0	\$ 3,500	12	\$ 42,000
Three Year Estimate for Optional Tasks							\$ 121,300
Annual cost per cultivated acre of cannabis							\$ 22

Assumptions for Other Tasks:

Task A - Per Q&A item assumes weekly meetings for first 3-months of contract, or 12 meetings, to standardize field data inspection, testing, compliance, and odor nuisance forms for Department and cannabis operator needs. Assumes monthly meetings for remaining 9-months of the first year of the contract. Assumes quarterly meetings for last 2-years of contract, or 8 quarterly meetings. Total of 23 meetings over the 3-year contract term. Assumes PM attendance at meetings with Department, supported by periodic Project Director or Technical Advisor attendance.

Task B - Assumes short 4-page max summary memorandum will be supported by tables of summary statistics on number of OAP inspections and testing completed, regions or locations of inspections, and rates of compliance and non-compliance for the period.

Task C - Assumes reporting data from Task B is used to prepare brief presentation (up to ten PowerPoint slides, maximum) to support a single County Board of Supervisors (BOS) or public stakeholder engagement meeting. Assumes 1-meeting per quarter for the contract period, for a total of 12 meetings.

Annual costs per cultivated acre of cannabis assumes 1,800 cultivated acres in Santa Barbara County.

CANNABIS ODOR CONTROL SYSTEMS AND ODOR ABATEMENT PLAN MONITORING,
REPORTING, AND COMPLIANCE ASSURANCE CONSULTANT SERVICES



Task 1 - Initial Odor Control System Inspection, Testing and Reporting					
Labor Category	Description	No. Units	Rate	Unit	Cost
Senior Principal	Robbie Ettinger / Mark Grivetti / Ruth Custance	1	\$ 275	/hr	\$ 275
Principal	Dan Dowdy - PM	4	\$ 255	/hr	\$1,020
Principal	Maygan Cline / Kate Graf	1	\$ 255	/hr	\$ 255
Senior Professional	Julian Chen / David Oliver	2	\$ 235	/hr	\$ 470
Project Professional	Baird King / Kenjo Agustsson / Justin Whittet	4.5	\$ 208	/hr	\$ 936
Professional	Reese Wilson / Haley Schneider/ John Conroy	8	\$ 185	/hr	\$1,480
Senior Staff Professional	Anabelle Kline	0	\$ 164	/hr	\$ 0
Staff Professional	Steven Thorp / Sheena Smithson	0	\$ 140	/hr	\$ 0
Administrative	Sabrina Hartman	0.5	\$ 78	/hr	\$ 39
Communication Fee	Permits, Subs, ODCs, miscellaneous purchases.	1	3%	ea.	\$ 134
Subtotal Labor:					\$4,600
Equipment Rentals, Permitting & Other Direct Costs (ODCs)	Description	No. Units	Rate	/Unit	Cost
Geosyntec Equipment	Air Flow Meter	1	\$ 75	/day	\$ 75
Geosyntec Equipment	Liquid Flow Meter	1	\$ 100	/day	\$ 100
Geosyntec Equipment	Nasal Ranger	1	\$ 50	/day	\$ 50
Travel	Mileage	150	\$ 0.58	/day	\$ 87
Misc. Field Expenses	Supplies	1	\$ 100	/LS	\$ 100
Handling Fee	5% Expenses	1	12%	ea.	\$ 49
Subtotal Equipment/Supplies:					\$ 500
Geosyntec Subcontractors	Description	No. Units	Rate	/Unit	Cost
VaporSafe	Discrete On-Site Analysis	0	\$3,000	/day	\$ 0
	Continuous on-Site Analysis	0	\$4,000	/day	\$ 0
St. Croix	Odor Analysis	0	\$ 40	ea.	\$ 0
	Terpene Analysis	0	\$ 218	ea.	\$ 0
	Sulfur Analysis	0	\$ 90	ea.	\$ 0
Handling Fee	5% Sub. Expenses	1	12%	ea.	\$ 0
Subtotal Subcontractors:					\$ 0
Initial Odor Control System Inspection, Testing and Reporting (per event)					\$5,100

CANNABIS ODOR CONTROL SYSTEMS AND ODOR ABATEMENT PLAN MONITORING,
REPORTING, AND COMPLIANCE ASSURANCE CONSULTANT SERVICES



Task 2 - Quarterly Odor Control System Inspection, Testing and Reporting					
Labor Category	Description	No. Units	Rate	Unit	Cost
Senior Principal	Robbie Ettinger / Mark Grivetti / Ruth Custance	0.25	\$ 275	/hr	\$ 69
Principal	Dan Dowdy - PM	2	\$ 255	/hr	\$ 510
Principal	Maygan Cline / Kate Graf	0	\$ 255	/hr	\$ -
Senior Professional	Julian Chen / David Oliver	1	\$ 235	/hr	\$ 235
Project Professional	Baird King / Kenjo Agustsson / Justin Whittet	1.5	\$ 208	/hr	\$ 312
Professional	Reese Wilson / Haley Schneider/ John Conroy	4	\$ 185	/hr	\$ 740
Senior Staff Professional	Anabelle Kline	1	\$ 164	/hr	\$ 164
Staff Professional	Steven Thorp / Sheena Smithson	0	\$ 140	/hr	\$ 0
Administrative	Sabrina Hartman	0.5	\$ 78	/hr	\$ 39
Communication Fee	Permits, Subs, ODCs, miscellaneous purchases.	1	3%	ea.	\$ 62
Subtotal Labor:					\$2,100
Equipment Rentals, Permitting & Other Direct Costs (ODCs)	Description	No. Units	Rate	/Unit	Cost
Geosyntec Equipment	Air Flow Meter	1	\$ 75	/day	\$ 38
Geosyntec Equipment	Liquid Flow Meter	1	\$ 100	/day	\$ 100
Geosyntec Equipment	Nasal Ranger	1	\$ 50	/day	\$ 50
Travel	Mileage	150	\$ 0.58	/day	\$ 87
Misc. Field Expenses	Supplies	1	\$ 100	/LS	\$ 100
Handling Fee	5% Expenses	1	12%	ea.	\$ 45
Subtotal Equipment/Supplies:					\$ 400
Geosyntec Subcontractors	Description	No. Units	Rate	/Unit	Cost
VaporSafe	Discrete On-Site Analysis	0	\$3,000	/day	\$ 0
	Continuous on-Site Analysis	0	\$4,000	/day	\$ 0
St. Croix	Odor Analysis	0	\$ 40	ea.	\$ 0
	Terpene Analysis	0	\$ 218	ea.	\$ 0
	Sulfur Analysis	0	\$ 90	ea.	\$ 0
Handling Fee	5% Sub. Expenses	1	12%	ea.	\$ 0
Subtotal Subcontractors:					\$ 0
Quarterly Odor Control System Inspection, Testing and Reporting (per event)					\$2,500

Task 3 - Review of Proposed OAP Changes and Confirmation Inspection

Labor Category	Description	No. Units	Rate	Unit	Cost
Senior Principal	Robbie Ettinger / Mark Grivetti / Ruth Custance	1	\$ 275	/hr	\$ 275
Principal	Dan Dowdy - PM	4	\$ 255	/hr	\$ 1,020
Principal	Maygan Cline / Kate Graf	1	\$ 255	/hr	\$ 255
Senior Professional	Julian Chen / David Oliver	2	\$ 235	/hr	\$ 470
Project Professional	Baird King / Kenjo Agustsson / Justin Whittet	4.5	\$ 208	/hr	\$ 936
Professional	Reese Wilson / Haley Schneider/ John Conroy	8	\$ 185	/hr	\$ 1,480
Senior Staff Professional	Anabelle Kline	0	\$ 164	/hr	\$ 0
Staff Professional	Steven Thorp / Sheena Smithson	0	\$ 140	/hr	\$ 0
Administrative	Sabrina Hartman	0.5	\$ 78	/hr	\$ 39
Communication Fee	Permits, Subs, ODCs, miscellaneous purchases.	1	3%	ea.	\$ 134
Subtotal Labor:					\$ 4,600

Equipment Rentals, Permitting & Other Direct Costs (ODCs)	Description	No. Units	Rate	/Unit	Cost
Geosyntec Equipment	Air Flow Meter	1	\$ 75	/day	\$ 75
Geosyntec Equipment	Liquid Flow Meter	1	\$ 100	/day	\$ 100
Geosyntec Equipment	Nasal Ranger	1	\$ 50	/day	\$ 50
Travel	Mileage	150	\$ 0.58	/day	\$ 87
Misc. Field Expenses	Supplies	1	\$ 100	/LS	\$ 100
Handling Fee	5% Expenses	1	12%	ea.	\$ 49
Subtotal Equipment/Supplies:					\$ 500

Geosyntec Subcontractors	Description	No. Units	Rate	/Unit	Cost
VaporSafe	Discrete On-Site Analysis	0	\$ 3,000	/day	\$ 0
	Continuous on-Site Analysis	0	\$ 4,000	/day	\$ 0
St. Croix	Odor Analysis	0	\$ 40	ea.	\$ 0
	Terpene Analysis	0	\$ 218	ea.	\$ 0
	Sulfur Analysis	0	\$ 90	ea.	\$ 0
Handling Fee	5% Sub. Expenses	1	12%	ea.	\$ 0
Subtotal Subcontractors:					\$ 0

Review of Proposed OAP Changes and Confirmation Inspection (per event) \$ 5,100

CANNABIS ODOR CONTROL SYSTEMS AND ODOR ABATEMENT PLAN MONITORING,
REPORTING, AND COMPLIANCE ASSURANCE CONSULTANT SERVICES

Task 4a - Odor Nuisance Complaint Response					
Labor Category	Description	No. Units	Rate	Unit	Cost
Senior Principal	Robbie Ettinger / Mark Grivetti / Ruth Custance	1	\$ 275	/hr	\$ 275
Principal	Dan Dowdy - PM	2	\$ 255	/hr	\$ 510
Principal	Maygan Cline / Kate Graf	0.5	\$ 255	/hr	\$ 128
Senior Professional	Julian Chen / David Oliver	0.5	\$ 235	/hr	\$ 118
Project Professional	Baird King / Kenjo Agustsson / Justin Whittet	3	\$ 208	/hr	\$ 624
Professional	Reese Wilson / Haley Schneider/ John Conroy	1	\$ 185	/hr	\$ 185
Senior Staff Professional	Anabelle Kline	12	\$ 164	/hr	\$ 1,968
Staff Professional	Steven Thorp / Sheena Smithson	1	\$ 140	/hr	\$ 140
Administrative	Sabrina Hartman	0.5	\$ 78	/hr	\$ 39
Communication Fee	Permits, Subs, ODCs, miscellaneous purchases.	1	3%	ea.	\$ 120
Subtotal Labor:					\$ 4,100
Equipment Rentals, Permitting & Other Direct Costs (ODCs)	Description	No. Units	Rate	/Unit	Cost
Geosyntec Equipment	Air Flow Meter	1	\$ 75	/day	\$ 75
Geosyntec Equipment	Liquid Flow Meter	1	\$ 100	/day	\$ 100
Geosyntec Equipment	Nasal Ranger	1	\$ 50	/day	\$ 50
Travel	Mileage	150	\$ 0.58	/day	\$ 87
Misc. Field Expenses	Supplies	2	\$ 100	/LS	\$ 200
Handling Fee	5% Expenses	1	12%	ea.	\$ 61
Subtotal Equipment/Supplies:					\$ 600
Geosyntec Subcontractors	Description	No. Units	Rate	/Unit	Cost
VaporSafe	Discrete On-Site Analysis	0	\$ 3,000	/day	\$ 0
	Continuous on-Site Analysis	0	\$ 4,000	/day	\$ 0
St. Croix	Odor Analysis	0	\$ 40	ea.	\$ 0
	Terpene Analysis	0	\$ 218	ea.	\$ 0
	Sulfur Analysis	0	\$ 90	ea.	\$ 0
Handling Fee	5% Sub. Expenses	1	12%	ea.	\$ 0
Subtotal Subcontractors:					\$ 0
Odor Nuisance Complaint Response (per event)					\$ 4,700

Task 4b - Complex Odor Nuisance Complaint Response					
Labor Category	Description	No. Units	Rate	Unit	Cost
Senior Principal	Robbie Ettinger / Mark Grivetti / Ruth Custance	1	\$ 275	/hr	\$ 275
Principal	Dan Dowdy - PM	2	\$ 255	/hr	\$ 510
Principal	Maygan Cline / Kate Graf	3	\$ 255	/hr	\$ 765
Senior Professional	Julian Chen / David Oliver	2	\$ 235	/hr	\$ 470
Project Professional	Baird King / Kenjo Agustsson / Justin Whittet	2	\$ 208	/hr	\$ 416
Professional	Reese Wilson / Haley Schneider/ John Conroy	8	\$ 185	/hr	\$ 1,480
Senior Staff Professional	Anabelle Kline	16	\$ 164	/hr	\$ 2,624
Staff Professional	Steven Thorp / Sheena Smithson	1	\$ 140	/hr	\$ 140
Administrative	Sabrina Hartman	0.5	\$ 78	/hr	\$ 39
Communication Fee	Permits, Subs, ODCs, miscellaneous purchases.	1	3%	ea.	\$ 202
Subtotal Labor:					\$ 6,900
Equipment Rentals, Permitting & Other Direct Costs (ODCs)	Description	No. Units	Rate	/Unit	Cost
Geosyntec Equipment	Air Flow Meter	1	\$ 75	/day	\$ 75
Geosyntec Equipment	Liquid Flow Meter	1	\$ 100	/day	\$ 100
Geosyntec Equipment	Nasal Ranger	2	\$ 50	/day	\$ 100
Travel	Mileage	150	\$ 0.58	/day	\$ 87
Misc. Field Expenses	Supplies	2	\$ 100	/LS	\$ 200
Handling Fee	5% Expenses	1	12%	ea.	\$ 67
Subtotal Equipment/Supplies:					\$ 600
Geosyntec Subcontractors	Description	No. Units	Rate	/Unit	Cost
VaporSafe	Discrete On-Site Analysis	2	\$ 3,000	/day	\$ 6,000
	Continuous on-Site Analysis	0	\$ 4,000	/day	\$ 0
St. Croix	Odor Analysis	0	\$ 40	ea.	\$ 0
	Terpene Analysis	0	\$ 218	ea.	\$ 0
	Sulfur Analysis	0	\$ 90	ea.	\$ 0
Handling Fee	5% Sub. Expenses	1	12%	ea.	\$ 720
Subtotal Subcontractors:					\$ 6,700
Complex Odor Nuisance Complaint Response (per event)					\$ 14,200

Task 5 - Development of Recommendations in Cases of Non-Compliance					
Labor Category	Description	No. Units	Rate	Unit	Cost
Senior Principal	Robbie Ettinger / Mark Grivetti / Ruth Custance	0.5	\$ 275	/hr	\$ 138
Principal	Dan Dowdy - PM	3.5	\$ 255	/hr	\$ 893
Principal	Maygan Cline / Kate Graf	1	\$ 255	/hr	\$ 255
Senior Professional	Julian Chen / David Oliver	2.5	\$ 235	/hr	\$ 588
Project Professional	Baird King / Kenjo Agustsson / Justin Whittet	1	\$ 208	/hr	\$ 208
Professional	Reese Wilson / Haley Schneider/ John Conroy	4	\$ 185	/hr	\$ 740
Senior Staff Professional	Anabelle Kline	0	\$ 164	/hr	\$ 0
Staff Professional	Steven Thorp / Sheena Smithson	0	\$ 140	/hr	\$ 0
Administrative	Sabrina Hartman	0.5	\$ 78	/hr	\$ 39
Communication Fee	Permits, Subs, ODCs, miscellaneous purchases.	1	3%	ea.	\$ 86
Subtotal Labor:					\$ 2,900
Equipment Rentals, Permitting & Other Direct Costs (ODCs)	Description	No. Units	Rate	/Unit	Cost
Geosyntec Equipment	Air Flow Meter	0	\$ 75	/day	\$ 0
Geosyntec Equipment	Liquid Flow Meter	0	\$ 100	/day	\$ 0
Geosyntec Equipment	Nasal Ranger	0	\$ 50	/day	\$ 0
Travel	Mileage	0	\$ 0.58	/day	\$ 0
Misc. Field Expenses	Supplies	0	\$ 100	/LS	\$ 0
Handling Fee	5% Expenses	1	12%	ea.	\$ 0
Subtotal Equipment/Supplies:					\$ 0
Geosyntec Subcontractors	Description	No. Units	Rate	/Unit	Cost
VaporSafe	Discrete On-Site Analysis	0	\$ 3,000	/day	\$ 0
	Continuous on-Site Analysis	0	\$ 4,000	/day	\$ 0
St. Croix	Odor Analysis	0	\$ 40	ea.	\$ 0
	Terpene Analysis	0	\$ 218	ea.	\$ 0
	Sulfur Analysis	0	\$ 90	ea.	\$ 0
Handling Fee	5% Sub. Expenses	1	12%	ea.	\$ 0
Subtotal Subcontractors:					\$ 0
Development of Recommendations in Cases of Non-Compliance (per event)					\$ 2,900

CANNABIS ODOR CONTROL SYSTEMS AND ODOR ABATEMENT PLAN MONITORING,
REPORTING, AND COMPLIANCE ASSURANCE CONSULTANT SERVICES



Task A - Department Coordination Meetings					
Labor Category	Description	No. Units	Rate	Unit	Cost
Senior Principal	Robbie Ettinger / Mark Grivetti / Ruth Custance		\$ 275	/hr	\$ \$ 0
Principal	Dan Dowdy - PM	1	\$ 255	/hr	\$ 255
Principal	Maygan Cline / Kate Graf	1	\$ 255	/hr	\$ 255
Senior Professional	Julian Chen / David Oliver		\$ 235	/hr	\$ 0
Project Professional	Baird King / Kenjo Agustsson / Justin Whittet		\$ 208	/hr	\$ 0
Professional	Reese Wilson / Haley Schneider/ John Conroy		\$ 185	/hr	\$ 0
Senior Staff Professional	Anabelle Kline		\$ 164	/hr	\$ 0
Staff Professional	Steven Thorp / Sheena Smithson		\$ 140	/hr	\$ 0
Administrative	Sabrina Hartman		\$ 78	/hr	\$ 0
Communication Fee	Permits, Subs, ODCs, miscellaneous purchases.	1	3%	ea.	\$ 15
Subtotal Labor:					\$ 500

Equipment Rentals, Permitting & Other Direct Costs (ODCs)	Description	No. Units	Rate	/Unit	Cost
Geosyntec Equipment	Air Flow Meter	0	\$ 75	/day	\$ 0
Geosyntec Equipment	Liquid Flow Meter	0	\$ 100	/day	\$ 0
Geosyntec Equipment	Nasal Ranger	0	\$ 50	/day	\$ 0
Travel	Mileage	0	\$ 0.58	/day	\$ 0
Misc. Field Expenses	Supplies	0	\$ 100	/LS	\$ 0
Handling Fee	5% Expenses	0	12%	ea.	\$ 0
Subtotal Equipment/Supplies:					\$ 0

Geosyntec Subcontractors	Description	No. Units	Rate	/Unit	Cost
VaporSafe	Discrete On-Site Analysis	0	\$3,000	/day	\$ 0
	Continuous on-Site Analysis	0	\$4,000	/day	\$ 0
St. Croix	Odor Analysis	0	\$ 40	ea.	\$ 0
	Terpene Analysis	0	\$ 218	ea.	\$ 0
	Sulfur Analysis	0	\$ 90	ea.	\$ 0
Handling Fee	5% Sub. Expenses	1	12%	ea.	\$ 0
Subtotal Subcontractors:					\$ 0

Department Coordination Meetings (per event)					\$ 500
---	--	--	--	--	---------------

CANNABIS ODOR CONTROL SYSTEMS AND ODOR ABATEMENT PLAN MONITORING,
REPORTING, AND COMPLIANCE ASSURANCE CONSULTANT SERVICES



Task B - Optional Periodic Summary Statistics Reporting to Support Department					
Labor Category	Description	No. Units	Rate	Unit	Cost
Senior Principal	Robbie Ettinger / Mark Grivetti / Ruth Custance	2	\$ 275	/hr	\$ 550
Principal	Dan Dowdy - PM	4	\$ 255	/hr	\$ 1,020
Principal	Maygan Cline / Kate Graf	2	\$ 255	/hr	\$ 510
Senior Professional	Julian Chen / David Oliver	4	\$ 235	/hr	\$ 940
Project Professional	Baird King / Kenjo Agustsson / Justin Whittet	4	\$ 208	/hr	\$ 832
Professional	Reese Wilson / Haley Schneider/ John Conroy	4	\$ 185	/hr	\$ 740
Senior Staff Professional	Anabelle Kline	4	\$ 164	/hr	\$ 656
Staff Professional	Steven Thorp / Sheena Smithson	0	\$ 140	/hr	\$ 0
Administrative	Sabrina Hartman	0.5	\$ 78	/hr	\$ 0
Communication Fee	Permits, Subs, ODCs, miscellaneous purchases.	1	3%	ea.	\$ 0
Subtotal Labor:					\$ 5,400
Equipment Rentals, Permitting & Other Direct Costs (ODCs)					
Description	No. Units	Rate	/Unit	\$ 0	
Geosyntec Equipment	Air Flow Meter	0	\$ 75	/day	\$ 0
Geosyntec Equipment	Liquid Flow Meter	0	\$ 100	/day	\$ 0
Geosyntec Equipment	Nasal Ranger	0	\$ 50	/day	\$ 0
Travel	Mileage	0	\$ 0.58	/day	\$ 0
Misc. Field Expenses	Supplies	0	\$ 100	/LS	\$ 0
Handling Fee	5% Expenses	0	12%	ea.	\$ 0
Subtotal Equipment/Supplies:					\$ 0
Geosyntec Subcontractors					
Description	No. Units	Rate	/Unit	Cost	
VaporSafe	Discrete On-Site Analysis	0	\$ 3,000	/day	\$ 0
	Continuous on-Site Analysis	0	\$ 4,000	/day	\$ 0
St. Croix	Odor Analysis	0	\$ 40	ea.	\$ 0
	Terpene Analysis	0	\$ 218	ea.	\$ 0
	Sulfur Analysis	0	\$ 90	ea.	\$ 0
Handling Fee	5% Sub. Expenses	1	12%	ea.	\$ 0
Subtotal Subcontractors:					\$ 0
Optional Periodic Summary Statistics Reporting to Support Department (per event)					\$ 5,400

Task C - Optional Technical or non-Technical BOS or Public Stakeholder Meetings					
Labor Category	Description	No. Units	Rate	Unit	Cost
Senior Principal	Robbie Ettinger / Mark Grivetti / Ruth Custance	6	\$ 275	/hr	\$ 1,650
Principal	Dan Dowdy - PM	4	\$ 255	/hr	\$ 1,020
Principal	Maygan Cline /Kate Graf	0	\$ 255	/hr	\$ 0
Senior Professional	Julian Chen / David Oliver	0.5	\$ 235	/hr	\$ 118
Project Professional	Baird King / Kenjo Agustsson	1	\$ 208	/hr	\$ 208
Professional	Reese Wilson / Haley Schneider/ John Conroy	2	\$ 185	/hr	\$ 370
Senior Staff Professional	Anabelle Kline	0	\$ 164	/hr	\$ 0
Staff Professional	Steven Thorp / Sheena Smithson	0	\$ 140	/hr	\$ 0
Administrative	Sabrina Hartman	0.5	\$ 78	/hr	\$ 39
Communication Fee	Permits, Subs, ODCs, miscellaneous purchases.	1	3%	ea.	\$ 102
Subtotal Labor:					\$ 3,500

Equipment Rentals, Permitting & Other Direct Costs (ODCs)	Description	No. Units	Rate	/Unit	Cost
Geosyntec Equipment	Air Flow Meter	0	\$ 75	/day	\$ 0
Geosyntec Equipment	Liquid Flow Meter	0	\$ 100	/day	\$ 0
Geosyntec Equipment	Nasal Ranger	0	\$ 50	/day	\$ 0
Travel	Mileage	0	\$ 0.58	/day	\$ 0
Misc. Field Expenses	Supplies	0	\$ 100	/LS	\$ 0
Handling Fee	5% Expenses	0	12%	ea.	\$ 0
Subtotal Equipment/Supplies:					\$ 0

Geosyntec Subcontractors	Description	No. Units	Rate	/Unit	Cost
VaporSafe	Discrete On-Site Analysis	0	\$ 3,000	/day	\$ 0
	Continuous on-Site Analysis	0	\$ 4,000	/day	\$ 0
St. Croix	Odor Analysis	0	\$ 40	ea.	\$ 0
	Terpene Analysis	0	\$ 218	ea.	\$ 0
	Sulfur Analysis	0	\$ 90	ea.	\$ 0
Handling Fee	5% Sub. Expenses	1	12%	ea.	\$ 0
Subtotal Subcontractors:					\$ 0

Optional Technical or non-Technical BOS or Public Stakeholder Meetings (per event)					\$ 3,500
---	--	--	--	--	-----------------