

Recording requested by and when recorded mail to:
County of Santa Barbara
Public Works Department
Laguna County Sanitation District
620 West Foster Road
Santa Maria, CA 93455
Attn: Martin Wilder

**COUNTY OF SANTA BARBARA
OFFICIAL BUSINESS**

No fee pursuant to Government Code § 6103
No recording fee per Government Code § 27383

SPACE ABOVE THIS LINE FOR RECORDER'S USE
Easement on APN 129-290-011

The undersigned grantor declares DOCUMENTARY TRANSFER TAX \$ zero (0) EXEMPTION (R&T CODE) §11922 EXPLANATION Municipal government agency
--

EASEMENT DEED

GARY DONVEL CRABTREE AND CHERYLEE CRABTREE, TRUSTEES OF THE
CRABTREE FAMILY TRUST UDTA JULY 27, 2001; as GRANTOR herein,

FOR A VALUABLE CONSIDERATION, DO HEREBY GRANT TO the LAGUNA COUNTY
SANITATION DISTRICT, a county sanitation district of the State of California, as GRANTEE
herein, a permanent easement and right of way for present and future construction,
reconstruction, operation, repair, and maintenance of improvements required by GRANTEE for
GRANTEE's operations related to sewer line improvements, in such number and size, and with
such accessory parts and structures, and with all surface and subsurface appurtenances incidental
thereto, as GRANTEE, or its successors in interest, may from time to time deem necessary to
install within the easement, together with necessary rights of ingress and egress to the easement
for the above-referenced purposes, in, on, along, under and through that certain land situated in
the County of Santa Barbara, State of California, more particularly described in Exhibit "A" (the
"Legal Description") and shown on Exhibit "B" attached hereto and incorporated by this
reference subject to the following terms and conditions:

GRANTOR and its successors in interest retain the right to full use of the easement area except
that within the easement area no structures or buildings can be erected or other use made which
would interfere with or be inconsistent with the use of the easement for the purposes described
herein.

GRANTOR agrees to indemnify, defend and hold harmless GRANTEE and its officers, officials,
employees, agents and volunteers from and against any and all claims, actions, losses, damages,
judgments and/or liabilities arising out of this Deed from any cause whatsoever, including the
acts, errors or omissions of any person or entity and for any costs or expenses (including but not

limited to reasonable attorneys' fees) incurred by GRANTEE on account of any claim except where such indemnification is caused by the sole negligence or willful misconduct of the GRANTEE.

Date: 1-29, 2020

GRANTOR:

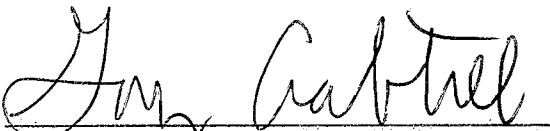

Gary Crabtree



Cheryl Crabtree

ACKNOWLEDGMENT

A notary public or other officer completing this certificate verifies only the identity of the individual who signed the document to which this certificate is attached, and not the truthfulness, accuracy, or validity of that document.

State of California)
)
County of Santa Barbara)

On January 29, 2020 before me, Leanna Shantai Swain, a Notary Public, personally appeared Gary Crabtree, who proved to me on the basis of satisfactory evidence to be the person(s) whose name(s) is/~~are~~ subscribed to within the instrument and acknowledged to me that he/~~she/they~~ executed the same in ~~his/her/their~~ authorized capacity(ies), and that by ~~his/her/their~~ signature(s) on the instrument the person(s), or the entity upon behalf of which the person(s) acted, executed the instrument.

I certify under PENALTY OF PERJURY under the laws of the State of California that the foregoing paragraph is true and correct.

WITNESS my hand and official seal.

Signature 

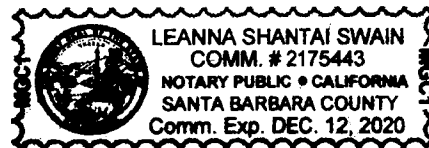

(Seal)

ACKNOWLEDGMENT

A notary public or other officer completing this certificate verifies only the identity of the individual who signed the document to which this certificate is attached, and not the truthfulness, accuracy, or validity of that document.

State of California)
)
County of Santa Barbara)

On January 29, 2020 before me, Leanna Shantai Swain, a Notary Public, personally appeared Cherylee Crabtree, who proved to me on the basis of satisfactory evidence to be the person(s) whose name(s) is/~~are~~ subscribed to within the instrument and acknowledged to me that ~~he~~/she/~~they~~ executed the same in ~~his~~/her/~~their~~ authorized capacity(~~ies~~), and that by ~~his~~/her/~~their~~ signature(s) on the instrument the person(s), or the entity upon behalf of which the person(s) acted, executed the instrument.

I certify under PENALTY OF PERJURY under the laws of the State of California that the foregoing paragraph is true and correct.

WITNESS my hand and official seal.

Signature 

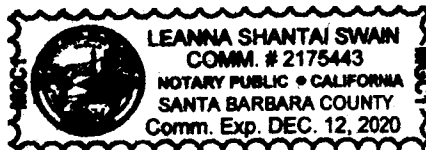

(Seal)

CERTIFICATE OF ACCEPTANCE

STATE OF CALIFORNIA, COUNTY OF SANTA BARBARA: Gov. Code § 27281

THIS IS TO CERTIFY that the interest in real property conveyed by the Easement Deed dated January 29, 2020, from GARY DONVEL CRABTREE AND CHERYLEE CRABTREE, TRUSTEES OF THE CRABTREE FAMILY TRUST UNDER TRUST DATED JULY 27, 2001; as GRANTOR, to the LAGUNA COUNTY SANITATION DISTRICT, a county sanitation district of the State of California, is hereby accepted by order of the Board of Directors of the Laguna County Sanitation District on August 25, 2020 and the Laguna County Sanitation District as GRANTEE consents to recordation thereof by its duly authorized officer.

WITNESS my hand and official seal

this 25th day of August, 2020

MONA MIYASATO
COUNTY EXECUTIVE OFFICER
EX-OFFICIO CLERK OF THE BOARD

By: Shirley de la Guerra
Deputy

APPROVED AS TO FORM
MICHAEL C. GHIZZONI

By: Lina Somait
Lina Somait, Deputy County Counsel

EXHIBIT "A"

1 OF 1

APN 129-290-011
EASEMENT FOR SEWER PURPOSES
LEGAL DESCRIPTION

THE NORTHERLY 30 FEET OF PARCEL "B" AS SHOWN ON THE MAP RECORDED IN BOOK 112 PAGE 39 OF RECORD OF SURVEYS, ON FILE IN THE OFFICE OF THE COUNTY RECORDER OF SANTA BARBARA COUNTY.

AREA = 11,908 SQUARE FEET, MORE OR LESS

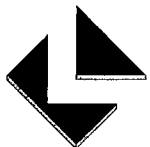

LC ENGINEERING GROUP, INC.

CONSULTING ENGINEERS

889 Pierce Court, Suite 101, Thousand Oaks, California 91360
818-991-7148 • 805-497-1244 • lcegroupinc.com • workfiles@lcegroupinc.com

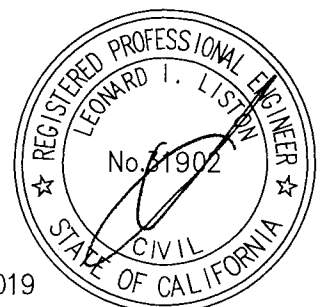

9/25/2019

NORTH LINE OF PARCEL "B" AS SHOWN ON THE MAP RECORDED IN BOOK 112 PAGE 39 OF RECORD OF SURVEYS, ON FILE IN THE OFFICE OF THE COUNTY RECORDER OF SANTA BARBARA COUNTY.

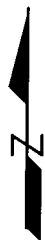
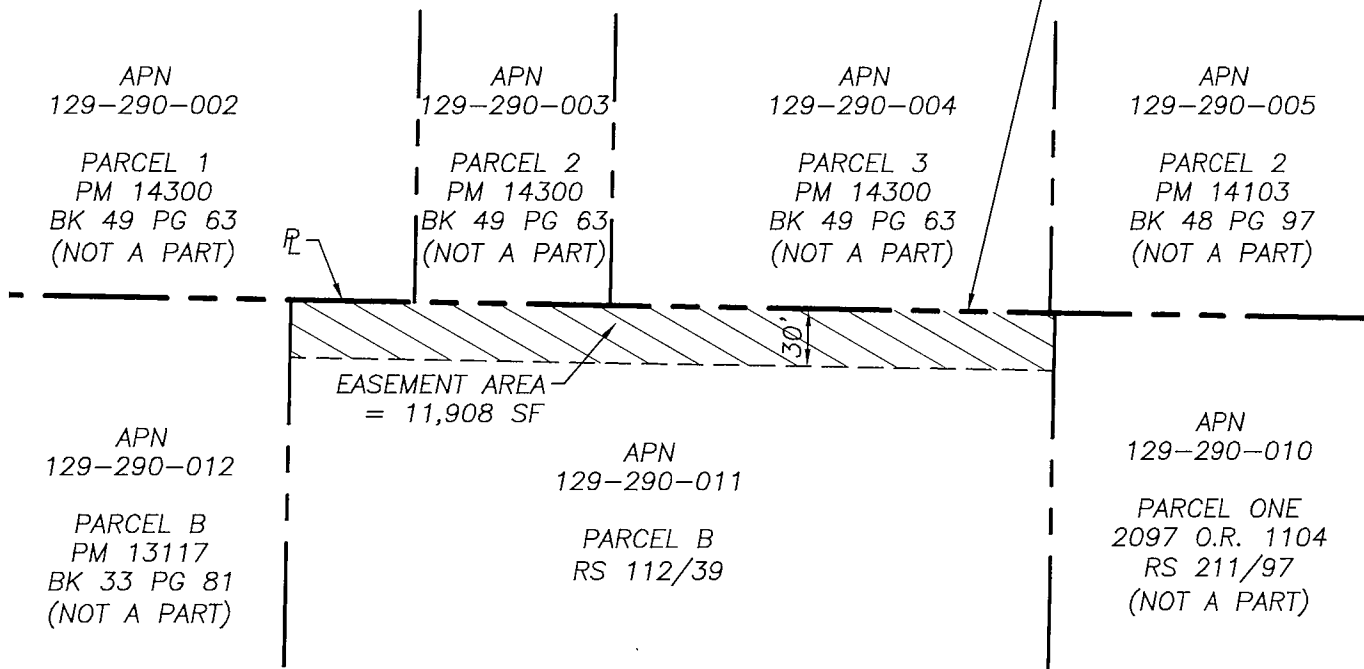

SCALE: 1"=100'

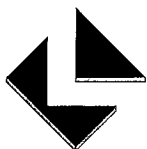

LC ENGINEERING GROUP, INC.

CONSULTING ENGINEERS

889 Pierce Court, Suite 101, Thousand Oaks, California 91360
818-991-7148 • 805-497-1244 • lcegroupinc.com • workfiles@lcegroupinc.com



9/25/2019