

ATTACHMENT A

EXHIBIT A

Contract Agreement

Invitation to Bidders

Payment Bond

Performance Bond

Bid Bond

EXHIBIT B

Contractor's Proposal

EXHIBIT C

Certificate of Transmittal

Certificate of Insurance

EXHIBIT A

EXHIBIT A

Contract Agreement

Invitation to Bidders

Payment Bond

Performance Bond

Bid Bond



**COUNTY OF SANTA BARBARA
AGREEMENT FOR:**

General Services Project No. 22039

County of Santa Barbara
Fire Station 7 Tower Complex
2411 Stanwood Drive, Santa Barbara, CA 91301

BC: _____ - _____

THIS AGREEMENT (“Agreement”) is made by and between the County of Santa Barbara, a political subdivision of the State of California (“COUNTY”), and Normile Construction, Incorporate “CONTRACTOR” and together with COUNTY, collectively, the “Parties” and each individually a “Party”), for the completion of the Work (defined below), on the following terms, conditions, and provisions. All references in the General Terms to the “Agreement” shall have the meaning ascribed to the term “Agreement” in the immediately preceding sentence.

1. **CONTRACT**: This Agreement incorporates by reference all of the General Conditions and Special Conditions, Specifications and Drawings provided by the COUNTY for the Fire Station 7 Tower Complex, Project No. 22039, the Notice to Bidders as amended by Addenda Number 1 , 2, the Bid Bond, the Performance Bond, the Payment Bond, and the proposal or bid documents executed and submitted by the CONTRACTOR for the Project (“Proposal”), to the extent the Proposal is consistent with the provisions of this Agreement other than the Proposal (all of the foregoing documents, together with this Agreement, collectively, the “Contract” or “Contract Documents”). A copy of each of the General and Special Conditions, Specifications and Drawings provided by the COUNTY for the Fire Station 7 Tower Complex, 22039, the Notice to Contractors, the Bid Bond, the Performance Bond, and the Payment Bond are attached hereto as EXHIBIT A, and a copy of the Proposal is attached hereto as EXHIBIT B. All capitalized terms used but not defined herein shall have the respective meanings ascribed to such terms in the Notice to Bidders. Copies of all Contract Documents are on file in the Department of General Services Office of the COUNTY, and have been and will be made available to the CONTRACTOR during the term of this Agreement. CONTRACTOR acknowledges receipt of all Contract Documents.
2. **WORK**: CONTRACTOR, at CONTRACTOR’s own cost and expense, shall perform all the work described in the Contract Documents (“Work”), and shall furnish all equipment and materials necessary to perform and complete the Work, in a good and workmanlike manner and to the satisfaction of the Director of General Services of the COUNTY, all in strict accordance with the Plans and the Contract Documents.
3. **EXCAVATIONS**: Before any pavement resurfacing, displacement, or excavation of the ground that may be required in connection with the Work under this Contract, the CONTRACTOR shall obtain an inquiry identification number by calling Underground Service Alert (USA) 1 (800) 422-4133 or by such other means as may be required; shall conform to all requirements of Sections 4215 through 4217 of the Government Code regarding any such pavement resurfacing, displacement or excavation, including the payment of any fees required; and shall facilitate performance by the COUNTY of any obligation required of the COUNTY under the Government Code. There shall be no performance under this Contract by either party hereto unless and until CONTRACTOR complies with all of the foregoing provisions of this Sections 3, and notifies the County Representative (defined below) in writing regarding such compliance.
4. **COUNTY REPRESENTATIVE**: The “County Representative” referred to in the Contract Documents is Clay Preston
5. **PAYMENT**: As full compensation for furnishing all labor, supervision, overhead, materials, and equipment and for completing all of the Work contemplated by this Contract, and subject to adjustments and liquidated damages, if any, as provided in the Contract Documents, the base amount to be paid to the CONTRACTOR for satisfactory completion of all requirements of the CONTRACTOR under this Contract is and shall be SIX HUNDRED AND, FIFTY-SEVEN THOUSAND, FOUR HUNDRED AND TWENTY DOLLARS \$657,420.00 (“Base Contract Amount”), to be paid as provided in the Contract Documents. The CONTRACTOR assumes and will provide against any loss or damage arising out of the nature of the Work undertaken, or the action of the elements, or from any unforeseen difficulties or obstructions which may arise or be encountered in the performance of the Work until its acceptance by the COUNTY, and assumes any and all expenses incurred by or in consequence of suspension or discontinuance of the Work, for well and faithfully completing the Work and the whole thereof, in the manner and to

the requirements of the Contract and directions of the County Representative.

6. **RIGHT TO AUDIT**: CONTRACTOR shall maintain and make available all books, papers, records, detail costs, estimates, claims, and accounts, including payment, property, payroll, personnel, subcontractors, and financial records related to or which arise in connection with the Contract (collectively, the "Records"). The form of record keeping with respect to the Records shall be subject to approval by COUNTY. The Records shall be made available during normal business hours for examination by COUNTY or the County Representative and shall be retained at CONTRACTOR'S principal place of business in California for audit during normal business hours at such place for four (4) years after the recording of the Notice of Completion for the Project. CONTRACTOR shall provide an office in which COUNTY and the County Representative may conduct such audit(s).

The COUNTY will have the right to audit CONTRACTOR'S Project records. Records must be made available in a form satisfactory to the Santa Barbara County Auditor-Controller.

7. **EXTRA WORK**: Extra work, materials, resolution of disputes, corrections, and/or changes to the specifications as are required for the proper completion of the Work contemplated in the Contract Documents may be effected or authorized in writing duly executed by the County Representative, including agreement(s) providing for compensation in addition to the Base Contract Amount at the same rate per unit (or at a corresponding rate for work that is different from that provided for in the Contract Documents); provided, however, that the aggregate amount of such compensation in addition to the Base Contract Amount shall not exceed ten percent (10%) of the Base Contract Amount or \$25,000, or \$25,000 + 5% of the amount of the bid in excess of \$250,000. Compensation in such other equitable amount as is appropriate for the requirements of the COUNTY may be authorized by resolution or minute order of the Santa Barbara County Board of Supervisors. The County Representative may agree upon an appropriate additional time to be allowed as required for such extra work, materials, resolution, or changes.

8. **COMPLIANCE WITH LAW, AMENDMENTS**: CONTRACTOR shall keep fully informed of, and shall at all times during the Term ensure the performance of the Work is in compliance with, all laws, statutes, ordinances, decrees, orders, and regulations which do or may affect the Project, performance of the Work, the materials used therein, or persons engaged in connection therewith, and all such orders of bodies and tribunals having any jurisdiction over same (collectively, "Applicable Laws"). If it be found that the Special Provisions or Standard Specifications for the Work conflict with any Applicable Law(s), the CONTRACTOR shall immediately report same to the County Representative in writing. CONTRACTOR shall at all times observe and comply with, and shall cause all agents, employees, and subcontractors to observe and comply with, all Applicable Laws. CONTRACTOR acknowledges and shall comply with the provisions of Sections 9364 and Sections 9550 and 9566, inclusive, of the Civil Code of California.

9. **PAYMENTS NOT ACCEPTANCE**: No certificate given or payments made under this Contract, except the final payment hereunder, shall be evidence of the performance of this Contract, either wholly or in part, against any claim upon CONTRACTOR. Final payment for the Work performed under this Contract shall not be made until the lapse of thirty (30) days after the Notice of Completion of the Work has been filed for record and no payment shall be construed to be acceptance of any defective Work or improper materials. CONTRACTOR agrees that the payment for final quantities due under this Contract and the payment of amounts due for any Work in accordance with this Contract shall release the COUNTY from any claims or liabilities on account of Work performed under this Contract, as the same may be amended from time to time during the Term. In addition to guarantees required elsewhere, CONTRACTOR shall and does hereby guarantee all workmanship and material to be free of defects and fit for the purposes intended for a period of one year from and after both the date of acceptance of the work and the recordation of the Notice of Completion by the COUNTY and CONTRACTOR shall repair or replace all Work and materials, together with any other portions of the Work which may be displaced in so doing, that, in the opinion of the County Representative, is or becomes defective during the period of said guarantee, without expense whatsoever to the COUNTY.

10. **PREVAILING WAGE RATES**: Rates of wages, including overtime, holiday, and Sunday rates provided for the Work shall comply with and are subject to the California Labor Code, Sections 1770 et. seq., Executive Orders of the President of the United States No. 9240, dated September 9, 1942, and No. 9250, dated October 3, 1942, and to any modifications thereof, and to any orders of the President or any authorized Federal Officer or agency, insofar as the same may apply to this Contract.

No contractor or subcontractor may be listed on a bid proposal for a public works project unless registered with the Department of Industrial Relations pursuant to Labor Code section 1725.5 [with limited exceptions from this requirement for bid purposes only under Labor Code section 1771.1(a)]. No contractor or subcontractor may be

awarded a contract for public work on a public works project unless registered with the Department of Industrial Relations pursuant to Labor Code section 1725.5. This Project is subject to compliance monitoring and enforcement by the Department of Industrial Relations.

11. CONTRACT DOCUMENTS ACKNOWLEDGED: CONTRACTOR hereby declares that CONTRACTOR has read the Contract Documents, has carefully examined the plans and detailed drawings of the Work to be performed, and fully understands the intent and meaning of the same.

12. TIME FOR COMMENCEMENT, COMPLETION: The Work to be performed under this Contract shall be completed within 275 calendar days after execution of this Agreement ("Term"). As soon as practicable after the Contract has been executed by both the CONTRACTOR and the COUNTY, a Notice to Proceed will be issued by the County Representative stating the starting date of work performance under the Contract. The CONTRACTOR shall begin work within fifteen (15) calendar days after receiving the Notice to Proceed unless otherwise provided therein. The provisions of this Agreement pertaining to Liquidated Damages shall apply in the event of the CONTRACTOR's failure to complete the Work within the Term.

13. WORKERS' COMPENSATION INSURANCE: CONTRACTOR certifies that CONTRACTOR has knowledge of, is in compliance with, and warrants that CONTRACTOR at all times during the TERM shall remain in compliance with, the provisions of Section 3700 of the Labor Code, which requires every employer to be insured against liability for Workers' Compensation or to undertake self-insurance by the provisions of that Code. CONTRACTOR shall comply with such provisions before commencing the performance of the Work.

14. PROGRESS PAYMENT; NO WAIVER FOR DELAY: Any progress payment made after the scheduled completion date for the Work shall not constitute a waiver of any liquidated damages under this Contract.

15. GUARANTEE BONDS: Before any performance under this Contract, the CONTRACTOR shall provide the security required by statute for the payment of all workers and suppliers, and security for the faithful performance of all terms and conditions of this Contract, in an amount and form approved by the COUNTY. Both securities shall contain provisions that automatically increase amounts thereof and/or time of completion or both for all change orders, extensions, and additions to the Work provided under this Contract.

16. DISPUTES: Should any dispute(s) arise respecting the construction or meaning of any of the plans or specifications affecting the Work or respecting the true value of any extra work or work omitted, such dispute(s) shall be resolved by the Project Engineer/Architect, whose decision shall be final and binding upon the parties hereto. If, after the decision of the Project Engineer/Architect as provided herein, claims (as defined in Public Contracts Code Section 20104) under this Contract are filed by CONTRACTOR against COUNTY, and those claims are in the aggregate amount of \$375,000 or less, such claims shall be resolved under Public Contracts Code Sections 20104 through 20104.8, inclusive.

17. SUBSTITUTION OF MATERIALS, SUBSTITUTION OF CONTRACTORS: The County Representative is authorized to act on behalf of the awarding authority in any matters requiring consent, notice, or hearing to substitute materials or equipment specified or to substitute subcontractors.

18. SURVIVAL: All provisions of this Contract which by their nature are intended to survive the termination or expiration of this Agreement shall survive such termination or expiration.

19. INDEMNIFICATION AND INSURANCE: CONTRACTOR shall, at all times during the Term, comply with the indemnification and insurance provisions set forth in EXHIBIT C, attached hereto and incorporated herein by reference.

20. TAXES: CONTRACTOR shall pay all taxes, levies, duties, and assessments of every nature due in connection with any Work under this Contract, and shall make any and all payroll deductions required by law. CONTRACTOR is responsible for all CONTRACTOR personnel and for the payment of their compensation, including, if applicable, withholding of income taxes, and the payment and withholding of social security and other payroll taxes, unemployment insurance, workers' compensation insurance payments, and disability benefits. In no event shall COUNTY pay or be responsible for any taxes imposed on, or with respect to, CONTRACTOR's income, revenues, gross receipts, personnel, real or personal property, or other assets. COUNTY shall not be responsible for paying any taxes on CONTRACTOR's behalf, and should COUNTY be required to do so by state, federal, or local taxing agencies, CONTRACTOR agrees to promptly reimburse COUNTY for the full value of such paid taxes plus interest and penalty, if any. These taxes shall include, but not be limited to, the following: FICA (Social Security), unemployment insurance contributions, income tax, disability insurance, and workers' compensation insurance.

21. CONFLICT OF INTEREST: CONTRACTOR covenants that CONTRACTOR presently has no employment or interest and shall not acquire any employment or interest, direct or indirect, including any interest in any business, property, or source of income, which would conflict in any manner or degree with the performance of Work required to be performed under this Contract. CONTRACTOR further covenants that in the performance of this Contract, no person having any such interest shall be employed by CONTRACTOR. CONTRACTOR must promptly disclose to COUNTY, in writing, any potential conflict of interest. COUNTY retains the right to waive a conflict of interest disclosed by CONTRACTOR if COUNTY determines it to be immaterial, and such waiver is only effective if provided by COUNTY to CONTRACTOR in writing.

22. NONDISCRIMINATION: COUNTY hereby notifies CONTRACTOR that COUNTY's Unlawful Discrimination Ordinance (Article XIII of Chapter 2 of the Santa Barbara County Code) applies to this Contract and is incorporated herein by this reference with the same force and effect as if the ordinance were specifically set out herein and CONTRACTOR agrees to comply with said ordinance.

23. NON-ASSIGNMENT: CONTRACTOR shall not assign, subcontract, delegate, or otherwise transfer, directly or indirectly, whether by operation of law or otherwise ("Transfer") this Contract, in whole or in part, or any of CONTRACTOR's rights or obligations under this Contract, without the prior written consent of COUNTY in each instance. Any attempted or purported Transfer in violation of this Section 24, or in violation of Section 2.08 of the General Conditions, attached hereto as part of Exhibit A, shall be null and void and without legal effect and shall constitute grounds for termination by COUNTY. No Transfer shall relieve CONTRACTOR of any of its obligations hereunder.

24. SEVERABILITY: If any one or more of the provisions contained in the Contract shall for any reason be held to be invalid, illegal or unenforceable in any respect by a court of competent jurisdiction, then such provision or provisions shall be deemed severable from the remaining provisions hereof, and such invalidity, illegality or unenforceability shall not affect any other provision hereof, and this Contract shall be construed as if such invalid, illegal or unenforceable provision had never been contained herein.

25. TIME IS OF THE ESSENCE: Time is of the essence in this Contract, and each covenant and term is a condition herein.

26. ENTIRE AGREEMENT AND AMENDMENT: The Contract Documents, as may be modified from time to time during the Term by duly authorized and executed Change Orders in accordance with the provisions of this Agreement and the General Terms, contain the entire understanding and agreement of the Parties with respect to the subject matter hereof and thereof, and there have been no promises, representations, agreements, warranties or undertakings by any of the Parties, either oral or written, of any character or nature hereafter binding except as set forth herein and therein. This Contract may be altered, amended or modified only by an instrument in writing, duly executed by each of the Parties, and by no other means, except as otherwise set forth in Section 31, below, to the extent such delegated authority is expressly authorized by the COUNTY Board of Supervisors in approving this Contract. Each Party waives its future right to claim, contest or assert that this Agreement was modified, canceled, superseded, or changed by any oral agreements, course of conduct, waiver or estoppel.

27. EXECUTION OF COUNTERPARTS: This Contract may be executed in any number of counterparts and each of such counterparts shall for all purposes be deemed to be an original; and all such counterparts, or as many of them as the Parties shall preserve undestroyed, shall together constitute one and the same instrument.

28. SUBCONTRACTORS: CONTRACTOR is authorized to subcontract with only the subcontractor(s) identified in the Proposal as attached hereto and as set forth in Exhibit B ("Subcontractors"). Contractor shall be fully responsible for all services and Work performed by its Subcontractors. Contractor shall secure from each of its Subcontractors legally binding written agreements to comply with the provisions of this Agreement pertaining to CONTRACTOR's obligations as if such obligations pertained to such Subcontractor, including, but not limited to, audit obligations.

29. CHANGE ORDERS: No Change Order shall be valid or enforceable against the COUNTY unless duly authorized by the COUNTY in accordance with Article 6 of the General Conditions.

30. FLEET REQUIREMENTS: Vehicles with a Gross vehicle weight rating ("GVWR") greater than 8,500 lbs. and light-duty package delivery vehicles operated in California may be subject to the California Air Resources Board ("CARB") Advanced Clean Fleets regulations. Such vehicles may therefore be subject to requirements to reduce

emissions of air pollutants. For more information, please visit the CARB Advanced Clean Fleets webpage at <https://ww2.arb.ca.gov/our-work/programs/advanced-clean-fleets>. Contractor shall at all times have a valid Certificate of Reported Compliance, as described in section 2449(n) of Title 13 of the California Code of Regulations (“CARB Certificate of Compliance”), and shall confirm that each subcontractor listed in Contractor’s Bid has a valid CARB Certificate of Compliance, for each fleet of vehicles subject to 13 CCR section 2449 that may be used in performance of this Contract. No such vehicle is permitted on the project site unless and until Contractor provides County with a valid Certificate of Reported Compliance applicable to such vehicle.”

31. ORDER OF PRECEDENCE: In the event of conflict between the provisions contained in the numbered sections 1 through 31 of this Agreement (“Numbered Section”) and the provisions contained in the Exhibits, the provisions contained in the Numbered Sections of this Agreement shall prevail over those in the Exhibits other than Exhibit C, which Exhibit C shall control and prevail over all other provisions of this Contract. CONTRACTOR agrees that in the event of any discrepancy, inconsistency, gap, ambiguity, or conflicting language between the Bid attached hereto as Exhibit B, on the one hand, and any other provision(s) of this Contract on the other, the provisions of this Contract (including the Numbered Sections of this Agreement, Exhibit A, and Exhibit C) other than Exhibit B shall take precedence and control and prevail over the provisions of the Bid attached hereto as Exhibit B.

IN WITNESS WHEREOF, the parties hereto have executed this Agreement to be effective as of the first date fully executed by all of the parties hereto.

COUNTY

County of Santa Barbara

By: 
0DD6B7A21FC646A...
BOB NELSON, CHAIR
BOARD OF SUPERVISORS

3/12/2026 | 10:17 AM PDT

Dated: _____



ATTEST:
MONA MIYASATO,

CONTRACTOR

Normile Construction, Incorporate, a California corporation

COUNTY EXECUTIVE OFFICER

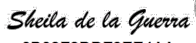
CLERK OF THE BOARD

By: 
Signed by: _____
0B03E3DDE9EE4AA... 

Deputy Clerk of the Board

APPROVED AS TO FORM:
RACHEL VAN MULLEM,
COUNTY COUNSEL

By: _____
Deputy County Counsel
Signed by: 
09B45FFED91E4FC...

APPROVED AS TO FORM:
MARISSA KAHN, ARM
RISK MANAGER

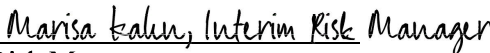
By: 
Signed by: _____
Risk Management

DocuSigned by:
By: 
B6BACA9270AE4D5
Name: Chad Normile
AUTHORIZED REPRESENTATIVE

Title: President

APPROVED AS TO ACCOUNTING FORM:
BETSY SCHAFFER, CPA, CPFO
AUDITOR-CONTROLLER

By: _____
Deputy Auditor-Controller
Signed by: 
0292147E560990E...

RECOMMENDED FOR APPROVAL
KIRK LAGERQUIST, DIRECTOR
GENERAL SERVICES DEPARTMENT

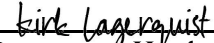
By: 
DocuSigned by: _____
Department Head

RECOMMENDED FOR APPROVAL
CHRIS CHIRGWIN, DIRECTOR
INFORMATION TECHNOLOGY

By: 
DocuSigned by: _____
Department Head
D97209A7A68A4A0...

Dept 067 Fund {1919} Program {8200}

Account {3100} Project {22039}

**COUNTY OF SANTA BARBARA
GENERAL SERVICES DEPARTMENT
CAPITAL PROJECTS DIVISION**



INVITATION FOR BIDS

**Fire Station 7 Communication Complex
2411 Stanwood Drive
Santa Barbara, CA 93103**

COUNTY PROJECT NO. 22039

MANDATORY JOB WALK:

**Friday, November 21, 2025
10:00 AM**

BID DUE DATE:

**Monday, December 22, 2025
3:00 PM**

TABLE OF CONTENTS

BIDDING DOCUMENTS

Notice to Bidders
Bid Form
Designation of Subcontractors
Noncollusion Affidavit
Certificate of Compliance
Bidder's Statements
Anti-fraud Certification
Bidder's Bond

CONTRACT FORMS

Payment Bond
Performance Bond
Certificate of Insurance Transmittal
Unlawful Discrimination Ordinance
County of Santa Barbara Agreement Form

TERMS & CONDITIONS

Special Conditions
General Conditions
Exhibit "C" Indemnification and Insurance Requirements (For Construction Contracts)
Exhibit "D" Change Order Form

DRAWINGS AND SPECIFICATIONS

Civil Drawings
Specification – Tower, Shelter and Generator

BIDDING DOCUMENTS

NOTICE TO BIDDERS

Notice is hereby given that the General Services Department, County of Santa Barbara will receive bids for:

**COUNTY OF SANTA BARBARA
Fire Station 7 Communication Complex
2411 Stanwood Drive
Santa Barbara, CA 93103**

Project No. 22039

**MANDATORY JOB WALK:
Friday, November 21, 2025, at 10:00 AM**

**BID DUE DATE:
Monday, December 22, 2025, at 3:00 PM**

CONSTRUCTION COST ESTIMATE: Estimated cost of construction is **\$500,000.00**

PROJECT LOCATION: 2411 Stanwood Drive, Santa Barbara, CA 93103

MANDATORY JOB WALK: The job walk is MANDATORY on **Friday November 21, 2025, at 10:00 AM.**
Only those prime contractors attending a job walk shall be qualified to bid the project.

PROJECT DESCRIPTION: Project consists of providing and installing 40' Monopole radio tower. The scope of work will include but not limited to providing stamped Structural, Civil and Electrical Engineering drawings, material and labor for installation of tower, 50 Kw generator, one 500-gallon propane tanks, shelter, electrical, HVAC, fencing and coordination with PGE for new service.

CONTRACTOR'S LICENSE: The CONTRACTOR shall possess either a Class A, B or a C-10 license.

QUESTIONS: All questions MUST be submitted electronically through the Public Purchase Portal (www.publicpurchase.com) on or before Friday December 5, 2025 at 3:00 PM. Any changes or additional information needed for bidding will be provided in an Addendum posted on the Public Purchase site. Contractors shall be responsible for addendums.

BID SUBMITTAL INSTRUCTIONS: Each bid shall be in accordance with the plans and specifications approved by the General Services Department. The bid MUST be submitted electronically through the Public Purchase website (www.publicpurchase.com) on or before Monday December 22, 2025, at 3:00 PM.

SUBSTITUTION OF SECURITIES: Pursuant to Section 22300 of the Public Contract Code and the project specifications, the CONTRACTOR may substitute securities or request that the County make payment of retentions to an escrow agent for any money held by the COUNTY to ensure contract performance.

REGISTRATION: No contractor or subcontractor may be listed on a bid proposal for a public works project (submitted on or after March 1, 2015) unless registered with the Department of Industrial Relations pursuant to Labor Code § 1725.5 [with limited exceptions from this requirement for bid purposes only under Labor Code § 1771.1(a)]; no contractor or subcontractor may be awarded a contract for public work on a public works project (awarded on or after April 1, 2015) unless registered with the Department of Industrial Relations pursuant to Labor Code § 1725.5; and this project is subject to compliance monitoring and enforcement by the Department of Industrial Relations.

QUALIFYING CONTRACTOR OR SUBCONTRACTOR: Pursuant to the provisions of Section 4104 of the California Public Contracting Code a contractor or subcontractor shall not be qualified to bid on, be listed in a bid proposal or engage in the performance of any contract for public work, as defined in Section 4104, unless currently registered with the Department of Industrial Relations and qualified to perform public work pursuant to Section 1725.5 California Labor Code.

WITHDRAWAL OF BIDS: The COUNTY reserves the right to reject any and or all bids or waive any informality in a bid. No bidder may withdraw his bid for a period of sixty (60) days after the date set for the opening thereof.

BID SELECTION: The COUNTY reserves the right to select any one or any combination of bids, whichever is in the best interest of the COUNTY.

BID PROTEST: The County of Santa Barbara Bid Protest Procedures are described in Item 10 of the BID FORM, which is included in the bid documents.

CONSTRUCTION TIME: The successful CONTRACTOR (after receiving the Notice to Proceed) shall have 365 calendar days to complete all work called for under the Contract Documents.

LIQUIDATED DAMAGES: The liquidated damages will be **500.00 (Five Hundred Dollars) per day** for project delays that are determined to be attributable to the CONTRACTOR.

BID FORM

1. Pursuant to and in compliance with your Notice to Bidders and the Contract Documents relating to the construction of:

COUNTY OF SANTA BARBARA
Fires Station 7 Communication Complex
2411 Stanwood Drive, Santa Barbara, CA 91301
Project No. 22039
Bid Due Date: Monday, December 22, 2025, at 3:00 PM

including Addendum No(s) ____, ____, ____, ____, ____, ____, the undersigned bidder, having become thoroughly familiar with the terms and conditions of the Contract Documents and with local conditions affecting the performance and the costs of the Work at the place where the Work is to be done, hereby proposes and agrees to fully perform the Work within the time stated in and in strict accordance with the Contract Documents (including the furnishing of any and all labor, materials, tools, expendable equipment and utility and transportation services necessary to fully perform the work and complete it in a workmanlike manner) for the total sum of:

2. **BASE BID:**

\$

--	--

 ,

--	--	--

 ,

--	--	--

 .

--	--

(Place figures in appropriate boxes.)

Estimated number of workdays: _____

3. If the project has additive bid items or additive groups, the lowest responsible bidder will be determined in accordance with Public Contract Code Division II, Part 3, Chapter 1, Section 20103.8, Subdivision (c) and as follows:
 - a. The project funding amount will be disclosed before the first bid is opened.
 - b. The lowest responsible bidder will be determined on the basis of the Total Base Bid plus Total Additive Items or Total Base Bid plus Total Additive Groups, if any.
 - c. In the event that all bids including Total Base Bid plus Total Additive Items or Total Base Bid plus Total Additive Groups exceeds the project funding amount, the lowest bid will be determined on the basis of the Total Base Bid plus those additive items or Total Base Bid plus those additive groups that, when taken in numerical order from the additive list, and added to the Total Base Bid are less than or equal to the funds available.
4. It is understood that Owner reserves the right to reject the proposal and that it shall remain open and not be withdrawn for a period of sixty (60) calendar days from the date prescribed for its opening.
5. Attached hereto and incorporated herein is the complete and entire list of subcontractors to be employed by the undersigned and in the performance of the Work.
6. It is understood and agreed that if written notice of the acceptance of this proposal is mailed or delivered personally to the undersigned bidder within thirty (30) calendar days after the opening of the proposal, or at any time thereafter before it is withdrawn, the undersigned bidder will execute and deliver the Contract Documents to Owner in accordance with the proposal as accepted, and will also furnish and deliver to Owner any Payment Bond required under the provisions of California Civil Code Section 3247 through 3252 and Performance Bond as required under the provisions of the California Government Code and/or California Public Contract Code all within fourteen (14) calendar days after personal delivery or deposit in the mails, as the case may be, of the notifications of award. The

work under the contract shall be commenced by the undersigned bidder on the date stated in COUNTY'S written Notice to Proceed and shall be completed within **365 calendar** days thereafter.

7. Notice of acceptance or request for additional information may be addressed to the undersigned bidder at the business address set forth below.
8. The bid, contract or other submittal of the CONTRACTOR identified below in connection with the foregoing project is not made in the interest of or on behalf of any undisclosed person, partnership, company, association, organization, or corporation; and that the bid is genuine, and not collusive or sham; that the undersigned bidder has not directly or indirectly induced or solicited any other bidder to put in a false or sham bid and has not directly or indirectly colluded, conspired, connived or agreed with any bidder or anyone else to put in a sham bid, or to refrain from bidding; that the undersigned bidder has not directly or indirectly sought by agreement, communication or conference with anyone to fix his bid price or the bid price of any other bidder or to fix any overhead, profit or cost element of such bid price or of that of any other bidder or to secure any advantage against the COUNTY of Santa Barbara of anyone interested in the proposed contract; or all statements contained in this proposal are true; and that the undersigned bidder has not directly or indirectly, submitted his or her bid price or any breakdown thereof, or the contents thereof, or divulged information or data relative thereto, or paid, and will not pay any fee to any corporation, partnership, company association, organization, Bid Depository or to any member or agent thereof to effectuate a collusive or sham bid. I declare under the penalty of perjury under the laws of the State of California that the foregoing is true and correct.
9. Wherever in this proposal an amount is stated in both words and figures, in case of discrepancy between words and figures the words shall prevail; if all or any portion of the proposal is required to be given in unit prices and totals and a discrepancy existing between any such unit prices and totals so given, the unit prices shall prevail.
10. In accordance with the provisions of Sections 1860 and 1861 of the California Labor Code, every CONTRACTOR will be required to secure the payment of compensation of his or her employees. Each CONTRACTOR to whom a public works contract is awarded shall sign the following certification prior to performing the work of the contract: "I am aware of the provisions of Section 3700 of the Labor Code which requires every employer to be insured against liability for worker's compensation or to undertake self-insurance in accordance with the provisions of that code, and I will comply with such provisions before commencing the performance of the work of this contract."
11. Protests of any bid(s) received must be in writing, must specify all grounds for the protest, and must be filed within ten working days after the opening of bids.

CONTRACTOR

Company

IRS No.: _____

Street Address

License Classification(s): _____

City

Phone Number: _____

BY: _____
Signature

Printed Name, Title

NONCOLLUSION AFFIDAVIT

In accordance with Public Contract Code [§ 7106](#). _____

(Bidder's full name)

being first duly sworn, deposes and says that he or she is _____

(Bidder's title)

of _____

(Company's name)

the party making the foregoing Bid, that the Bid is not made in the interest of, or on behalf of, any undisclosed person, partnership, company, association, organization, or corporation; that the Bid is genuine and not collusive or sham; that the Bidder has not directly or indirectly induced or solicited any other bidder to put in a false or sham Bid, and has not directly or indirectly colluded, conspired, connived, or agreed with any Bidder or anyone else to put in a sham Bid, or that anyone shall refrain from bidding; that the Bidder has not in any manner, directly or indirectly, sought by agreement, communication, or conference with anyone to fix the Bid price of the Bidder or any other Bidder, or to fix any overhead, profit, or cost element of the Bid price, or of that of any other Bidder, or to secure any advantage against the public body awarding the contract of anyone interested in the proposed Contract; that all statements contained in the Bid are true; and further, that the Bidder has not, directly or indirectly, submitted his or her bid price or any breakdown thereof, or the contents thereof, or divulged information or data relative thereto, to any corporation, partnership, company, association, organization, bid depository, or to any member or agent thereof to effectuate a collusive or sham Bid and has not paid, and will not pay, any person or entity for such purpose.

Any person executing this declaration on behalf of a bidder that is a corporation, partnership, joint venture, limited liability company, limited liability partnership, or any other entity, hereby represents that he or she has full power to execute, and does execute, this declaration on behalf of the bidder.

I declare under penalty of perjury under the laws of the State of California that the foregoing is true and correct.

SIGNATURE BLOCK (<i>Signature Block must be completed in ink & changes must be initialed.</i>)	
Bidder's Signature: _____	Date: _____
Bidder's Name & Title (Print): _____	
At CITY: _____	STATE: _____

CERTIFICATE OF COMPLIANCE

This is to certify that all requirements for insurance of subcontractors as specified for this project will be met.

Dated

Signature of Principal

Printed Name, Title of Principal

Company

Address

City, State & Zip

BIDDER'S STATEMENTS

REGARDING INSURANCE COVERAGE:

Bidder hereby certifies that he has reviewed the insurance coverage requirements specified in the Contract Forms. Should he be awarded the contract for the work, Bidder further certifies that he can meet all the Contract Specification requirements for insurance including insurance coverage of his subcontractors.

REGARDING TITLE 13 OF THE CA CODE OF REGULATIONS, BIDDER'S FLEET:

Bidder must provide to the County, prior to executing the Contract, a true and correct copy of each valid Certificate of Reported Compliance, as described in section 2449(n) of Title 13 of the California Code of Regulations, for Bidder's fleet, and for each fleet of each subcontractor listed in Bidder's Bid, of vehicles subject to 13 CCR section 2449 that may be used in performance of the Contract.

REGARDING PUBLIC CONTRACT CODE SECTION 10232:

In accordance with Public Contract Code Section 10232, the Contractor hereby states, under penalty of perjury, that no more than one final unappealable finding of contempt of court by a Federal Court has been issued against the Contractor within the immediately preceding two year period because of the Contractor's failure to comply with an order of a Federal Court which orders the Contractor to comply with an order of the National Labor Relations Board.

REGARDING PUBLIC CONTRACT CODE SECTION 10162:

In accordance with Public Contract Code Section 10162, the Bidder shall complete, under penalty of perjury, the following questionnaire:

Has the bidder, any officer of the bidder, or any employee of the bidder who has proprietary interest in the bidder, ever been disqualified, removed, or otherwise prevented from bidding on, or completing, a federal, state, or local government project because of a violation of law or safety regulation?

Yes _____

No _____

(If the answer is yes, explain the circumstances on a separate sheet of paper and attach to proposal)

Date

Signature of Principal

Printed Name, Title of Principal

Company

Address

City, State & Zip

ANTI-FRAUD CERTIFICATION

COUNTY OF SANTA BARBARA
Fires Station 7 Communication Complex
2411 Stanwood Drive, Santa Barbara, CA 91301
Project No. 22039
Bid Due Date: Monday December 22,2025

In accordance with Public Contract Code Section 10285.1 (Chapter 376, Stats. 1985), the bidder hereby declares under penalty of perjury that the bidder **has** __, **has not** __, been convicted within the preceding three years of any offenses referred to in that section, including any charge of fraud, bribery, collusion, conspiracy, or any other act in violation of any state or federal antitrust law in connection with the bidding upon award of, or performance of, any public works contract, as defined in Public Contract Code Section 1101, with any public entity, as defined in Public Contract Code Section 1100, including the Regents of the University of California or Trustees of the California State University.

The term "bidder" is understood to include any partner, member, officer, director, responsible managing officer, or responsible managing employee thereof, as referred to in Section 10285.1.

NOTE: The bidder must place a check mark after "has" or "has not" in one of the blank spaces provided.

Date

Signature of Principal

Printed Name, Title of Principal

Company

Address

City, State & Zip

BIDDER'S BOND

KNOW ALL MEN BY THESE PRESENTS:

That we, _____ as Principal, and _____ as Surety (hereinafter referred to as Surety), are held firmly bound unto the County of Santa Barbara, State of California (hereinafter called "Owner") in the penal sum of Ten Percent (10%) of the total aggregate amount of the bid of the Principal above named, submitted by said Principal to Owner for the work described below, for the payment of which sum in lawful money of the United States, well and truly to be made, we bind ourselves, our heirs, executors, administrators, and successors, jointly and severally, firmly by these presents. Surety shall be and hereby warrants that it is listed in the Insurance Organizations Authorized by the Insurance Commissioner to Transact Business of Insurance in the State of California, published by the Department of Insurance, State of California or successor publications. In no case shall the liability of the Surety hereunder exceed the sum of _____ DOLLARS (\$ _____). The condition of this obligation is such that a bid to Owner for certain construction specifically described as follows:

**COUNTY OF SANTA BARBARA
Fires Station 7 Communication Complex
2411 Stanwood Drive, Santa Barbara, CA 91301
Project No. 22039**

for which bids are due on Monday December 22, 2025 at 3:00 PM has been submitted by Principal to Owner.

NOW, THEREFORE, if the aforesaid Principal shall not withdraw said bid within the period therein after the opening of the same, or, if no period be specified within sixty (60) days after said opening and shall within the period specified therefore, or, if no period be specified, within eight (8) days after the prescribed forms are presented to him for signature, enter into a written Contract with Owner, in the prescribed form, in accordance with the bid as accepted, and file the two Bonds with Owner, one to guarantee faithful performance and the other to guarantee payment for labor and materials, as required by law, then this obligation shall be null and void; otherwise, it shall remain in full force, virtue and affect.

Said Surety, for value received, hereby stipulates and agrees that no change, extension of time, alteration or addition to the terms of said Contract or to the work to be performed thereunder or the Specifications accompanying the same shall in any manner affects its obligations on this bond, and it does hereby waive notice of any change, extension, alteration, or addition.

It is hereby agreed that any progress payment made after the scheduled completion date will not constitute a waiver of any liquidated damages heretofore agreed upon.

In the event suit is brought upon said Bond by Owner and judgment is recovered, the Surety shall pay all costs incurred by Owner in such suit, including a reasonable attorney's fee to be fixed by the Court.

Death, Bankruptcy, Receivership, Going Out of Business for any reason, or incompetence of the Principal shall not relieve the Surety of its obligations hereunder.

Name of Principal

Dated _____

Signature of Principal (Seal)

Name of Surety

Address

City, State & Zip

Dated _____

Signature of Surety's Attorney-in-fact (Seal)

Surety's Agent for Service of Process (located within the State of California):

Name of Agent

Address

City, State & Zip

Telephone Number

FAX Number

NOTE: Signatures of those executing for Surety MUST be properly acknowledged. This form may be reproduced for transmittal to the Surety for execution and attached to the front of the original Bid Bond Form.

CONTRACT FORMS

PAYMENT BOND

KNOW ALL MEN BY THESE PRESENTS:

That the County of Santa Barbara of the State of California (hereinafter referred to as the County) and _____
(hereinafter referred to as Principal) have by written agreement dated _____, entered into a contract identified as:

Project Title: County of Santa Barbara
Fire Station 7 Communication Complex
2411 Stanwood Drive, Santa Barbara, CA 93101
Project No. 22039

(Hereinafter referred to as the Contract) and

That, pursuant to law and to said Contract, and before entering upon the performance of said Contract, the principal is required to file with the County a good and sufficient bond to secure the payment of labor and materials claims.

NOW, THEREFORE, said Principal and _____

_____ as corporate surety (hereinafter referred to as Surety), are held firmly bound unto the County in the amount of \$_____, for the payment of which Principal and Surety bind themselves, their heirs, executors, administrators, successors and assigns both jointly and severally. Surety shall be and hereby warrants that it is listed in the Insurance Organizations Authorized by the Insurance Commissioner to Transact Business of Insurance in the State of California, published by the Department of Insurance, State of California or successor publications.

THE CONDITION OF THIS OBLIGATION IS SUCH that if said principal, his or its subcontractors, heirs, executors, administrators, successors, or assigns, shall fail to pay any of the persons named or referred to in Section 9100 of the California Civil Code, or amounts due under Unemployment Insurance Code with respect to work or labor performed by any such claimant, or for any amounts required to be deducted, withheld and paid over to the Employment Development Department from the wages of employees of the Contractor and his subcontractors pursuant to Section 13020 of the Unemployment Insurance Code with respect to such work and labor as required by the California Civil Code, or this bond, then said Surety will pay for the same, in an amount not to exceed the amount hereinafter set forth.

This bond shall insure to the benefit of any and all persons, entities, companies and corporations named or referred to in Section 9100 of the California Civil Code, so as to give a right of action to them or their assign in any suit brought upon this bond.

And the said Surety, for value received, hereby agrees that no change, extension of time, alteration or addition to the terms of the Contract, or to the work to be performed thereunder, or the Specifications accompanying the same, shall in anywise affect its obligations on this bond, and it does hereby waive notice of any such change, extension of time, alteration or addition to the terms of the Contract or to the Specifications.

In the event suit is brought upon this Bond by County and judgment is recovered, Surety shall pay all costs incurred by the County in such suit, including a reasonable attorney's fee to be fixed by the court.

Death, illness, disability or disqualification of the Principal shall not relieve Surety of its obligations hereunder.

Principal

Surety

By: _____

Signature of Attorney-in-fact

DATED: _____

Address

City, State & Zip Code

Surety's Agent for Service of Process (located within the State of California):

Name of Agent

Address

City, State & Zip Code

Telephone Number

FAX Number

NOTE: Signature of those executing for Surety must be properly acknowledged.

PERFORMANCE BOND

KNOW ALL MEN BY THESE PRESENTS:

That the County of Santa Barbara of the State of California (hereinafter referred to as the County) and (hereinafter referred to as Principal) have by written agreement dated _____, entered into a contract identified as:

Project Title: County of Santa Barbara
Fire Station 7 Communication Complex
2411 Stanwood Drive, Santa Barbara, CA 93103
Project No. 22039

(Hereinafter referred to as the Contract) and

That, pursuant to law and to said Contract, and before entering upon the performance of said Contract, the Principal is required under the terms and conditions of said Contract to furnish a bond for the faithful performance of Contract.

NOW, THEREFORE, said Principal and _____

_____ as corporate surety (hereinafter referred to as Surety), are held firmly bound unto the County in the amount of \$_____, for the payment of which Principal and Surety bind themselves, their heirs, executors, administrators, successors and assigns both jointly and severally. Surety shall be and hereby warrants that it is listed in the Insurance Organizations Authorized by the Insurance Commissioner to Transact Business of Insurance in the State of California, published by the Department of Insurance, State of California or successor publications.

THE CONDITION OF THIS OBLIGATION IS SUCH that if the Principal, his heirs, executors, administrators, successors, or assigns, shall perform all of the covenants, conditions and agreements in said Contract and any alteration thereof made as herein provided, in his or their part, to be kept and performed at the time, and in the manner therein specified, and shall indemnify and save harmless County, its officers, agents, and employees, as therein stipulated, then this obligation shall become null and void; otherwise it shall be and remain in full force, virtue and effect.

And the said Surety, for value received, hereby agrees that no change, extension of time, alteration or addition to the terms of the Contract, or to the work to be performed thereunder, or the specifications accompanying the same shall in anywise affect its obligations on this bond, and it does hereby waive notice of any such change, extension of time, alteration or additions to the terms of the Contract or to the work or to the specifications.

In the event suit is brought upon this Bond by County and judgment is recovered, Surety shall pay all costs incurred by the County in such suit, including a reasonable attorney's fee to be fixed by the court.

Death, illness, disability or disqualification of the Principal shall not relieve Surety of its obligations hereunder.

Principal

Surety

By: _____

Signature of Attorney-in-fact

DATED: _____

Address

City, State & Zip Code

Surety's Agent for Service of Process (located within the State of California):

Name of Agent

Address

City, State & Zip Code

Telephone Number

FAX Number

NOTE: Signature of those executing for Surety must be properly acknowledged.



CERTIFICATE OF INSURANCE TRANSMITTAL FORM

FOR THE FOLLOWING DESCRIBED PROJECT:

County of Santa Barbara
Fire Station 7 Communication Complex
2411 Stanwood Drive, Santa Barbara, CA 93103
Project No. 22039

CONTRACTOR:

Name

Address

City, State & Zip Code

The successful bidder shall furnish satisfactory proof of the maintenance of adequate Worker's Compensation Insurance, and the maintenance of Comprehensive General and Automobile Liability Insurance in the amount of not less than \$1,000,000 per occurrence and \$2,000,000 in the aggregate. The County of Santa Barbara (COUNTY), its officers, employees, and agents shall be named as additional insured on all certificates. A copy of the endorsement evidencing that the County has been added to the policy must be attached to the certificate of insurance. Said policy or policies shall provide that the COUNTY shall be given thirty (30) days written notice prior to cancellation or expiration of the policy or reduction in coverage. Refer to section 5.18 of the General Conditions.

In addition to the above, the following information must appear on the certificates:

County of Santa Barbara
Fire Station 7 Communication Complex
2411 Stanwood Drive, Santa Barbara, CA 93013
Project No. 22039

This form must be attached to all insurance forms sent to the County of Santa Barbara, General Services Department:

Authorized Insurance Company Representative's Signature

This form may be reproduced as required.

COUNTY OF SANTA BARBARA UNLAWFUL DISCRIMINATION ORDINANCE

Section 2-95. Prohibition of unlawful discrimination in employment practices. The COUNTY reserves the right to terminate forthwith each and every written contract and agreement (except purchase orders) respecting real property for goods and/or services entered into by the COUNTY or by its joint powers, agencies, or agents with the consent of the other parties (hereinafter called "CONTRACTOR") including but not limited to concessions, franchises, construction agreements, leases, whether now in effect or hereinafter made if the COUNTY finds that the CONTRACTOR is discriminating or has discriminated against any employee or applicant for employment in violation of any applicable state or federal laws, rules, or regulations which may now or hereafter specifically prohibit such discrimination on such grounds as race, religion, sex, color, national origin, physical or mental handicap when otherwise qualified, Vietnam war veteran/disabled, age, medical condition, marital status, ancestry, sexual orientation, or other legally protected status.

Such finding may only be made after CONTRACTOR has had a full and fair hearing on notice of thirty (30) days before an impartial hearing officer at which hearing CONTRACTOR may introduce evidence, produce witness, and have the opportunity to cross-examine witnesses produced by the COUNTY. Further, any finding of discrimination must be fully supported by the facts developed at such hearing and set forth in a written opinion; and in addition, CONTRACTOR may move in the appropriate court of law for damages and/or to compel specific performance of a CONTRACTOR or agreement if any of the above procedures are not afforded to the CONTRACTOR. If CONTRACTOR is not found to have engaged in unlawful discriminatory practices, COUNTY shall pay all costs and expense of such hearing, including reasonable attorney's fees to CONTRACTOR in accordance with current Santa Barbara County Superior Court schedule of attorney's fees for civil trials. If CONTRACTOR is found to have engaged in such unlawful discriminatory employment practices, CONTRACTOR shall pay all such costs, expenses, and attorney's fees.

Whether or not a contract or agreement is still in existence at the time of final determination of such unlawful discrimination, the CONTRACTOR shall forthwith reimburse COUNTY for all damages directly stemming from such discrimination; however, those damages shall not exceed and are not reimbursable in an amount which exceeds amounts paid CONTRACTOR under the terms of the contract or agreement.

Nothing in this Section 2-95 shall directly or by interpretation give a private cause of action to any third party (not a signatory to the contract or agreement) including employees past or present, or applicants for employment to CONTRACTOR, it being the sole purpose of this clause to administratively assure compliance with the nondiscrimination clauses contained herein.

Employment practices shall include, but are not limited to employment, promotion, demotion, transfer, recruitment and advertising for recruitment, layoff or other termination, rate of pay, employee benefits, and all other forms of compensation selection for training and apprenticeship and probationary periods.

CONTRACTOR shall permit access at all reasonable time and places to all of its records of employment, advertising, application forms, tests, and all other pertinent employment data and records, to the COUNTY, its officers, employees, and agents for the purpose of investigation to ascertain if any unlawful discrimination as described herein has occurred or is being practiced, provided that such records are relevant to a complaint of an unlawful discriminatory practice which has been forwarded to CONTRACTOR reasonably prior to the time CONTRACTOR is asked to make such records available. In addition, all such records shall be deemed "Confidential" by the officers, employees, and agents of the COUNTY. No records or copies of such records may be removed from the premises of CONTRACTOR and no disclosure, oral, or written of such record, may be made to third parties except as provided within the agreement.

Provided, however, that in the event of a hearing to determine whether or not CONTRACTOR is engaging in unlawful discrimination in employment practices as defined herein, the Board of Supervisor of Santa Barbara County may issue subpoenas to require that certified copies of such records be made available to the hearing.

Failure to fully comply with any of the foregoing provisions relating to unlawful discrimination in employment practices shall be deemed to be a material breach of any contract or agreement with the COUNTY. All persons contracting with or who have contracts for goods or services with the COUNTY shall be notified that this chapter applied to their contract or agreement with the COUNTY (Ordinance No. 2946, SS1; Ordinance No. 2993, SS1; and Ordinance No. 3018, SS1).

Section 2-95.5. Exceptions. Notwithstanding any other provisions in this article, any party contracting with the COUNTY having an affirmative action program which has been approved within twelve (12) months from the date of the contract by an agency of the federal government shall be deemed to be in compliance with the provisions of this article upon furnishing documentary evidence of such approval satisfactory to the COUNTY affirmative action officer. Loss of such approval shall be immediately reported by such party to the COUNTY affirmative action officer.

Section 2-96. Purchase orders. Purchase orders shall contain the following clause as grounds for termination of such purchase orders:

"If complaint is made that seller is engaging in discriminatory employment practices made unlawful by applicable state and federal laws, rules, or regulations, and the State Fair Employment Practice Commission or the Federal Equal Employment Opportunities Commission determines that such unlawful discrimination exists, then the COUNTY may forthwith terminate this order." (Ordinance No. 2946, SS 1)

Section 2-97. Affirmative action officer. At the discretion of the COUNTY affirmative action officer, he or she shall promptly and thoroughly investigate, or cause to be investigated reports and complaints from whatever source, that any party contracting with the COUNTY is engaging, or during the term of a contract or agreement with the COUNTY has engaged, in any unlawful discriminatory employment practices as described in Section 2-95 of this Code. If the investigation discloses reason to believe such unlawful discrimination does exist or has existed and the conditions giving rise thereto have not been changed so as to prevent further such unlawful discrimination, and the said party shall forthwith terminate such unlawful discrimination, take all appropriate steps to prevent a recurrence of such or other unlawful practices, and compensate the person or persons unlawfully discriminated against for any and all loss incurred by reason of such unlawful discrimination, all to the satisfaction of the affirmative action officer, then the affirmative action officer shall cause the matter to be presented for action to the State Fair Employment Practices Commission or the Federal Equal Employment Opportunities Commission, or both, and to any other concerned state or federal agencies or officers.

If and when it has been finally determined by the affirmative action officer, COUNTY counsel, or state or federal regulatory agencies that such unlawful discriminatory employment practice has in fact so occurred or are being carried on, then the affirmative action officer shall forthwith present the entire matter to the Board of Supervisors of the COUNTY, together with all damages, costs, and expense related thereto and incurred by COUNTY, for appropriate action by the Board of Supervisors in accord with the intent and purposes of this article and of the affirmative action program of the COUNTY (Ordinance No. 2946, SS 1)



CONTRACT SAMPLE

COUNTY OF SANTA BARBARA
AGREEMENT FOR:
General Services Project No. 22039
 County of Santa Barbara
 Fire Station 7 Communication Complex
 2411 Stanwood Drive, Santa Barbara, CA
 BC: _____ - _____

THIS AGREEMENT (“Agreement”) is made by and between the County of Santa Barbara, a political subdivision of the State of California (“COUNTY”), and {FULL LEGAL NAME OF CONTRACTOR} (“CONTRACTOR” and together with COUNTY, collectively, the “Parties” and each individually a “Party”), for the completion of the Work (defined below), on the following terms, conditions, and provisions. All references in the General Terms to the “Agreement” shall have the meaning ascribed to the term “Agreement” in the immediately preceding sentence.

1. **CONTRACT**: This Agreement incorporates by reference all of the General Conditions and Special Conditions, Specifications and Drawings provided by the COUNTY for the Fire Station 7 Communication Complex, Project No. 22039, the Invitation for Bids as amended by Addenda Number {xx-xx}, the Bid Bond, the Performance Bond, the Payment Bond, and the bid documents executed and submitted by the CONTRACTOR for the Project (“Bid”), to the extent the Bid is consistent with the provisions of this Agreement other than the Bid (all of the foregoing documents, together with this Agreement, collectively, the “Contract” or “Contract Documents”). A copy of each of the General and Special Conditions, Specifications and Drawings provided by the COUNTY for the Fire Station 7 Communication Complex, Project No. 22039, the Notice to Bidders, the Bid Bond, the Performance Bond, and the Payment Bond are attached hereto as EXHIBIT A, and a copy of the Bid is attached hereto as EXHIBIT B. All capitalized terms used but not defined herein shall have the respective meanings ascribed to such terms in the Notice to Bidders. Copies of all Contract Documents are on file in the Department of General Services Office of the COUNTY and have been and will be made available to the CONTRACTOR during the term of this Agreement. CONTRACTOR acknowledges receipt of all Contract Documents.
2. **WORK**: CONTRACTOR, at CONTRACTOR’s own cost and expense, shall perform all the work described in the Contract Documents (“Work”), and shall furnish all equipment and materials necessary to perform and complete the Work, in a good and workmanlike manner and to the satisfaction of the Director of the COUNTY’s General Services Department (“Director”), or the Director’s designee, all in strict accordance with the Contract Documents.
3. **EXCAVATIONS**: Before any pavement resurfacing, displacement, or excavation of the ground that may be required in connection with the Work under this Contract, the CONTRACTOR shall obtain an inquiry identification number by calling Underground Service Alert (USA) 1 (800) 422-4133 or by such other means as may be required; shall conform to all requirements of Sections 4215 through 4217 of the Government Code regarding any such pavement resurfacing, displacement or excavation, including the payment of any fees required; and shall facilitate performance by the COUNTY of any obligation required of the COUNTY under the Government Code. There shall be no performance under this Contract by either party hereto unless and until CONTRACTOR complies with all of the foregoing provisions of this Sections 3, and notifies the County Representative (defined below) in writing regarding such compliance.
4. **COUNTY REPRESENTATIVE**: The “County Representative” referred to in the Contract Documents is Clay Preston.
5. **PAYMENT**: As full compensation for furnishing all labor, supervision, overhead, materials, and equipment and for completing all of the Work contemplated by this Contract, and subject to adjustments and liquidated damages, if any, as provided in the Contract Documents, the base amount to be paid to the CONTRACTOR for satisfactory completion of all requirements of the CONTRACTOR under this Contract is and shall be {WRITTEN AMOUNT IN DOLLARS AND CENTS} (\$NUMERICAL) (“Base Contract Amount”), to be paid as provided in the Contract Documents. CONTRACTOR assumes and will provide against any loss or damage arising out of the nature of the Work undertaken, or the action of the elements, or from any unforeseen difficulties or obstructions which may arise or be encountered in the performance of the Work until its acceptance by the COUNTY, and assumes any and all expenses incurred by or in consequence of suspension or discontinuance of the Work, for well and faithfully completing the Work and the whole thereof, in the manner and to the requirements of the Contract and directions of the County Representative to the extent not inconsistent with any provisions of the Contract Documents.
6. **RIGHT TO AUDIT**: CONTRACTOR shall maintain and make available all books, papers, records, detail costs, estimates, claims, and accounts, including payment, property, payroll, personnel, subcontractors, and financial records related to or which arise in connection with the Contract (collectively, the “Records”). The form of record keeping with respect to the Records shall be subject to approval by COUNTY. The Records shall be made available during normal business hours for examination by COUNTY or the County Representative and shall be retained at CONTRACTOR’S principal place of business in California for

audit during normal business hours at such place for four (4) years after the recording of the Notice of Completion for the Project. CONTRACTOR shall provide an office in which COUNTY and the County Representative may conduct such audit(s).

The COUNTY will have the right to audit CONTRACTOR'S Project records. Records must be made available in a form satisfactory to the Santa Barbara County Auditor-Controller.

7. **EXTRA WORK**: Extra work and materials, may only be authorized via written Change Order(s) duly executed by the Director or his designee in accordance with Section 30, below, including Change Order(s) providing for compensation in addition to the Base Contract Amount; *provided, however*, that the aggregate amount of such compensation in addition to the Base Contract Amount that may be authorized by the Director or his designee pursuant to duly executed Change Orders shall not exceed \$[] (“Contingency Amount”). Compensation in such other equitable amount as is appropriate for the requirements of the COUNTY may be authorized by resolution or minute order of the Santa Barbara County Board of Supervisors.

8. **COMPLIANCE WITH LAW**: CONTRACTOR shall keep fully informed of, and shall at all times during the Term (defined below) ensure the performance of the Work is in compliance with, all laws, statutes, ordinances, decrees, orders, and regulations which do or may affect the Project, performance of the Work, the materials used therein, or persons engaged in connection therewith, and all such orders of bodies and tribunals having any jurisdiction over same (collectively, “Applicable Laws”). If CONTRACTOR has reason to believe that any provision of the Contract Documents conflict with any Applicable Law(s), the CONTRACTOR shall immediately report same to the County Representative in writing. CONTRACTOR shall at all times observe and comply with, and shall cause all agents, employees, and subcontractors to observe and comply with, all Applicable Laws. CONTRACTOR acknowledges and shall comply with the provisions of Sections 9364 and Sections 9550 and 9566, inclusive, of the Civil Code of California.

9. **PAYMENTS NOT ACCEPTANCE**: No certificate given or payments made under this Contract, except the final payment hereunder, shall be evidence of the performance of this Contract, either wholly or in part, against any claim upon CONTRACTOR. Final payment for the Work performed under this Contract shall not be made until the lapse of thirty (30) days after the Notice of Completion of the Work has been filed for record and no payment shall be construed to be acceptance of any defective Work or improper materials. CONTRACTOR agrees that the payment for final quantities due under this Contract and the payment of amounts due for any Work in accordance with this Contract shall release the COUNTY from any claims or liabilities on account of Work performed under this Contract, as the same may be amended from time to time during the Term. In addition to guarantees required elsewhere, CONTRACTOR shall and does hereby guarantee all workmanship and material to be free of defects and fit for the purposes intended for a period of one year from and after both the date of acceptance of the work and the recordation of the Notice of Completion by the COUNTY and CONTRACTOR shall repair or replace all Work and materials, together with any other portions of the Work which may be displaced in so doing, that, in the opinion of the County Representative, is or becomes defective during the period of said guarantee, without expense whatsoever to the COUNTY.

10. **PREVAILING WAGE RATES**: Rates of wages, including overtime, holiday, and Sunday rates provided for the Work shall comply with and are subject to the California Labor Code, Sections 1770 et. seq., Executive Orders of the President of the United States No. 9240, dated September 9, 1942, and No. 9250, dated October 3, 1942, and to any modifications thereof, and to any orders of the President or any authorized Federal Officer or agency, insofar as the same may apply to this Contract.

No contractor or subcontractor may be listed on a bid for a public works project unless registered with the Department of Industrial Relations pursuant to Labor Code section 1725.5 [with limited exceptions from this requirement for bid purposes only under Labor Code section 1771.1(a)]. No contractor or subcontractor may be awarded a contract for public work on a public works project unless registered with the Department of Industrial Relations pursuant to Labor Code section 1725.5. This Project is subject to compliance monitoring and enforcement by the Department of Industrial Relations.

11. **CONTRACT DOCUMENTS ACKNOWLEDGED**: CONTRACTOR hereby declares that CONTRACTOR has read the Contract Documents, has carefully examined the plans and detailed drawings of the Work to be performed, and fully understands the intent and meaning of the same.

12. **TIME FOR COMMENCEMENT, COMPLETION**: The term of this Contract shall commence effective as of the first date that this Agreement is duly executed by all of the parties hereto (“Effective Date”) and shall terminate on the date that is 365 calendar days after the Effective Date unless earlier terminated in accordance with the provisions of this Agreement (“Term”). As soon as practicable after the Contract has been executed by both the CONTRACTOR and the COUNTY, a Notice to Proceed will be issued by the County Representative stating the starting date of work performance under the Contract (“Work Start Date”). CONTRACTOR shall complete all Work specified in the Contract Documents within 300 calendar days after the Work Start Date (“Contract Time” as that term is used in the General Conditions). The provisions of this Agreement pertaining to Liquidated Damages shall apply in the event of the CONTRACTOR's failure to complete the Work within the Contract Time. In the event that CONTRACTOR does not complete the Work during the Term, CONTRACTOR shall only be paid for the Work actually performed during the Term and accepted by COUNTY in accordance with the provisions of this Agreement.

13. **WORKERS' COMPENSATION INSURANCE**: CONTRACTOR certifies that CONTRACTOR has knowledge of, is in

compliance with, and warrants that CONTRACTOR at all times during the Term shall remain in compliance with, the provisions of Section 3700 of the Labor Code, which requires every employer to be insured against liability for Workers' Compensation or to undertake self-insurance by the provisions of that Code. CONTRACTOR shall comply with such provisions before commencing the performance of the Work.

14. PROGRESS PAYMENT; NO WAIVER FOR DELAY: Any progress payment made after the scheduled completion date for the Work shall not constitute a waiver of any liquidated damages under this Contract.

15. GUARANTEE BONDS: Before any performance under this Contract, the CONTRACTOR shall provide the security required by statute for the payment of all workers and suppliers, and security for the faithful performance of all terms and conditions of this Contract, in an amount and form approved by the COUNTY. Both securities shall contain provisions that automatically increase amounts thereof and/or time of completion or both for all change orders, extensions, and additions to the Work provided under this Contract.

16. DISPUTES: Should any dispute(s) arise respecting the construction or meaning of any of the plans or specifications affecting the Work or respecting the true value of any extra work or work omitted, such dispute(s) shall be resolved by the Director of the COUNTY's General Services Department or his Assistant Director of General Services designee ("Director"), whose decision shall be final and binding upon the parties hereto. If, after the decision of the Director as provided herein, claims (as defined in Public Contracts Code Section 20104) under this Contract are filed by CONTRACTOR against COUNTY, and those claims are in the aggregate amount of \$375,000 or less, such claims shall be resolved under Public Contracts Code Sections 20104 through 20104.8, inclusive.

17. SURVIVAL: All provisions of this Contract which by their nature are intended to survive the termination or expiration of this Agreement shall survive such termination or expiration.

18. INDEMNIFICATION AND INSURANCE: CONTRACTOR shall at all times comply with the indemnification and insurance provisions set forth in EXHIBIT C, attached hereto and incorporated herein by reference.

19. TAXES: CONTRACTOR shall pay all taxes, levies, duties, and assessments of every nature due in connection with any Work under this Contract and shall make any and all payroll deductions required by law. CONTRACTOR is responsible for all CONTRACTOR personnel and for the payment of their compensation, including, if applicable, withholding of income taxes, and the payment and withholding of social security and other payroll taxes, unemployment insurance, workers' compensation insurance payments, and disability benefits. In no event shall COUNTY pay or be responsible for any taxes imposed on, or with respect to, CONTRACTOR's income, revenues, gross receipts, personnel, real or personal property, or other assets. COUNTY shall not be responsible for paying any taxes on CONTRACTOR's behalf, and should COUNTY be required to do so by state, federal, or local taxing agencies, CONTRACTOR agrees to promptly reimburse COUNTY for the full value of such paid taxes plus interest and penalty, if any. These taxes shall include, but not be limited to, the following: FICA (Social Security), unemployment insurance contributions, income tax, disability insurance, and workers' compensation insurance.

20. CONFLICT OF INTEREST: CONTRACTOR covenants that CONTRACTOR presently has no employment or interest and shall not acquire any employment or interest, direct or indirect, including any interest in any business, property, or source of income, which would conflict in any manner or degree with the performance of Work required to be performed under this Contract. CONTRACTOR further covenants that in the performance of this Contract, no person having any such interest shall be employed by CONTRACTOR. CONTRACTOR must promptly disclose to COUNTY, in writing, any potential conflict of interest. COUNTY retains the right to waive a conflict of interest disclosed by CONTRACTOR if COUNTY determines it to be immaterial, and such waiver is only effective if provided by COUNTY to CONTRACTOR in writing.

21. NONDISCRIMINATION: COUNTY hereby notifies CONTRACTOR that COUNTY's Unlawful Discrimination Ordinance (Article XIII of Chapter 2 of the Santa Barbara County Code) applies to this Contract and is incorporated herein by this reference with the same force and effect as if the ordinance were specifically set out herein and CONTRACTOR agrees to comply with said ordinance.

22. NON-ASSIGNMENT: CONTRACTOR shall not assign, subcontract, delegate, or otherwise transfer, directly or indirectly, whether by operation of law or otherwise ("Transfer") this Contract, in whole or in part, or any of CONTRACTOR's rights or obligations under this Contract, without the prior written consent of COUNTY in each instance. Any attempted or purported Transfer in violation of this Section 24, or in violation of Section 2.08 of the General Conditions, attached hereto as part of Exhibit A, shall be null and void and without legal effect and shall constitute grounds for termination by COUNTY. No Transfer shall relieve CONTRACTOR of any of its obligations hereunder.

23. SEVERABILITY: If any one or more of the provisions contained in the Contract shall for any reason be held to be invalid, illegal or unenforceable in any respect by a court of competent jurisdiction, then such provision or provisions shall be deemed severable from the remaining provisions hereof, and such invalidity, illegality or unenforceability shall not affect any other

provision hereof, and this Contract shall be construed as if such invalid, illegal or unenforceable provision had never been contained herein.

- 24. TIME IS OF THE ESSENCE:** Time is of the essence in this Contract, and each covenant and term is a condition herein.
- 25. ENTIRE AGREEMENT AND AMENDMENT:** The Contract Documents, as may be modified from time to time during the Term by duly authorized and executed Change Orders in accordance with the provisions of this Agreement and the General Terms, contain the entire understanding and agreement of the Parties with respect to the subject matter hereof and thereof, and there have been no promises, representations, agreements, warranties or undertakings by any of the Parties, either oral or written, of any character or nature hereafter binding except as set forth herein and therein. This Contract may be altered, amended or modified only by an instrument in writing, duly executed by each of the Parties, and by no other means, except as otherwise set forth in Section 30, below, to the extent such delegated authority is expressly authorized by the COUNTY Board of Supervisors in approving this Contract. Each Party waives its future right to claim, contest or assert that this Agreement was modified, canceled, superseded, or changed by any oral agreements, course of conduct, waiver or estoppel.
- 26. EXECUTION OF COUNTERPARTS:** This Contract may be executed electronically and in any number of counterparts, and each of such counterparts shall for all purposes be deemed to be an original; and all such counterparts, or as many of them as the Parties shall preserve undestroyed, shall together constitute one and the same instrument.
- 27. SUBCONTRACTORS:** CONTRACTOR is authorized to subcontract with only the subcontractor(s) identified in the Bid as attached hereto and as set forth in Exhibit B (“Subcontractors”). Contractor shall be fully responsible for all services and Work performed by its Subcontractors. Contractor shall secure from each of its Subcontractors legally binding written agreements to comply with the provisions of this Agreement pertaining to CONTRACTOR’s obligations as if such obligations pertained to such Subcontractor, including, but not limited to, audit obligations.
- 28. CHANGE ORDERS:** No Change Order shall be valid or enforceable against the COUNTY unless in the form of the Form of Change Order attached here as Exhibit “E” and duly executed by both CONTRACTOR and the Director. in accordance with this Section 30 and Article 13 of the General Conditions (“Change Order”).
- 29. FLEET REQUIREMENTS:** Vehicles with a Gross vehicle weight rating (“GVWR”) greater than 8,500 lbs. and light-duty package delivery vehicles operated in California may be subject to the California Air Resources Board (“CARB”) Advanced Clean Fleets regulations. Such vehicles may therefore be subject to requirements to reduce emissions of air pollutants. For more information, please visit the CARB Advanced Clean Fleets webpage at <https://ww2.arb.ca.gov/our-work/programs/advanced-clean-fleets>. Contractor shall at all times have a valid Certificate of Reported Compliance, as described in section 2449(n) of Title 13 of the California Code of Regulations (“CARB Certificate of Compliance”), and shall confirm that each subcontractor listed in Contractor’s Bid has a valid CARB Certificate of Compliance, for each fleet of vehicles subject to 13 CCR section 2449 that may be used in performance of this Contract. No such vehicle is permitted on the project site unless and until Contractor provides County with a valid Certificate of Reported Compliance applicable to such vehicle.
- 30. ORDER OF PRECEDENCE:** In the event of conflict between the provisions contained in the numbered sections 1 through 34 of this Agreement (“Numbered Section”) and the provisions contained in the Exhibits, the provisions contained in the Numbered Sections of this Agreement shall prevail over those in the Exhibits other than Exhibit C, which Exhibit C shall control and prevail over all other provisions of this Contract. CONTRACTOR agrees that in the event of any discrepancy, inconsistency, gap, ambiguity, or conflicting language between the Bid attached hereto as Exhibit B, on the one hand, and any other provision(s) of this Contract on the other, the provisions of this Contract (including the Numbered Sections of this Agreement, Exhibit A, and Exhibit C) other than Exhibit B shall take precedence and control and prevail over the provisions of the Bid attached hereto as Exhibit B.
- 31. TERMINATION.**
- A. COUNTY may, by written notice to CONTRACTOR, terminate this Contract in whole or in part at any time, whether for COUNTY’s convenience, for nonappropriation of funds, or because of the failure of CONTRACTOR to fulfill its obligations hereunder.
 1. **For Convenience.** COUNTY may terminate this Contract in whole or in part upon thirty (30) days’ written notice. During such thirty (30) day period, CONTRACTOR shall, as directed by COUNTY, wind down and cease Work as quickly and efficiently as reasonably possible, without performing unnecessary services or activities and by minimizing negative effects on COUNTY from such winding down and cessation of Work.
 2. **For Nonappropriation of Funds.** Notwithstanding any other provision of this Contract, in the event that no funds or insufficient funds are appropriated or budgeted by federal, State or COUNTY governments, or sufficient funds are not otherwise available for payments hereunder in the fiscal year(s) covered by the Term of this

Agreement, then COUNTY will notify CONTRACTOR of such occurrence, and COUNTY may terminate or suspend this Contract in whole or in part, with or without a prior notice period. Subsequent to termination of this Contract under this provision, COUNTY shall have no obligation to make payments with regard to the remainder of the Term.

3. **For Cause.** Should CONTRACTOR default in the performance of this Contract or materially breach any of the provisions hereof, COUNTY may, at COUNTY's sole option, terminate or suspend this Contract in whole or in part upon written notice ("Termination Notice"). Upon receipt of such Termination Notice, CONTRACTOR shall immediately discontinue all Work (unless otherwise directed in such Termination Notice) and notify COUNTY in writing of the status of CONTRACTOR's performance of Work hereunder. The date of termination shall be the date the Termination Notice is received by CONTRACTOR, unless the Termination Notice directs otherwise.
- B. Upon termination, CONTRACTOR shall deliver to COUNTY all data, estimates, graphs, summaries, reports, and all other property, records, documents or papers as may have been accumulated or produced by CONTRACTOR in performing this Contract, whether completed or in process, except such items as COUNTY may, by written permission, permit CONTRACTOR to retain. Notwithstanding any other payment provision of this Contract, COUNTY shall pay CONTRACTOR for satisfactory Work performed as of the date of termination to include a prorated amount of compensation due hereunder less payments, if any, previously made. In no event shall CONTRACTOR be paid an amount in excess of the Maximum Contract Amount, or for unperformed portions of Work. CONTRACTOR shall furnish to COUNTY such financial information as in the judgment of COUNTY is necessary to determine the reasonable value of the Work rendered by CONTRACTOR. The foregoing is cumulative and shall not affect any right or remedy which COUNTY may have in law or equity.

32. **JURISDICTION; VENUE.** This Contract shall be governed by the laws of the State of California. Any litigation arising out of this Contract shall be filed in the County of Santa Barbara, if in state court, or in the federal district court nearest to the County of Santa Barbara, if in federal court.

33. **NO WAIVER.** COUNTY's delay or failure to act with respect to a breach of this Contract by CONTRACTOR shall not constitute or be construed as a waiver of COUNTY's rights with respect to subsequent or similar breaches. Any delay or failure of COUNTY to exercise or enforce any right or provision of this Contract shall not constitute a waiver of such right or provision, and every power and remedy given by this Contract to COUNTY shall be exercised from time to time and as often as may be deemed expedient in the sole discretion of COUNTY. No remedy herein conferred upon or reserved to COUNTY is intended to be exclusive of any other remedy or remedies, and each and every such remedy, to the extent permitted by law, shall be cumulative and in addition to any other remedy given hereunder or now or hereafter existing at law or in equity or otherwise.

34. **SIGNATORY AUTHORITY.** Each of the Parties hereby represents and warrants to the other Party that:

- (a) Such Party has the full right, power, and authority to enter into this Contract and to perform its obligations hereunder.
- (b) The execution of this Contract by the individual whose signature is set forth at the end of this Agreement on behalf of such Party, and the delivery of this Contract by such Party, have been duly authorized by all necessary corporate or other action on the part of such Party.
- (c) This Contract has been executed and delivered by such Party and (assuming due authorization, execution, and delivery by the other Party) constitutes the legal, valid, and binding obligation of such Party, enforceable against such Party in accordance with its provisions.

IN WITNESS WHEREOF, the parties hereto have executed this Agreement to be effective as of the first date fully executed by all of the parties hereto.

COUNTY
County of Santa Barbara

By: _____
LAURA CAPPS, CHAIR
BOARD OF SUPERVISORS

Dated: _____

ATTEST:
MONA MIYASATO,

CONTRACTOR

{LEGAL NAME OF CONTRACTOR}, a California corporation

COUNTY EXECUTIVE OFFICER

CLERK OF THE BOARD

By: _____
Deputy Clerk of the Board

By: _____
AUTHORIZED REPRESENTATIVE
Name: {NAME}

Title: {TITLE OF AUTHORIZED REPRESENTATIVE}

APPROVED AS TO FORM:
RACHEL VAN MULLEM,
COUNTY COUNSEL

APPROVED AS TO ACCOUNTING FORM:
BETSY SCHAFFER, CPA, CPFO
AUDITOR-CONTROLLER

By: _____
Deputy County Counsel

By: _____
Deputy Auditor-Controller

APPROVED AS TO FORM:
GREG MILLIGAN, ARM
RISK MANAGER

RECOMMENDED FOR APPROVAL
KIRK LAGERQUIST, DIRECTOR
GENERAL SERVICES DEPARTMENT

By: _____
Risk Management

By: _____
Department Head

Dept 067 Fund 1919 Program 8200 Account 3100 Project 22039

TERMS & CONDITIONS

SPECIAL CONDITIONS

NOTICE TO PROCEED

An official Notice to Proceed stating the first working day will be e-mailed to the CONTRACTOR who is awarded the bid. After Notice to Proceed is given, the CONTRACTOR agrees to complete the work within the Construction stipulated in the Notice to Bidders.

PRECONSTRUCTION CONFERENCE

Prior to commencing work, a preconstruction conference shall be held at the site between the CONTRACTOR and the COUNTY.

Excavation Protection: The Contractor at its sole expense shall provide and maintain fencing, shoring and bracing and dewatering of all excavations.

Temporary Safety Measures: The Contractor at its sole expense shall provide, maintain and remove when no longer required all temporary safety measures, including all construction supplies, barricades, pedestrian walkways and equipment as may be required by the Contract Documents for its Work.

Access Roads and parking lot: Contractor is responsible for keeping the access roads free from construction debris and dust. Access roads shall not be compromised by contractors' operations.

Construction Notification Signage:

The contractor shall provide and install construction notification /information signage to be installed in two separate locations as designated by the Owner's Authorized Representative. The signage will be installed on the access road and will include project contact information. At the completion of the project, the Contractor will be responsible for the removal of the temporary signage.

Traffic Control:

Temporary traffic control, including flagging, apparel, temporary traffic control devices, and equipment for flaggers, must comply with the California MUTCD, Part 6, "Temporary Traffic Control." Contractor must submit a traffic control plan identifying placement of flaggers and temporary traffic control devices and equipment for review and approval by the County. Additional conditions are found in Article 16.4.2 of the General Conditions.

Utility Work and electrical cut-over:

Contractor shall notify Owner's Representative at least one week in advance of all utility disruptions. Work will need to be scheduled for minimum disruption to the homes and buildings served by those utilities.

Disruptions:

The Contractor must coordinate all work activities in compliance with the contract documents. The contractor shall notify the Owner's Representative in advance of any planned abnormally loud construction activities. The Contractor will be required to coordinate work with the neighbors, so not to disrupt the daily functions of traffic going uphill to the project. Work must be pre-arranged with a minimum of 48-hour notice to the designated representative and the neighbors.

Hours of Operations:

Work hours should be from 8:00 am to 4:00 pm. Any work performed outside of these hours will need 48-hour notice and approval by the County. **NOTE: This is in a residential neighborhood**

Parking:

Contractor workers will be permitted to park at the designated construction staging areas.

Access:

Notwithstanding any of the contract provisions, the contractor must maintain safe access to all roads, parking lots, driveways, homes, buildings, ancillary structures and pedestrian routes throughout the duration of the project.

All contractor personnel shall carry appropriate identifying marks on clothing and/or identification cards. Contractor personnel shall not enter secure facilities without having appropriate approval and clearance by County. Contractor personnel shall not enter areas or workspaces where confidential documents are stored without proper clearance and be accompanied by a designated County of Santa Barbara employee.

GENERAL CONDITIONS

General Conditions

**County of Santa Barbara
Fire Station 7 Communication Complex
2411 Stanwood Drive
Santa Barbara, CA 93103
Project 22039**

February 2023

GENERAL CONDITIONS

Table of Contents

CONTRACT DOCUMENTS	5
1.1 DEFINITIONS	5
1.2 ABBREVIATIONS.....	6
1.3 EXECUTION, CORRELATION AND INTENT	6
1.4 OWNERSHIP AND USE OF DOCUMENTS.....	7
 OWNER	 7
2.1 DEFINITION	7
2.2 INFORMATION AND SERVICES FURNISHED BY THE OWNER.....	7
2.3 DELEGATION.....	7
2.4 AUTHORITY OF BOARD AND INSPECTION	8
 ARCHITECT/ENGINEER	 8
3.1 DEFINITIONS	8
3.2 ARCHITECT/ENGINEER'S DUTIES DURING CONSTRUCTION	8
 DESIGNATED REPRESENTATIVE	 10
4.1 DEFINITION	10
4.2 ADMINISTRATION OF THE CONTRACT	10
4.3 OWNER'S AND DESIGNATED REPRESENTATIVE'S RIGHT TO STOP WORK	11
 CONTRACTOR.....	 11
5.1 DEFINITION	11
5.2 REVIEW OF CONTRACT DOCUMENTS	12
5.3 SUPERVISION AND CONSTRUCTION PROCEDURES	12
5.4 LABOR AND MATERIALS.....	12
5.5 WARRANTIES AND GUARANTEES	14
5.6 CONTROL OF OPERATIONS AND EMPLOYEES.....	15
5.7 PERMITS, FEES AND NOTICES.....	16
5.8 ALLOWANCES.....	16
5.9 SUPERINTENDENT.....	16
5.10 CONSTRUCTION SCHEDULE	17
Submission of Schedule and Format	17
Updating of the Schedule	18

Revision of the Schedule	18
Minor Changes of the Schedule	18
Extensions of Contract Time	18
During Construction	18
Owner Directed Schedule	19
5.11 SUBMITTAL SCHEDULE.....	19
5.12 DRAWINGS AND SPECIFICATIONS AT THE SITE.....	20
5.13 USE OF SITE.....	20
5.14 CUTTING AND PATCHING WORK.....	20
5.15 DAILY AND FINAL CLEAN UP	21
5.16 COMMUNICATIONS.....	21
5.17 ROYALTIES AND PATENTS	21
5.18 INSURANCE.....	21
Insurance Requirements for Contractor	21
Subcontractors	22
5.19 CONTRACTOR QUALITY CONTROL SYSTEM	22
5.21 WARRANTY OF CONSTRUCTION.....	25
5.22 SUBCONTRACTS.....	26
5.23 LAWS TO BE OBSERVED	26
SUBCONTRACTORS	27
6.1 DEFINITION	27
6.2 SUB-CONTRACTUAL RELATIONS	27
SEPARATE CONTRACTS.....	27
7.1 OTHER CONTRACTORS.....	27
7.2 CONTRACTOR TO INSPECT OTHER WORK	27
7.3 COORDINATION AND COOPERATION.....	27
7.4 OWNER'S RIGHT TO CLEAN UP	28
7.5 DAMAGES TO WORK.....	28
MISCELLANEOUS PROVISIONS	28
8.1 GOVERNING LAW	29
8.2 SUCCESSORS AND ASSIGNS.....	29
8.3 WRITTEN NOTICE	29
8.4 CLAIMS FOR DAMAGES.....	29
8.5 PERFORMANCE BOND AND LABOR MATERIAL PAYMENT	
BOND 29	
8.6 RIGHTS AND REMEDIES.....	29
8.7 TESTS	29
8.8 ORDER OF PRECEDENCE.....	31
TIME 31	
9.1 DEFINITIONS.....	31
9.2 PROGRESS AND COMPLETION.....	31
9.3 DELAYS AND EXTENSIONS OF TIME	32

PAYMENTS AND COMPLETION	33
10.1 CONTRACT SUM.....	33
10.2 SCHEDULE OF VALUES	33
10.3 APPLICATION FOR PAYMENT	33
10.4 PROGRESS PAYMENTS.....	34
10.5 PAYMENTS WITHHELD	35
10.6 FAILURE OF PAYMENT.....	35
10.7 SUBSTANTIAL COMPLETION	35
10.8 FINAL COMPLETION AND FINAL PAYMENT	36
10.9 MEASUREMENT OF QUANTITIES FOR UNIT PRICE WORK.....	37
PROTECTION OF PERSONS AND PROPERTY.....	37
11.1 SAFETY PRECAUTIONS AND PROGRAMS.....	37
11.2 SAFETY OF PERSONS AND PROPERTY.....	38
11.3 EMERGENCIES	39
UTILITIES.....	39
12.1 LOCATION	39
12.2 PROTECTION	39
12.3 EXCAVATIONS	40
12.4 REMOVAL	40
12.5 RELOCATION	40
12.6 DELAYS.....	40
12.7 COOPERATION	41
CHANGES IN THE WORK.....	41
13.1 CHANGE ORDERS	41
13.2 CONCEALED CONDITIONS.....	43
13.3 CLAIMS FOR ADDITIONAL COST	43
13.4 MINOR CHANGES IN THE WORK.....	43
UNCOVERING AND CORRECTION OF WORK.....	44
14.1 UNCOVERING OF WORK.....	44
14.2 CORRECTION OF WORK.....	44
14.3 ACCEPTANCE OF DEFECTIVE OR NONCONFORMING WORK	44
TERMINATION OF THE CONTRACT	45
15.1 TERMINATION BY THE CONTRACTOR.....	45
15.2 TERMINATION BY THE OWNER	45
PROJECT REQUIREMENTS.....	45
16.1 PROJECT REPORTS	45
16.2 DRAWINGS, PRODUCT DATA AND SAMPLES	46

16.3	TEMPORARY SERVICES, SYSTEMS AND FACILITIES	49
16.4	SAFETY	52

ARTICLE 1: CONTRACT DOCUMENTS

1.1 DEFINITIONS

- 1.1.1 The Contract Documents: The Contract Documents consist of the Agreement between the Owner and the Contractor, the Conditions of the Contract (General Conditions, General Requirements, Special Provisions and other Conditions), the Drawings, the Specifications, all Addenda, Supplements, Invitations to Bid and Proposal Forms issued prior to execution of the Contract and all Modifications issued after the execution of the Contract. A Modification is (1) a written amendment to the Contract signed by both parties (2) a Change Order, (3) a written interpretation issued by the Architect/Engineer pursuant to Subparagraph 3.2.2 or (4) a written order for a minor change in the Work issued on the Owner's behalf pursuant to Paragraph 13.4.1.
- 1.1.2 The Contract: The Contract Documents form the Contract with the Contractor. This Contract represents the entire and integrated agreement and supersedes all prior negotiations, representations, or agreements, either written or oral. The Contract may be amended or modified only by a Modification as defined in Subparagraph 1.1.1. The Contract Documents shall not be construed to create any contractual relationship of any kind between the Architect/Engineer and the Contractor or between the Architect/Engineer and the Designated Representative but the Architect/Engineer and the Designated Representative shall be entitled to performance of the obligations of the Contractor intended for their benefit and to enforcement thereof. Nothing contained in the Contract Documents shall create any contractual relationship between the Owner, the Designated Representative or the Architect/Engineer and any Subcontractor or Sub-subcontractor.
- 1.1.3 The Work: The term "Work" means the construction and services required by the Contract Documents, whether completed or partially completed, and includes all other labor, materials, equipment and services provided or to be provided by the Contractor to fulfill the Contractor's obligations. The Work may constitute the whole or part of the project.
- 1.1.4 The Project: The "Project" is the total construction of which the Work performed under the Contract Documents may be the whole or a part and which may include construction by the Owner or by separate contractors.
- 1.1.5 The Owner: As defined in Article 2 of the General Conditions, the Owner for this project is: Santa Barbara County, through its Board of Supervisors
- 1.1.6 Architect/Engineer: As defined in Article 3 of the General Conditions.
- 1.1.7 Designated Representative: As defined in Article 4 of the General Conditions, the Designated Representative is also the Labor Compliance Coordinator for the Work.
- 1.1.8 Contractor: As defined in Article 5 of the General Conditions.
- 1.1.9 Product: The term "product" shall include materials, equipment and systems.
- 1.1.10 The Drawings: The Drawings are the graphic and pictorial portions of the Contract Documents, wherever located and whenever issued, showing the design, location and dimensions of the Work, generally including plans, elevations, sections, details, schedules, and diagrams.
- 1.1.11 The Specifications: The Specifications are that portion of the Contract Documents consisting of the written requirements for materials, equipment, construction systems, standards and workmanship for the Work and performance of related services.
- 1.1.12 The Bid Package: The Bid Package is the volume usually assembled for the Work which may include the bidding requirements, sample forms, conditions of the Contracts and Specifications.
- 1.1.13 As Approved: Where used in conjunction with the Designated Representative or the Architect/Engineer's response to submittal's, requests, applications, inquiries, reports and claims by the Contractor, the meaning of the term "approved" shall not exceed the limitations of the Designated Representative or the Architect/Engineer's responsibilities and duties as established in these General Conditions.
- 1.1.13.1 In no case shall "approval" by the Designated Representative or the Architect/Engineer be interpreted as a release of the Contractor from the responsibilities to fulfill the requirements of the Contract Documents.
- 1.1.13.2 Approval, where required for an item, shall be obtained from the Architect/Engineer through the Designated Representative in writing.
- 1.1.14 Indicated: The term "indicated" is a cross reference to details, notes or schedules on the drawings, other paragraphs

or schedules in the Specifications and similar means of recording requirements in the Contract Documents.

- 1.1.14.1 Where terms such as "shown", "noted", "scheduled", and "specified" are used instead of "indicated", it is for the purpose of helping the reader accomplish the cross reference and no limitation of locations is intended except as specifically noted.
- 1.1.14.2 Directed, Requested, Etc.: Where not otherwise explained, terms such as "directed", "requested", "authorized", "selected", "approved", "required", "accepted", and "permitted" mean "directed by the Architect/Engineer, Designated Representative or Owner's Representative", "requested by the Architect/Engineer, Designated Representative or the Owner's Representative", etc. However, no such implied meaning will be interpreted to extend to the Architect/Engineer's or Designated Representative's responsibility in the Contractor's area of construction supervision.
- 1.1.15 Installer: The person or entity engaged by the Contractor or its Subcontractor or Sub-subcontractor for the performance of a particular unit of Work at the project site, including installation, erection, application and similar required operations. It is a General Requirement that installers be recognized as experienced and competent in the Work that they are engaged to perform.
- 1.1.16 Suitable, Reasonable, Proper, Correct, and Necessary: Such terms shall mean as suitable, reasonable, proper, correct or necessary for the purpose intended as required by the Contract Documents, subject to the judgment of the Architect/Engineer or the Designated Representative.
- 1.1.17 Including, Such As: The Terms "including" and "such as" shall always be taken in the most inclusive sense, namely, "including, but not limited to", and "such as, but not limited to."
- 1.1.18 Option: The term "option" shall mean a choice from the specified products which shall be made by the Contractor. The choice is not "whether" the Work is to be performed, but "which" product or "which" procedure is to be used. The product or procedure chosen by the Contractor shall be provided at no increase in the cost to the Owner or the Designated Representative and with no lessening of the Contractor's responsibility for its performance. All or any options selected or proposed are still subject to all requirements for submittals and for approval of same.
- 1.1.19 Exposed: The term "exposed" shall mean any item or surface, exterior or interior, which can be seen by a person outside the building, or seen by a person inside any usable space within the building during normal activity.
- 1.1.20 At No Additional Cost: The term "at no additional cost" shall mean at no additional cost to the Owner and at no cost to the Architect/Engineer or the Designated Representative.
- 1.1.21 Testing Laboratory: An independent entity engaged to perform specific inspections or tests of the Work, either at the project site or elsewhere; and to report and interpret the results of those inspections or tests.
- 1.1.22 Record Documents: Construction Documents revised to show changes made during the construction process, usually based on marked-up prints, drawings and other data furnished by the Contractor to the Designated Representative.
- 1.1.23 Compliance Group Representative: The person or entity representing a third-party observer whose sole purpose on the PROJECT is to interview contractor employees, including any subcontractor for prevailing wage compliance consistent with federal and state prevailing wage requirements as set forth in the David-Bacon Act and other related codes, laws or regulations.

1.2 ABBREVIATIONS

- 1.2.1 The language of the specifications and elsewhere in the Contract Documents is of the abbreviated type in certain instances and implies words and meanings which will be appropriately interpreted.
- 1.2.2 Actual word abbreviations of a self-explanatory nature have been included in the Specifications and Drawings. These are generally defined in the Specifications Section at the first instance of use of each term so abbreviated. They are generally summarized in a list on the Drawings.
- 1.2.3 Singular words will be interpreted as plural and plural words will be interpreted as singular where applicable and the full context of the requirements so indicates.

1.3 EXECUTION, CORRELATION AND INTENT

- 1.3.1 By executing this Agreement, the Contractor represents that he has visited the site, familiarized himself with the local conditions under which the Work is to be performed and correlated its observations with the requirements of the Contract Documents. Claims, as a result of failure to do so, will not be considered.
- 1.3.2 The contract agreement shall be signed in triplicate by the Owner and Contractor. Original copies are to be provided to Owner, Contractor, and Designated Representative. Digital signatures, as of 2021, are acceptable by the County of Santa Barbara
- 1.3.3 The intent of the Contract Documents is to include all items necessary for the proper execution and completion of

the Work. The Contract Documents are complementary and what is required by any one shall be as binding as if required by all. Work not covered in the Contract Documents will not be required unless it is consistent therewith and is reasonably inferable therefrom as being necessary to produce the intended results. Words and abbreviations in the Contract Documents which have well-known technical or trade meanings are used in accordance with such recognized meanings.

- 1.3.4 The organization of the Specification into divisions, sections and articles and the arrangements of Drawings shall not control the Contractor in dividing the Work among Subcontractors or in establishing the extent of Work to be performed by any Trade.
- 1.3.5 All indications or notations which apply to one or a number of similar situations, materials or processes shall be deemed to apply to all such situations, materials or processes wherever they appear in the Work, unless otherwise indicated in the Contract Documents.
 - 1.3.5.1 Where the word "similar" appears on the drawings, it shall be interpreted in its general sense and not as meaning identical and all details shall be worked out in relations to their location and connection with other parts of the Work.
 - 1.3.5.2 Where, on any drawings, a portion of the Work is drawn out and the remainder is indicated in outline, the parts drawn out shall also apply to parts outlined.
- 1.3.6 All manufactured articles, materials and equipment shall be applied, installed, connected, erected, used, cleaned and conditioned in accordance with the manufacturer's written or printed directions and instructions unless otherwise indicated in the Contract Documents.
- 1.3.7 The Contract Documents should be read as one package and are dependent on one another for interpretation. If there is an ambiguity or conflict between documents, the Contractor or its Subcontractor has the duty of inquiring with the Designated Representative and the Architect/Engineer before he bids on the job. Conflicts and discrepancies discovered during the process of the Work shall be referred to the Architect/Engineer and Owner via the Designated Representative for resolution.
- 1.3.8 Any noted discrepancies between the Contract Documents shall be promptly called to the attention of the Designated Representative and the Architect/Engineer and no Work so affected shall be undertaken in advance of the Designated Representative's and the Architect/Engineer's decision, except at the Contractor's own risk.

1.4 OWNERSHIP AND USE OF DOCUMENTS

- 1.4.1 Unless otherwise provided in the Contract Documents, the Contractor will be furnished, free of charge, up to eight (8) sets of approved Working Drawings and Specifications for the execution of the Work.
- 1.4.2 All Drawings, Specifications and copies thereof furnished by the Owner are and shall remain its property. They are to be used only with respect to this project and are not to be used on any other project. With the exception of one contract set for each party, such documents are to be returned or suitably accounted for to the Owner on request at the completion of the Work.

ARTICLE 2: OWNER

2.1 DEFINITION

- 2.1.1 The Owner is the person or entity identified as such in the Agreement between the Owner and the Contractor and is referred to throughout the Contract Documents as if singular in number and masculine in gender. The term Owner means the Owner or its authorized representative.

2.2 INFORMATION AND SERVICES FURNISHED BY THE OWNER

- 2.2.1 The Owner will furnish all surveys describing the physical characteristics and approximate known utility locations for the site of the Project.
- 2.2.2 Except as provided in Subparagraph 5.7.1, the Owner will secure and pay for necessary approvals, easements, assessments and charges required for the construction, use, or occupancy of permanent structures or for permanent changes in existing facilities unless otherwise noted.
- 2.2.3 Information or services under the Owner's control will be furnished by the Owner with reasonable promptness to avoid delay in the orderly progress of the Work.
- 2.2.4 The Owner shall forward all instructions to the Contractor through the Designated Representative.
- 2.2.5 The Owner shall at all times have access to the Work for inspection, wherever it is in preparation or in progress. When directed by the Designated Representative, the Contractor shall provide facilities for such access and inspection at the Contractor's cost.

2.3 DELEGATION

- 2.3.1 The Board of Supervisors delegates to the County Director of General Services the authority to act on its behalf in the administration of this contract.
- 2.3.2 The Director of General Services has the authority to change the Designated Representative when the Designated Representative is an employee of the County.
- 2.3.3 If the Designated Representative is a person or entity other than an employee of the County, the Director of General Services shall recommend to the Board of Supervisors a replacement for the Designated Representative whenever such replacement is in the best interest of the County. An affirmative majority vote by the Board of Supervisors is required to complete the replacement of the Designated Representative.
- 2.3.4 The Director of General Services may execute Change Orders in accordance with Article 13 in a cumulative amount not to exceed 10% of the first \$250,000 of the base contract amount plus 5% of the base contract amount over \$250,000, and for time extensions as the director may deem equitable. Any Change Orders in excess of 10% of the first \$250,000 of the base contract amount plus 5% of the base contract amount over \$250,000 shall be approved by a majority vote of the Board of Supervisors.

2.4 AUTHORITY OF BOARD AND INSPECTION

- 2.4.1 The Board of Supervisors has the final authority in all matters affecting the work covered by the plans and specifications. Within the scope of the contract, the Designated Representative has the authority to enforce compliance with the plans and specifications. The Contractor shall promptly comply with instructions from the Designated Representative.
- 2.4.2 On all questions relating to quantities, the acceptability of material, equipment, or work, the execution, progress or sequence of work, and the interpretation of specifications or drawings, the decision of the Designated Representative is final and binding, and shall be precedent to any payment under the contract, unless otherwise ordered by the Board.
- 2.4.3 Labor Compliance Monitoring: To ensure compliance with prevailing wage requirements in the WORK, the Board of Supervisors has adopted a *Joint Labor Compliance Monitoring Program*. This program monitors labor compliance by conducting interviews with CONTRACTOR employees and subcontractors at the project site. A copy of the *Joint Labor Compliance Monitoring Program* is available at the Capital Projects Division Office. A copy of the *Joint Labor Compliance Monitoring Program* will be provided upon request. The Contractor, and all subcontractors, shall cooperate by allowing approved Compliance Group Representatives access to its employees on the project site for the purpose of conducting prevailing wage compliance interviews. The Compliance Group Representative shall restrict their on-site activities to prevailing wage compliance interviews only. Promotion, advertising or other related activities of the Compliance Group Representative is strictly prohibited. Any additional effort required by the Contractor in compliance with this Article shall be incorporated into the Bid Scope of Work and no additional compensation will be considered.
- 2.4.4 The Designated Representative (or its designee) may accompany any Compliance Group Representative when conducting prevailing wage compliance interviews. The Compliance Group Representative will display in plain view a county-issued identification card when conducting prevailing wage compliance interviews at the project site.

ARTICLE 3: ARCHITECT/ENGINEER

3.1 DEFINITIONS

- 3.1.1 The Architect/Engineer is the person lawfully licensed to practice architecture or engineering or an entity lawfully practicing architecture or engineering who has entered into an Agreement with the Owner to serve as Architect/Engineer and is referred to throughout the Contract Documents as if singular in number and masculine in gender. The term Architect/Engineer means the Architect/Engineer or its authorized representative.
- 3.1.2 Architect/Engineer shall be entitled to performance by the Contractor of any obligations expressly set forth which are intended for the Architect/Engineer's benefit and to enforcement thereof.
- 3.1.3 In the case of the termination of the employment of the Architect/Engineer, the Owner shall appoint a capable and reputable Architect/Engineer. The status under the Contract of the Architect/Engineer so appointed shall be that of the former Architect/Engineer. The Owner shall notify the Contractor whenever the Architect/Engineer is replaced.
- 3.1.4 The Architect/Engineer may be an employee of the County or other governmental entity.

3.2 ARCHITECT/ENGINEER'S DUTIES DURING CONSTRUCTION

- 3.2.1 The Architect/Engineer shall at all times have access to the Work wherever it is in preparation and progress. When directed by the Designated Representative, the Contractor shall provide facilities for such access at the Contractor's cost so the Architect/Engineer may perform its functions under the Contract Documents.
- 3.2.2 The Architect/Engineer will be the interpreter of the requirements of the Drawings and Specifications. Written

interpretations necessary for the proper execution or progress of the Work, in the form of drawings or otherwise, will be issued with reasonable promptness by the Architect/Engineer through the Designated Representative and in accordance with any schedule agreed upon. The Contractor or Owner shall make written request through the Designated Representative to the Architect/Engineer for such interpretations. Such interpretations shall be consistent with and reasonably inferable from the Contract Documents. The Contractor or Owner shall execute and complete the Work in accordance with such interpretations. The Architect/Engineer shall not be liable to the Contractor for the result of any interpretation or decisions rendered in good faith in such capacity.

- 3.2.2.1 The Architect/Engineer shall interpret the requirements of Change Orders and he shall decide all other questions of design intent in connection with the Work.
- 3.2.2.2 It shall be the responsibility of the Architect/Engineer to make interpretations and render opinions in regard to all claims to the Owner or Designated Representative involving questions of interpretation of the intent of the drawings and specifications. Such opinions and interpretations, together with the reasons therefore, shall be furnished in writing by the Architect/Engineer to the Owner, Designated Representative and Contractor within ten (10) days after a request is made thereof.
- 3.2.2.3 Neither the Contractor, the Designated Representative nor the Owner shall be bound by any determination, interpretation or opinion of the Architect/Engineer if it is determined that such is not in accord with the true intent of the Contract Documents. The party taking issue with the determination, interpretation, or decision of the Architect/Engineer shall give the other party or parties, as the case may be, written notice of such fact within ten (10) days after the determination, interpretation, or opinion is rendered by the Architect/Engineer. However, it is the intent of this Paragraph 3.2 that in the actual performance of the Work, the Contractor and the Designated Representative shall, in the first instance, proceed in accordance with the instruction given by the Architect/Engineer unless the Owner and the Designated Representative mutually agree that the Contractor and the Designated Representative shall proceed otherwise.
- 3.2.3 The Architect/Engineer's decisions in matters relating to artistic effect will be final if consistent with the intent of the Contract Documents.
- 3.2.4 The Architect/Engineer will have the authority to reject Work which does not conform to the Contract Documents. Whenever, in its opinion, he considers it necessary or advisable for the implementation of the intent of the Contract Documents, he will have authority to require special inspection or testing of the Work in accordance with Subparagraph 8.7.2 whether or not such Work be then fabricated, installed or completed. However, neither the Architect/Engineer's authority to act under this Subparagraph 3.2.4, nor any decision made by him in good faith either to exercise or not to exercise such authority, shall give rise to any duty or responsibility of the Architect/Engineer to the Contractor, any Subcontractor, any of their agents or employees, or any other person performing any of the Work.
- 3.2.4.1 The Architect/Engineer will be the judge of the performance of the Work and will use its powers under the Contract to enforce its faithful performance. The Architect/Engineer will determine the amount, quality, acceptability and fitness of all parts of the Work.
- 3.2.4.2 The Architect/Engineer will recommend suspension of the Work whenever suspension may be necessary to ensure the proper execution of the Work.
- 3.2.5 The Architect/Engineer will review and approve or take other appropriate action upon Contractor's submittals such as Shop Drawings, Product Data and Samples, but only for conformance with the design concept of the Work and with the information given in the Contract Documents. Such action shall be taken with reasonable promptness so as to cause no delay. The Architect/Engineer approval of a specific item shall not indicate approval of an assembly of which item is a component.
- 3.2.6 The Architect/Engineer along with the Designated Representative will conduct inspections to determine the dates of Substantial Completion and Final Completion and will receive and review written warranties and related documents required by the Contract and assembled by the Contractor.
- 3.2.7 Architect/Engineer shall prepare and deliver to the Owner a set of reproducible mylar record construction drawings and record construction specifications showing significant changes in the Work during the construction process based upon marked up prints of drawings and other data provided by the Contractor through the Designated Representative.
- 3.2.8 The Architect/Engineer will communicate with the Contractor through the Designated Representative.
- 3.2.9 The Architect/Engineer will visit the site at intervals appropriate to the stage of construction to become generally familiar with the progress and quality of Work and to determine in general if the Work is being performed in a manner indicating that the Work, when completed, will be in accordance with the Contract Documents. However, the Architect/Engineer will not be required to make exhaustive or continuous on-site inspections to check quality or quantity of the Work. On the basis of on-site observations as an Architect/Engineer, the Architect/Engineer will keep the Owner informed of progress of the Work and will endeavor to guard the Owner against defects and deficiencies in the Work.
- 3.2.10 The Architect/Engineer will not have control over or charge of and will not be responsible for construction means,

methods, techniques, sequences or procedures, or for safety precautions and programs in connection with the Work, since these are solely the Contractor's responsibility as provided in Paragraph 5.3. The Architect/Engineer will not be responsible for the Contractor's failure to carry out the Work in accordance with the Contract Documents. The Architect/Engineer will not have control or charge of and will not be responsible for acts or omissions of the Contractor, Subcontractor, or their agents or employees, or of any other persons performing portions of the Work.

- 3.2.11 The Architect/Engineer has no authority to issue change orders. All requests for proposals shall be prepared by the Architect/Engineer, shall be approved by the Owner or Director of General Services, and shall be issued to the Contractor through the Designated Representative.

ARTICLE 4: DESIGNATED REPRESENTATIVE

4.1 DEFINITION

- 4.1.1 The Designated Representative is the person or entity who has been identified in writing by the Owner to serve as Designated Representative and is referred to throughout the Contract Documents. When the Designated Representative is an entity, the term Designated Representative includes the Designated Representative acting through its authorized representatives as indicated to the Contractor in writing at the preconstruction meeting or whenever changes in personnel assignments occur.

4.2 ADMINISTRATION OF THE CONTRACT

- 4.2.1 The Designated Representative will provide, as the Owner's authorized representative, the general administration of the Project as herein described.
- 4.2.2 The Designated Representative will be the Owner's construction representative during the construction until final payment and shall have the responsibility to monitor the Work of the Contractor.
- 4.2.3 The Designated Representative shall monitor the Work to be performed through completion. The Designated Representative's activities shall in no way supersede or dilute the Contractor's obligation to perform the Work in conformance with all contract requirements, but s/he is empowered, by the Owner, to act on its behalf with respect to the proper execution of the Work and shall give instructions to require such corrective measures as may be necessary, in its opinion, to ensure the proper execution of the contract or to protect the Owner's interest. The Designated Representative shall have the authority to require prompt execution of Work whenever such action may be necessary, in its opinion, to ensure the proper execution of the Work or to protect the interests of the Owner. Except as otherwise provided herein, the Designated Representative shall determine the amount, quality, acceptability, fitness and progress of the Work covered by the Contract without, however, assuming any of the Architect/Engineer's statutory or customary obligations.
- 4.2.4 The Designated Representative shall be deemed to be the Owner's Representative to the extent set forth below and elsewhere in this Contract. The Designated Representative shall have no authority to obligate or otherwise bind the Owner.
- 4.2.5 The Designated Representative shall review and monitor the Contractor's Work and construction schedule and establish specific measures and actions which the Contractor shall take to maintain the current approved schedule.
- 4.2.6 The Designated Representative shall examine the Contractor's Work to determine if the construction conforms to the requirements of this Contract (provided, however, that such action by the Designated Representative shall not supersede or diminish the Contractor's obligation to furnish materials and perform the Work in conformity with all requirements of this Contract).
- 4.2.7 The Designated Representative shall determine any corrective measures which may be necessary to bring the Contractor's performance into conformity with Contract requirements.
- 4.2.8 The Designated Representative shall monitor the Contractor's performance in coordinating the Contractor's Work under this Contract with the Work being performed or to be performed by other separate contractors.
- 4.2.9 The Designated Representative shall assist the Owner and the Architect/Engineer in the resolution of questions of Contract interpretation. If the Contractor either disagrees with the Designated Representative's interpretation or considers that such interpretation constitutes a constructive change in Contract requirements, the question shall be referred to the Owner for contract interpretation.
- 4.2.10 The Designated Representative shall establish and recommend administrative procedures for coordinating the activities of the Contractor, the Designated Representative, the Architect/Engineer and the Owner.
- 4.2.11 The Designated Representative shall monitor the Contractor's submittal schedule.
- 4.2.12 The Designated Representative shall coordinate the activities of the Testing Agencies with the activities of the Contractor.
- 4.2.13 The Designated Representative shall review all requests or recommendations for changes affecting this Contract, review proposals, assist in negotiating and submit recommendations thereon to the Owner.

- 4.2.14 The Designated Representative shall make recommendations, together with the Architect/Engineer where appropriate, to the Owner as to the qualifications of Subcontractors or Suppliers wherever submittals of Subcontractors and Suppliers are required to be furnished under this contract.
- 4.2.15 The Designated Representative shall transmit to the Owner all written guarantees and warranties which the Contractor is required to furnish under this contract.
- 4.2.16 The Designated Representative may call meetings which shall be attended by the Contractor, Subcontractors and Material Suppliers, as the Designated Representative may deem necessary.
- 4.2.17 The Designated Representative shall have the authority to reject Work which does not conform to the Contract Documents and to require any Special Inspection and Testing in accordance with Subparagraph 8.7.2.
- 4.2.18 The Designated Representative shall review all applications by the Contractor for progress payments and final payment and make recommendations to the Architect/Engineer and Owner for approval thereof in accordance with the Owner's procedures.
- 4.2.19 The Designated Representative along with the Architect/Engineer will conduct inspections to determine the dates of Substantial Completion and Final Completion and will receive and review written warranties and related documents required by the Contract and assembled by the Contractor.
- 4.2.20 In the event any claim is made or any action brought in any way relating to the design or construction of the Project, the Designated Representative will render to the Owner any and all assistance required of it.
- 4.2.21 The Owner may, at his option, designate the Designated Representative as its representative to perform additional functions, including functions for which other authorized representatives may be designated by the provisions of this contract.
- 4.2.22 It shall be the duty of the Contractor to comply with all procedures established and implemented by the Designated Representative and approved by the Owner as stated above. In the event any such procedures are at a variance with other provisions of the Contract Documents, such procedures shall prevail.
- 4.2.23 The Designated Representative shall, at all times, have access to the Work wherever it is in preparation and progress. When directed by the Designated Representative, the Contractor shall provide facilities for such access so the Designated Representative may perform its functions under the Contract Documents.
- 4.2.24 In no event shall any act or omission on the part of the Designated Representative relieve the Contractor from its obligation to perform its Work in full compliance with the Contract.

4.3 OWNER'S AND DESIGNATED REPRESENTATIVE'S RIGHT TO STOP WORK

- 4.3.1 If the Contractor fails to correct defective Work as required by Paragraph 14.2 or persistently fails to carry out the Work in accordance with the Contract Documents, the Designated Representative or the Owner through the Designated Representative may order the Contractor to stop the Work, or any portion thereof, until the cause for such order has been eliminated.
- 4.3.1.1 The Contractor shall bear all costs of such Work stoppage unless it is determined that no fault existed in the Contractor's Work. Any Work stoppage for the correction of defective Work or removal and replacement of unacceptable materials and equipment will not be considered as the basis for any time extension.
- 4.3.2 If the Contractor defaults or neglects to carry out the Work in accordance with the Contract Document and fails within 48 hours after receipt of written notice from the Designated Representative to commence and continue correction of such default or neglect with diligence and promptness, the Designated Representative may, by written notice and without prejudice to any other remedy he or the Owner may have, make good such deficiencies. In such case an appropriate Change Order shall be issued deducting from the payments then or thereafter due the Contractor the cost of correcting such deficiencies, including compensation for the Architect/Engineer's and the Designated Representative's additional services made necessary by such default, neglect or failure.
- 4.3.3 The relationship of the Designated Representative to the Owner may be that of an independent contractor and the Designated Representative shall have no authority to bind the Owner in any way with the Contractor, its subcontractors, materials suppliers or any third parties.

ARTICLE 5: CONTRACTOR

5.1 DEFINITION

- 5.1.1 A Contractor is the person or entity identified as such in the Agreement between the Owner and a Contractor and is referred to throughout the Contract Document as if singular in number and masculine in gender. The term Contractor means the Contractor or its authorized representative.
-

5.1.2 It is the duty of the Contractor to comply with all procedures established and implemented by the Designated Representative and approved by the Owner as stated herein.

5.2 REVIEW OF CONTRACT DOCUMENTS

5.2.1 The Contractor shall carefully study and compare the Contract Documents, shall investigate existing site conditions, and shall at once report to the Designated Representative any error, inconsistency or omission he may or reasonably should discover.

5.2.2 All soil and test borehole data, water table elevations, and soil analyses shown on the drawings or included in the specifications apply only at the locations of the test holes and to the depths indicated. Soil test reports for the test holes which have been drilled are available for inspection at the office of the Director of General Services. Any additional subsurface exploration shall be done by bidders or the Contractor at their own expense.

5.2.3 The indicated elevation of the water table is that existing at the date the test hole was determined. It is the Contractor's responsibility to determine and allow for the elevation of groundwater at the date of project construction. A difference in elevations between groundwater shown in soil boring logs and groundwater actually encountered during construction will not be considered as a basis for extra work.

5.3 SUPERVISION AND CONSTRUCTION PROCEDURES

5.3.1 The Contractor shall supervise and direct the Work, using the best skill and attention. He shall be solely responsible for all construction means, methods, techniques, sequences and procedures and for coordinating all portions of the Work under the Contract.

5.3.1.1 The Designated Representative may reject any means, methods, techniques, sequences or procedures proposed by the Contractor, which might constitute or create a hazard to the Work or to persons or property, or which will not provide Work in accordance with the Contract Documents. However, neither the Designated Representative's acceptance of nor its failure to reject any means, methods, techniques, sequences and procedures shall relieve the Contractor of its responsibilities to safely and properly complete the Work.

5.3.2 The Contractor shall be responsible to the Owner and the Designated Representative for the acts and omissions of its employees and all its Subcontractors and their agents and employees and other persons performing any of the Work under a contract with the Contractor.

5.3.3 Neither observations, inspections, tests or approvals by persons other than the Contractor shall relieve the Contractor from its obligations to perform the Work in accordance with the Contract Documents.

5.3.4 The Contractor shall do and be responsible for the correct horizontal and vertical layout out and completion of the Work as per the drawings and written instruction of the Designated Representative including all necessary leveling and checking. The Contractor shall protect and preserve all permanent survey monuments or bench marks and shall bear the expense of replacing any that may be disturbed without permission of the Designated Representative. Replacement of damaged permanent survey monuments or benchmarks shall be performed by a licensed land surveyor hired by the Owner.

5.3.5 The Contractor shall keep the Designated Representative informed of the plan and progress of its Work. No Work shall be closed or covered until it has been duly inspected and approved. Should uninspected Work be covered, the Contractor shall, at its own expense, uncover all such Work so that it can be properly inspected; and after such inspection, he shall properly repair and replace all such Work.

5.4 LABOR AND MATERIALS

5.4.1 The Contractor shall provide and pay for all labor, equipment, tools, construction equipment and machinery, transportation and other facilities and services necessary for the proper execution and completion of the Work, whether temporary or permanent and whether or not incorporated or to be incorporated in the Work.

5.4.1.1 The Contractor shall accept delivery and store, protect and provide security for any Owner-purchased materials, systems and equipment which are a part of the Work until such items are incorporated into the Work. The Contractor shall document receipt of such materials, systems and equipment on forms acceptable to the Designated Representative.

5.4.1.2 The Contractor shall furnish, install, connect, make operable, and test all heating, ventilating and air conditioning equipment, plumbing fixtures, lighting fixtures, kitchen equipment, and any other mechanical or electrical equipment shown on the plans or called for in the specifications or change orders. In connection therewith, the Contractor shall also furnish and install all necessary devices, hardware, and systems required to make said equipment properly and safely operable including, but not limited to, mounting hardware and framing, insulation, vibration control devices, duct systems, gas piping systems, hot and cold-water systems, venting ducts, control systems, and electrical circuits.

5.4.1.3 The Contractor shall furnish and install complete utility systems ready for use and shall pay any special fees, permits or assessments required by the serving utility.

- 5.4.2 The Contractor shall at all times enforce strict discipline and good order among its employees and shall not employ on the Work any unfit person or anyone not skilled in the task assigned to him.
- 5.4.2.1 Any person employed, who is found to be incompetent, intemperate, troublesome, disorderly or otherwise objectionable, or who fails or refuses to perform its work properly and acceptably, shall be immediately removed from the work by the Contractor and not be re-employed on the work.
- 5.4.2.2 The Owner may remove and may order the Contractor to remove any person who is incompetent or otherwise objectionable from the site of the Work.
- 5.4.3 Approval of the Architect/Engineer under any substitution clause shall be obtained in writing before any substitution is made. In the event of the Contractor failing to obtain such approval, no consideration will be given to any appeal from the decision of the Architect/Engineer condemning any materials furnished.
- 5.4.4 Pursuant to the Public Contract Code, any reference in the specifications and plans to any brand name, article, device, product, materials, fixture, form or type of construction by brand name, make, or catalog number, such references shall be interpreted as establishing a standard of quality and shall not be construed as limiting competition; and the Contractor, in such cases, may at its option use any article, device, product, materials fixture, form or type of construction which in the judgment of the Architect/Engineer expressed in writing is equal to that specified. The Contractor must within forty (40) days after award of the Contract submit data substantiating a request for substitution.
- 5.4.5 If the Contractor proposed to use a material which, while suitable for the intended use, deviates in any way from the detailed requirements of the Contract Documents he shall inform the Architect/Engineer through the Designated Representative in writing of the nature of such deviations at the time that the materials are submitted for approval and shall request a written approval of the deviation from the requirements of the Contract Documents.
- 5.4.6 In requesting approval of deviations or substitutions, the Contractor shall provide evidence leading to a reasonable certainty that the proposed substitutions or deviation will provide a quality of result at least equal to that otherwise attainable. If, in the opinion of the Architect/Engineer, the evidence presented by the Contractor does not provide a sufficient basis for such reasonable certainty, the Architect/Engineer may reject such substitution or deviation without further investigation.
- 5.4.7 The Architect/Engineer will judge the design and appearance of proposed substitutes on the basis of their suitability in relation to the overall design of the project, as well as for their intrinsic merits. The Architect/Engineer will not approve proposed substitutes as equal to items specified which, in its opinion, would be unharmonious, or otherwise inconsistent with the character or quality of design of the project.
- 5.4.8 Any additional cost, or any loss or damage, arising from the substitution of any material or method for those originally specified or drawn shall be borne by the Contractor, notwithstanding approval or acceptance of such substitution by the Owner or Architect/Engineer, unless such substitution was made at the written request or direction of the Owner or Architect/Engineer.
- 5.4.9 The investigation, review and approval of substitute materials requires a minimum of 30 calendar days additional time more than for specified items. The Contractor is required to assure the time impact will not delay its or other Contractor's Work when submitting (proposing) a substitution. Submittal of a substitution will be promptly rejected if the Contractor does not accept the delay responsibility in making its submittal.
- 5.4.10 The Contractor, its agents and employees shall be bound by and comply with all applicable provisions of the California Labor Code, and with Federal, State, and local laws related to labor.
- 5.4.11 The Contractor shall strictly adhere to the provisions of the California Labor Code regarding minimum wages, the eight-hour day and the forty-hour week, overtime, Saturday, Sunday, and holiday work and non-discrimination because of race, color, national origin, religion, sex, age, or physically handicapped when otherwise qualified. The Contractor shall forfeit to the Owner the penalties prescribed in the California Labor Code for violations.
- 5.4.12 The Contractor, as required by the California Labor Code, sections 1770 et seq., the Contractor shall pay not less than the prevailing rate of per diem wages for each classification of worker employed as determined by the Director of the California Department of Industrial Relations. A copy of the general prevailing rate of per diem wages is available at the General Services Department to be viewed upon request. The Contractor shall post a copy of such wage determination at each job site.
- 5.4.13 As provided in Section 1775 of the California Labor Code, as a penalty, the Contractor shall forfeit twenty-five dollars (\$25.00) for each calendar day, or portion thereof, for each worker paid less than the prevailing rates for such work or craft in which such worker is employed for any public work done under the Contract by the Contractor or any Subcontractor under him.
- 5.4.14 The Contractor shall submit completed Payroll Reporting Forms for all Tradesmen employed on the Work with the monthly Progress Payment Application.
- 5.4.15 Payroll Reporting Forms shall be the forms prescribed by the Owner or computer-generated payroll reporting forms

which have been approved in writing by the Owner or the Designated Representative.

- 5.4.16 The Contractor's attention is directed to Sections 1777.5, 1777.6, and 1777.7 of the California Labor Code and Title 8, California Administrative Code Section 200 etseq.
- 5.4.17 To ensure compliance and complete understanding of the law regarding apprentices, and specifically the required ratio thereunder, the Contractor and Subcontractors should, where some question exists, contact the Division of Apprenticeship Standards prior to commencement of the Work. Responsibility for compliance with the law lies with the Contractor.
- 5.4.18 The Owner's policy is to encourage the employment and training of apprentices in its construction contracts as may be permitted under local apprenticeship standards.
- 5.4.19 As required by Section 1773.8 of the California Labor Code, the Contractor shall pay travel and subsistence payments to each worker needed to execute the Work, as such travel and subsistence payments are defined in the applicable collective bargaining agreements filed in accordance with this section.
- 5.4.20 To establish such travel and subsistence payments, the representative of any craft, classification, or type of workman needed to execute the Work shall file with the Department of Industrial Relations fully executed copies of collective bargaining agreements for the particular craft classification or type of work involved. Such agreements shall be filed within ten (10) days after their execution and thereafter shall establish such travel and subsistence payments whenever filed thirty (30) days prior to the call for bids.
- 5.4.21 The Contractor shall comply with all applicable provisions of Sections 1810 to 1815, inclusive of the California Labor Code relating to working hours. As a penalty, the Contractor shall forfeit twenty-five dollars (\$25.00) for each worker employed in the execution of the Work by the Contractor or by any Subcontractor for each calendar day during which such work is required or permitted to work more than eight (8) hours in any one calendar day and forty (40) hours in any one calendar week, unless such worker receives compensation for all hours worked in excess of these limits at not less than one and one half (1.5) times the basic rate of pay.

5.5 WARRANTIES AND GUARANTEES

- 5.5.1 The Contractor, prior to or at the time of Substantial Completion for the Work and during administrative closeout of the project, shall submit one (1) digital copy of all warranties and guarantees to the Designated Representative for subsequent transmittal to the Architect/Engineer and Owner. All guarantees and warranties shall be in writing on guarantors'/warrantors' stationery or official forms and signed by a responsible company official, and shall be submitted in full force and effect by the Contractor.
 - 5.5.1.1 The Contractor warrants to the Owner and the Designated Representative that all installed materials and equipment will be new unless otherwise specified and that all Work will be of good quality, free from faults and defects and in conformance with the Contract Documents. All Work not conforming to these requirements, including substitutions not properly approved or authorized, shall be considered defective unless specifically accepted by the Owner. If required by the Designated Representative, the Contractor shall furnish satisfactory evidence as to the kind and quality of materials and equipment. This warranty is not limited by the provisions of Paragraph 14.2.
 - 5.5.1.2 The warranty of materials, equipment and workmanship defined in 5.5.1 is separate from, independent of and in addition to any other guarantees in this contract or any other warranties required by the Contract Documents.
 - 5.5.1.3 Except as otherwise specified, all Work shall be guaranteed by the Contractor against defects resulting from the use of inferior materials, equipment or workmanship for one year from the date of Substantial Completion of the Project and acceptance/occupancy by the Owner in writing, provided that if prior to the acceptance of the entire project, the Owner occupies or uses any separate unit of Work, the guarantee period shall, as to the unit so occupied or used, commence on the date of such occupancy or use, with the further provision that the Owner shall have first agreed in writing that the separate unit shall be occupied or used by the Owner until such certificate has been given. Equipment and facilities, which have seasonal limitations on their operations, shall be guaranteed for one full year from the date of test and acceptance in writing by the Owner.
 - 5.5.1.4 If within any guarantee period, repairs or changes are required in connection the guaranteed Work, as the result of the use of materials, equipment or workmanship which are defective or inferior or not in accordance with the terms of the Contract, the Contractor shall, promptly, within 48 hours after receipt of notice from the Designated Representative or Owner and without expense to the Owner or the Designated Representative, commence and continue to affect such repairs or changes.
 - (a.) The Contractor shall place in satisfactory condition, in every particular, all of such guaranteed Work and correct all defects therein.
 - (b.) The Contractor shall make good all changes to the structure or site or equipment or contents thereof, which, in the opinion of the Architect/Engineer and the Designated Representative is the result of the use of materials, equipment or workmanship which are inferior, defective or not in accordance with the terms of the Contract. The Contractor shall make good any Work or materials, or the equipment and contents of structures or site disturbed in fulfilling such guarantee.

(c.) Notifications by Owner of defects shall stop the warranty time period. The guarantee or warranty period for that replaced or restored Work shall be reinstated for the remaining time period, starting on the date of acceptance of the replaced or restored Work.

- 5.5.1.5 In any case, where in fulfilling the requirement of the Contract or of any guarantee embraced in or required thereby, the Contractor disturbs any Work guaranteed under another contract, he shall restore such Work to a condition satisfactory to the Architect/Engineer and the Designated Representative and guarantee such restored Work to the same extent as it was guaranteed under such other contract.
- 5.5.1.6 If the Contractor, after notice, fails to proceed within 48 hours to commence and continue to comply with the terms of the guarantee, the Owner or Designated Representative may have the defect corrected in which case the Contractor and its surety shall be liable for all expenses incurred.
- 5.5.1.7 All special guarantees or warranties applicable to definite parts of the Work that may be stipulated in the Specifications or other papers forming a part of the Contract shall be subject to the terms of the Subparagraph 5.5.1.2 during the first year of the life of such special guarantee.
- 5.5.1.8 Nothing contained in Subparagraph 5.5.1 shall be construed to establish a period of limitation with respect to any other obligation which the Contractor might have under the Contract Documents, including liability for defective Work under Subparagraph 5.5.1. Subparagraph 5.5.1 relates to the specific obligation of the Contractor to correct the Work and does not limit the time within which its obligation to comply with the Contract Documents may be sought to be enforced, nor of the time within which proceedings may be commenced to establish the Contractor's Liability with respect to its other obligations under this contract.
- 5.5.1.9 In the event the Work of the Contractor is to be modified by another Contractor, either before or after the Inspection provided for in Subparagraph 10.7.1, the first Contractor shall remain responsible in all respects under the warranty given in Paragraph 5.5 and under any other warranties provided in the General Conditions or by law. However, the first Contractor shall not be responsible for any defects in materials or workmanship introduced by the Contractor modifying its Work. Both the first Contractor and the Contractor making the modifications shall be responsible solely for the Work done by each. The Contractor modifying the earlier Work shall be responsible for any damage to or defect introduced into the Work which it is modifying.
- 5.5.1.10 Warranties and guarantees shall clearly define what is to be guaranteed; the extent, terms, conditions, time and effective dates.
- 5.5.1.11 Copies of the same warranties and guarantees shall be included in the "Owner's Maintenance Manual" as specified herein.
- 5.5.2 The Owner shall schedule an end of warranty review meeting with the Designated Representative, Architect/Engineer, and Contractor prior to the end of one-year warranty to determine any work requiring correction.

5.6 CONTROL OF OPERATIONS AND EMPLOYEES

- 5.6.1 The Contractor shall not use any of the existing Owner's facilities, such as, but not limited to, toilets, cafeteria, parking areas, power hookup, except with the Owner's written approval.
- 5.6.2 The Contractor shall confine and perform its operations in those areas where construction is required. Contractor shall protect the contiguous non-construction property. The Contractor shall protect from damage all existing trees, utilities, or other improvements at the site. Should damage result from the Contractor's failure to exercise reasonable care in the performance of its Work, the Contractor shall repair or restore any such damage at its own expense.
- 5.6.3 Obnoxious behavior or possession or consumption of alcoholic beverages or drugs on the premises is strictly prohibited. Violators shall be promptly discharged from the site and may be subject to prosecution.
- 5.6.4 All vehicular aisles and walking paths at the site where Work under the Contract is being performed are for the general use and the Contractor's operations must conform to the Owners regulations and requirements to keep areas free of obstructions. If the Work of a Contractor requires that such aisles and paths be temporarily discontinued, after obtaining Designated Representative's approval, the Work shall be done expeditiously and alternate vehicular routes and paths of travel shall be identified by such Contractor and maintained as directed.
- 5.6.4.1 To minimize public inconvenience and possible hazards and to restore work areas to their original condition and former state of usefulness as soon as practicable, the Contractor shall diligently prosecute the work to completion. If, in the Designated Representative's opinion the Contractor fails to prosecute the work to the extent that the above purposes are not being accomplished, the Contractor shall, upon orders from the Designated Representative, immediately take the steps necessary to fully accomplish said purposes. All costs of prosecuting the work as described herein shall be borne by the Contractor. Should the Contractor fail to take the necessary steps to fully accomplish said purposes, after orders of the Designated Representative to do so, the Owner may suspend the work in whole or in part, until the Contractor takes said steps.
- 5.6.4.2 If work is suspended through no fault of the Owner, all expenses and losses incurred by the Contractor during such suspensions shall be borne by him. If the Contractor fails to properly provide for public safety, traffic, and protection

of the work during periods of suspension, the Owner may elect to do so, and deduct the cost thereof from monies due the Contractor. Such action will not relieve the Contractor from liability.

5.6.5 The Contractor shall not disturb any existing structure, piping, apparatus or other Work unless expressly required by the contract. Where cutting, drilling or removals are required in existing walls, floor or roof construction, the Work shall be done in such a manner to safeguard and not endanger the structure and shall in all cases be as approved by the Owner and Designated Representative. Prior to any cutting, drilling or removals, the Contractor shall investigate both sides of the surface involved, shall determine the exact location of adjacent structural members by visual examination and shall avoid interference with such members. No structural members, such as joists, beams or columns supporting Work that are to remain shall be cut, drilled or removed unless such conditions are shown in detail on the Drawings and reinforcing of members affected or new members to compensate for such cutting, drilling and removals are shown. If unforeseen obstructions are encountered, the Contractor shall take all precautions necessary to prevent damage and shall apply for and obtain full instructions from the Designated Representative, in writing, before proceeding with the Work.

5.6.6 Rights of way or easements for the improvement as shown on the plans will be provided by the Owner. Unless otherwise provided, the Contractor shall make its own arrangements, pay for, and assume all responsibility for acquiring, using, and disposing of additional work areas and facilities temporarily required by him. The Contractor shall indemnify and hold the Owner, Designated Representative, and Architect/Engineer harmless from all claims for damages occasioned by such actions.

5.6.7 The Contractor shall remove and dispose at no cost to the Owner and with the Owner's approval, existing improvements for which no specific disposition is made on the plans but which could interfere with the work.

5.7 PERMITS, FEES AND NOTICES

5.7.1 Unless otherwise provided in the Contract Documents, the Contractor shall secure and pay for all permits including encroachment permits, governmental fees, licenses and inspections necessary for the proper execution and completion of this Work, which are customarily secured after execution of the contract and which are legally required at the time bids or proposals are received.

5.7.1.1 The Project pays County Building Permit Fees.

5.7.1.2 The Owner will pay for building permits required by other governmental entities.

5.7.1.3 The Contractor shall sign for all building permits and shall be responsible for all inspections required.

5.7.2 The Contractor shall give all notices and comply with all laws, ordinances, rules, regulations and orders of any public authority bearing on the performance of the Work.

5.7.3 Unless otherwise provided in the Contract Documents, it is the responsibility of the Contractor to make certain that the Contract Documents are in accordance with the applicable laws, statutes, building codes and regulations. If the Contractor observes that any of the Contract Documents are at variance therewith in any respect, he shall promptly notify the Designated Representative in writing and any necessary changes shall be by appropriate Modification.

5.7.4 If the Contractor performs any Work knowing it to be contrary to such laws, ordinances, rules and regulations and without such notices to the Designated Representative he shall assume full responsibility therefore and shall bear all costs attributable thereto.

5.8 ALLOWANCES

5.8.1 The Contractor shall include in the Contract Sum as defined in Subparagraph 10.1.1, all allowances stated in the Contract Documents. Items covered by these allowances shall be supplied for such amounts and by such persons as the Designated Representative may direct, but the Contractor will not be required to employ persons against whom he makes a reasonable objection.

5.8.2 Unless otherwise provided in the Contract Documents, all allowances shall cover the cost to the Contractor, less applicable trade discount, of the materials and equipment required by the allowances delivered at the site and all applicable taxes.

5.8.3 Unless otherwise provided in the Contract Documents, the Contractor's costs for unloading and handling (including hoisting) on the site, labor, installation costs, overhead, profit and other expenses contemplated for the original allowance shall be included in the Contract Sum and not in the allowance.

5.8.4 Unless otherwise provided in the Contract Documents, whenever the cost is more than or less than the allowance, the Contract Sum shall be adjusted accordingly by Change Order, the amount of which recognizes changes, if any, in handling costs on the site, labor, installation costs, overhead, profit and other expenses.

5.9 SUPERINTENDENT

5.9.1 The Contractor shall employ an experienced, competent superintendent and necessary assistants who shall attend the Project site full time during the progress of the Work until the date of Substantial Completion and

for such additional time thereafter as the Designated Representative may deem necessary for the expeditious completion of the Work. The superintendent shall be satisfactory to the Designated Representative and shall not be changed without the consent of the Designated Representative, unless the superintendent proves to be unsatisfactory to the Contractor or ceases to be in its employ. The superintendent shall represent the Contractor and all communications given to the superintendent shall be as binding as if given to the Contractor. Important communications shall be confirmed in writing. Other communications shall be so confirmed on written request in each case.

5.9.2 The Contractor shall submit a job organization chart and resumes which identify the key personnel he intends to assign to the project, to the Designated Representative within 48 hours after receipt of the Notice to Proceed. The Owner, acting through the Designated Representative, reserves the right to approve the Contractor's proposed personnel and anyone not so approved shall be immediately replaced by someone acceptable. If in the course of construction, the Owner, on advice of the Designated Representative, determines that it would be in its best interest to request a change in the Contractor's personnel, he may do so; and the Contractor shall immediately assign a suitable replacement who is acceptable to the Owner and the Designated Representative at no additional cost.

5.9.2.1 A duly authorized representative of the Contractor shall be available for emergency telephone communication from the Owner or Designated Representative on a 24-hour basis, seven days a week during the performance of the Work.

5.10 CONSTRUCTION SCHEDULE

5.10.1 Submission of Schedule and Format

5.10.1.1 Within Five (5) calendar days of the Notice to Proceed, the Contractor shall submit to the Designated Representative a construction Schedule covering the entire project.

5.10.1.2 The Schedule shall be prepared utilizing the critical path method of scheduling. The Schedule will show the Contractor's plan for construction in sufficient detail to indicate the sequence of construction and planned dates for achieving major milestones.

5.10.1.3 The maximum duration for any single activity will be twenty (20) working days, with the exception of "Fabrication and Delivery" activities. Although portions of the Work may take longer than 20 working days, all work shall be presented in the schedule to allow for monitoring of progress through completion of incremental activities with a duration not exceeding 5 days.

5.10.1.4 A sufficient number of activities will be carried in the schedule so that each subcontract subdivision is represented and the planned start and completion of each Subcontractor's Work can be determined.

5.10.1.5 All submittals required by the specifications will be scheduled along with the approval period (fifteen calendar days minimum) and fabrication and delivery periods.

5.10.1.6 The Contractor shall submit to the Designated Representative for approval a computer-generated critical path schedule and bar charts. The schedule shall contain the following information and shall be presented in a legible format acceptable to the Designated Representative.

(a.) The critical path schedule shall indicate for each activity:

- Description
- Original Duration
- Remaining Duration
- Percentage Complete
- Total Float (critical path highlighted) Responsibility
- Code (who will perform the work) Early Start/Finish
- Dates (current update)
- Late Start/Finish Dates (current update)
- Predecessor and Successor Activities to the activity (arrow connections)

(b.) The Contractor shall submit a bar chart schedule listing all activities in the schedule as organized by responsibility, area or date as approved by the Designated Representative. The bar chart shall include all the information listed in paragraph (a.) above for each activity except the listing of predecessor and successor activities.

5.10.1.7 If construction must commence during Schedule preparation and approval period, the Contractor shall prepare a **twenty (20) calendar day schedule** to cover the initial field construction and submittals. Activities on this Schedule should have maximum durations of five (5) days to allow for monitoring of progress through completion of the incremental activities.

5.10.1.8 A copy of the Schedule shall be submitted via email to the Designated Representative for review. At the time of submittal, The Contractor's lead on-site manager or superintendent will make a presentation to the Designated Representative on the planned construction sequence/schedule. Within **Fifteen (15) calendar days** of receipt, the Designated Representative will notify the Contractor, in writing, as to any objections to the Schedule submitted. If the Schedule is deemed objectionable, the Contractor will have **five (5) calendar days** from receipt to revise the

schedule and resubmit it as above. The Contractor's presentation will include, but not be limited to:

- (a.) Describing the sequence and phasing of work.
- (b.) Delineating any area subdivision used to plan the work sequence/schedule. (c.) Identifying the critical path.
- (d.) Identifying when the milestone events specified herein are planned to be achieved (earliest and latest times). (e.) Any plans for shift work, weekend work, or extended work weeks and non-work days (i.e. holidays observed). (f.) Any planned interruptions of building power, water, communications, or other utilities.
- (g.) Any assumptions used in planning and sequencing the work. (h.) Long lead fabrication items.
- (i.) Manpower projections for the project. (j.) Noise/dust control measures.
- (k.) Safety plan.
- (l.) Plans for moving materials into the building and removing refuse and debris.
- (m.) Any other planning information requested by the Owner or its Designated Representative prior to the presentation.

5.10.2 Updating of the Schedule

5.10.2.1 The Schedule documents will be updated monthly at a minimum to reflect progress through the "Data Date". All contract changes as they are agreed to shall be specifically incorporated into the appropriate Schedule update. The Data Date may be the last working day of the month or it may be the "closure" date of the requisition for payment, as the Contractor may choose and as approved by the Designated Representative. However, when one of the above Data Dates is selected, it will be used throughout the project. The update will be submitted within **seven (7) calendar days** following the Data Date.

5.10.2.1 The Contractor shall submit marked up copies of the approved critical path schedule and the bar chart indicating progress through the data date. If the Contractor has elected to submit a computer-generated schedule, monthly update reports and schedule plots shall be submitted as directed by the Designated Representative.

5.10.3 Revision of the Schedule

5.10.3.1 Every effort shall be made by all parties to Work in accordance with the accepted Project Schedule. The Schedule will be revised only if the actual status of Work cannot be brought into conformance with the existing Schedule. If the Schedule is revised, the revised Schedule will be submitted as if any initial Schedule.

5.10.4 Minor Changes of the Schedule

5.10.4.1 The Schedule is not considered to be "revised" if the Contractor must make minor changes, such as: (a.) Adding additional details to a sub-network to facilitate coordination of subcontract Work.
 (b.) Additions/deletions/modifications of Schedule activities to reflect Work added or deleted by change order.

5.10.5 Extensions of Contract Time

5.10.5.1 All claims for extensions to contract time shall be supported by a detailed comprehensive analysis of the accepted Schedule. This analysis shall provide sufficient supporting evidence to justify a time extension. No time claims will be considered without the supporting analysis. If a time extension is granted, it shall be included in the next update of the Schedule.

5.10.6 During Construction

5.10.6.1 Construction milestone event dates will be incorporated into the detailed Construction Schedule as "target dates". These dates will be clearly noted and fixed on the Schedule graphics and corresponding computer file. It is the intent that the Work will be undertaken so as to achieve each target date and thereby achieve overall project completion as specified in the Contract.

5.10.6.2 The milestone event target dates will not be revised unless delays beyond the control of the Contractor occur.

5.10.6.3 If, when the Schedule is updated, the planned dates for achieving any milestone(s) falls more than ten (10) working days behind the target date(s), and if this has occurred through no fault of the Owner, the Architect/Engineer or their consultants, the Contractor may be directed by the Owner or the Designated Representative, to take any and all actions required to bring the actual construction back into accordance with the target dates.

5.10.6.4 When the Contractor falls behind its schedule and is not entitled to any time extension other than extensions already reflected in the current approved schedule, he shall submit its plan for bringing the Work back up to schedule and shall implement the plan. If other measures will not be sufficient to make up the lag, the Contractor's plan and implementation thereof shall include, but not be limited to increasing the number of shifts and days of Work, additional Work, additional equipment, increasing manpower and expediting deliveries, all at the Contractor's sole expense.

5.10.6.5 If the Contractor works overtime, more than forty (40) hours per week, Saturdays, Sundays or holidays; whether by choice or by necessity, the Contractor shall be responsible for the reimbursement of the Owner for additional costs

incurred for the Owner's, Designated Representative's and Architect/Engineer's overtime services.

- 5.10.6.6 In the event the Contractor fails or refuses to implement such measures as will bring its Work back up to conformity with the approved schedule, its right to proceed with any or all portions of the Contract requirements may be canceled or suspended; but permitting the Contractor to proceed shall in no way operate as a waiver of any rights of the Owner or deprive the Owner of its rights under any provisions of this contract.
- 5.10.6.7 The Contractor shall include milestone activities in the Schedule as applicable to the Work. Milestone events shall at a minimum include the following as applicable:

- (a.) Demolition and Excavation complete (b.)
Start foundation concrete
- (c.) Complete footings and piers
- (d.) Complete all subgrade concrete construction (e.)
Each level's structural slab complete
- (f.) Roof level structural slab complete
- (g.) Penthouse Level structural slab complete (h.)
Begin structural steel
- (i.) Complete structural steel (j.)
Complete decks/structure (k.)
Permanent power available
- (l.) Temporary heating/cooling available (m.)
Begin roofing
- (n.) Complete roofing
- (o.) Begin exterior facades (p.)
Complete exterior facades (q.)
Begin exterior glazing
- (r.) Complete exterior glazing (s.)
Building dry-in
- (t.) Elevators operational
- (u.) Begin mechanical/electrical/plumbing rough-in (v.)
Begin building controls
- (w.) Complete building controls (x.)
System start-up
- (y.) Begin partition rough-in (z.)
Complete partition rough-in (aa)
Begin drywall
- (bb) Begin finishes and millwork (cc)
Complete finishes and millwork
- (dd) Begin site work and landscaping
- (eye) Complete grading
- (ff) Begin underground utilities (gg)
Complete underground utilities (he)
Complete site paving
- (ii) Complete landscaping
- (juju) Substantial completion
- (kk) Start installation of Owner furnished equipment (all)
Project complete/beneficial occupancy

5.10.7 Owner Directed Schedule

5.10.7.1 On projects involving extensive coordination between the Contractor and the Owner's ongoing operations, the Owner may issue with the Contract Documents an Owner Directed Schedule which shall be used by the Contractor in preparing its plan of operations. The Contractor shall not deviate from the Owner Directed Schedule without the written prior approval of the Owner or Designated Representative. As indicated in Paragraph 5.10.6, the Contractor may be directed by the Owner or Designated Representative to take any and all actions required to perform the actual construction in accordance with the Owner Directed Schedule and its "targetdates".

5.11 SUBMITTAL SCHEDULE

5.11.1 The Contractor shall prepare a schedule of required submittals not later than **fourteen (14) days** after the receipt of the Notice to Proceed. The schedule shall include a complete list of items requiring shop drawings, design mixes, material certification, product data, brochures, catalog cuts, etc., to be approved by the Architect/Engineer. The Contractor shall coordinate all submittals requiring approvals by code enforcement agencies and shall include these special approvals in the submittal schedule. The schedule is to be submitted on a form approved by the Designated Representative. The schedule shall be updated monthly or as required by the Designated Representative. All shop drawings and other submittals shall be accompanied by a transmittal letter and reference should be indicated to the item numbers of the above-mentioned schedule. The Contractor is to indicate the following in its submittal schedule.

(a.) Description of item

(b.) Specification division, page numbers, article and paragraph (c.)

Type of submittal (shop drawings, sample, product data)

(d.) Date that submittal shall be delivered to the Designated Representative's office. (e.)

Date that Contractor must have approval.

(f.) Date that material, equipment must be on site in order to maintain the Contractor's progress schedule.

5.11.2 The Contractor's submittal schedule shall allow reasonable time (15 calendar days minimum) for review by the Designated Representative and the Architect/Engineer, and revision or correction, resubmittal and approval, sufficiently in advance of the time that the item is scheduled for incorporation into the Work.

5.11.3 The Designated Representative and the Architect/Engineer shall review the Contractor's submittal schedule for completeness, fulfillment of Specification requirements and compatibility with the anticipated construction schedule. The sequence and duration of Contractor, Architect/Engineer, Designated Representative activities on the submittal schedule may be adjusted by the Designated Representative.

5.12 DRAWINGS AND SPECIFICATIONS AT THE SITE

5.12.1 The Contractor shall maintain at the site for the Designated Representative and the Architect/Engineer, two (2) copies of all drawings, specifications, addenda, change orders, responses to requests for information, proposals and other modifications, in good order and marked currently to record all changes made during the construction, including any changes in locations, size and arrangement of the various components of the Work or any other variations from the drawings or shop drawings. The Contractor shall mark each drawing as the Work shown thereon is completed in the field, revising any or adding lines, dimensions, elevations, depths, notes or any other information required to accurately record conditions. These drawings, marked to record all changes during the construction and approved shop drawings, product data, samples, addenda, change orders, responses to requests for information, proposals and other records of modifications shall be delivered to the Designated Representative, for the Owner, upon completion of the Work.

5.12.1.1 In addition to maintaining and delivering to the Designated Representative those record drawings required by Subparagraph 5.12.1, the Contractor shall also prepare and submit to the Designated Representative, upon completion of the Work, record reproducible drawings if the technical specifications so require.

5.13

USE OF SITE

- 5.13.1 The Contractor shall confine operations at the site to areas approved by the Designated Representative, permitted by law, ordinances, permits and the Contract Documents and shall not unreasonably encumber the site with any materials or equipment.
- 5.13.2 The Contractor shall not disturb existing monuments and markers at the site. Should monuments or markers or both be disturbed at any time by the Contractor, he shall bear the cost of a licensed surveyor engaged by the Owner for the purpose of relocating such monuments or markers.
- 5.13.3 The Contractor shall lay out its Work and shall be responsible for the accuracy of all lines, elevations and measurements, grading, utilities and other Work executed by him under its Contract. He must exercise proper precaution to verify figures shown on drawing before laying out Work and will be held responsible for any error resulting from its failure to exercise such precaution.
- 5.13.4 All discrepancies shall be brought to the attention of the Designated Representative in writing for review and direction before proceeding with the Work. Should the Contractor proceed without direction, he shall be responsible to make whatever changes are necessary and pay call costs incurred by that Contractor, the Designated Representative, the Owner or other Contractors.
- 5.13.5 Any enclosure including safety barricades, perimeter rails, opening covers and devices required to protect the Work, workmen, materials or equipment shall be provided by the Contractor.
- 5.13.6 Weather protection shall be supplied by the Contractor and shall include all enclosure, supplemental heating and furnishing all other features (insulation, etc.), or meeting conditions required by the Designated Representative or by the specifications relative to the Contractor's Work, to protect the Work and any materials stored on site.
- 5.13.7 Protection of finished Work until acceptance shall be furnished by the Contractor.

5.14

CUTTING AND PATCHING WORK

- 5.14.1 The Contractor shall be responsible for all cutting or patching that may be required to complete the Work or to make its several parts fit together properly. He shall provide protection of existing Work as required.
 - 5.14.2 The Contractor shall not damage or endanger any portion of the Work or the Work of any separate contractors by cutting, patching or otherwise altering any Work or by excavation. The Contractor shall not cut or otherwise alter the Work of any separate contractor except with the written consent of the Designated Representative and of such separate contractor. The Contractor shall not unreasonably withhold from any separate contractor its consent to cutting or otherwise altering the Work.
 - 5.14.3 The Contractor shall not cut, weld to or otherwise alter any structural member without the written consent of the Architect/Engineer obtained through the Designated Representative.
-

5.15

DAILY AND FINAL CLEAN UP

- 5.15.1 The Contractor shall be responsible for daily and final clean up and continuous removal of all rubbish and debris from the building and site.
- 5.15.1.1 The Contractor at all times shall keep the premises free from accumulation of waste materials or rubbish caused by its operations. At the completion of the Work he shall remove all its waste materials and rubbish from and about the Project, as well as all its tools, construction equipment, machinery and surplus materials.
- 5.15.2 The job site shall be maintained in a neat and orderly condition and kept free from accumulations of waste materials and rubbish during the entire construction period. Remove all crates, cartons and other flammable waste materials or trash from the Work areas at the end of each working day to appropriate waste hauling receptacles.
- 5.15.3 Elevator shafts, electrical closets, pipe and duct shafts, chases, furred spaces and similar spaces which are generally unfinished, shall be cleaned and left free from rubbish, loose plaster, mortar drippings, extraneous construction materials, dirt and dust before Substantial Completion inspection.
- 5.15.4 The Contractor shall be responsible for the cleaning of all surfaces as necessary to make them free of spatters or other deposits of paint, plaster, mortar, concrete, adhesives, roofing, dirt, soil, oil, and all other materials foreign to the surface involved.

5.16

COMMUNICATIONS

- 5.16.1 The Contractor shall forward all communications to the Owner and Architect/Engineer through the Designated Representative.
- 5.16.1.1 The Contractor shall promptly return telephone calls or respond to any other form of communication initiated by the Designated Representative. Failure to promptly do so shall be considered lack of performance on the part of the Contractor.
- 5.16.1.2 All written correspondence to the Designated Representative shall be dated and signed by the Contractor or its authorized representative.
- 5.16.2 Weekly project progress review meetings will be conducted with Designated Representative, Architect/Engineer, their consultants as necessary, and Contractor in attendance. The Designated Representative may call for special meetings of the Contractor, Subcontractors and material suppliers as he deems necessary for the proper coordination of the Work. Such meetings shall be held at the job site on regular working days during regular working hours. Unless otherwise directed by the Designated Representative, attendance shall be mandatory for all parties notified to attend the meeting.

5.17

ROYALTIES AND PATENTS

- 5.17.1 The Contractor shall pay all royalties and license fees. He shall defend all suits or claims for infringement of any patent rights and shall save the Owner and Designated Representative harmless from loss on account thereof, except that the Owner shall be responsible for all such loss when a particular design, process or the product of a particular manufacturer or manufacturers is specified, but if the Contractor has reason to believe the design, process or product specified is an infringement of a patent, he shall be responsible for such loss unless he promptly gives such information to the Designated Representative.

5.18

INSURANCE

- 5.18.1 Indemnification
 - 5.18.1.1 CONTRACTOR shall defend, indemnify and save harmless the COUNTY, its officers, agents and employees from any and all claims, demands, damages, costs, expenses (including attorney's fees), judgments or liabilities arising out of this Agreement or occasioned by the performance or attempted performance of the provisions hereof; including, but not limited to, any act or omission to act on the part of the CONTRACTOR or its agents or employees or other independent contractors directly responsible to him; except those claims, demands, damages, costs, expenses (including attorney's fees), judgments or liabilities resulting from the sole negligence or willful misconduct of the COUNTY.
 - 5.18.1.2 CONTRACTOR shall notify the COUNTY immediately in the event of any accident or injury arising out of or in connection with this Agreement.
- 5.18.2 Insurance Requirements for Contractor
 - 5.18.2.1 Without limiting the CONTRACTOR's indemnification of the COUNTY, CONTRACTOR shall procure the following required insurance coverages at its sole cost and expense. All insurance coverages are to be placed with insurers which (1) have a Best's rating of no less than A: VII, and (2) are admitted insurance companies in the State of California. All other insurers require the prior approval of the COUNTY. Such insurance coverage shall be maintained during the term of this Agreement. Failure to comply with the insurance requirements shall place

CONTRACTOR in default. Upon request by the COUNTY, CONTRACTOR shall provide a certified copy of any insurance policy to the COUNTY within ten (10) working days.

5.18.2.2 Workers' Compensation Insurance: Statutory Workers' Compensation and Employers Liability Insurance shall cover all CONTRACTOR's staff while performing any work incidental to the performance of this Agreement. The policy shall provide that no cancellation, or expiration or reduction of coverage shall be effective or occur until at least thirty (30) days after receipt of such notice by the COUNTY. In the event CONTRACTOR is self-insured, it shall furnish a copy of Certificate of Consent to Self-Insure issued by the Department of Industrial Relations for the State of California. This provision does not apply if CONTRACTOR has no employees as defined in Labor Code Section 3350 et seq. during the entire period of this Agreement and CONTRACTOR submits a written statement to the COUNTY stating that fact.

5.18.2.3 General and Automobile Liability Insurance: The general liability insurance shall include bodily injury, property damage and personal injury liability coverage, shall afford coverage for all premises, operations, products and completed operations of CONTRACTOR and shall include contractual liability coverage sufficiently broad so as to include the insurable liability assumed by the CONTRACTOR in the indemnity and hold harmless provisions [above] of the Indemnification Section of this Agreement between COUNTY and CONTRACTOR. The automobile liability insurance shall cover all owned, non-owned and hired motor vehicles that are operated on behalf of CONTRACTOR pursuant to CONTRACTOR's activities hereunder. CONTRACTORS shall require all subcontractors to be included under its policies or furnish separate certificates and endorsements to meet the standards of these provisions by each subcontractor. COUNTY, its officers, agents, and employees shall be Additional Insured status on any policy. A cross liability clause, or equivalent wording, stating that coverage will apply separately to each named or additional insured as if separate policies had been issued to each shall be included in the policies. A copy of the endorsement evidencing that the policy has been changed to reflect the Additional Insured status must be attached to the certificate of insurance. The limit of liability of said policy or policies for general and automobile liability insurance shall not be less than \$1,000,000 per occurrence and \$2,000,000 in the aggregate. Any deductible or Self-Insured Retention {SIR} over \$10,000 requires approval by the COUNTY.

Said policy or policies shall include a severability of interest or cross liability clause or equivalent wording. Said policy or policies shall contain a provision of the following form: "Such insurance as is afforded by this policy shall be primary and non-contributory to the full limits stated in the declarations, and if the COUNTY has other valid and collectible insurance for a loss covered by this policy, that other insurance shall be excess only."

If the policy providing liability coverage is on a 'claims-made' form, the CONTRACTOR is required to maintain such coverage for a minimum of three years following completion of the performance or attempted performance of the provisions of this agreement. Said policy or policies shall provide that the COUNTY shall be given thirty (30) days written notice prior to cancellation or expiration of the policy or reduction in coverage.

5.18.2.4 CONTRACTOR shall submit to the office of the designated COUNTY representative certificate(s) of insurance documenting the required insurance as specified above prior to this Agreement becoming effective. COUNTY shall maintain current certificate(s) of insurance at all times in the office of the designated County representative as a condition precedent to any payment under this Agreement. Approval of insurance by COUNTY or acceptance of the certificate of insurance by COUNTY shall not relieve or decrease the extent to which the CONTRACTOR may be held responsible for payment of damages resulting from CONTRACTOR'S services of operation pursuant to the contract, nor shall it be deemed a waiver of COUNTY'S rights to insurance coverage hereunder. In the event the CONTRACTOR is not able to comply with the COUNTY'S insurance requirements, COUNTY may, at their sole discretion and at the CONTRACTOR'S expense, provide compliant coverage.

5.18.2.5 The above insurance requirements are subject to periodic review by the COUNTY. The COUNTY's Risk Manager is authorized to change the above insurance requirements, with the concurrence of County Counsel, to include additional types of insurance coverage or higher coverage limits, provided that such change is reasonably based on changed risk of loss or in light of past claims against the COUNTY or inflation. This option may be exercised during any **amendment** of this Agreement **that results in an increase in the nature of COUNTY's risk** and such change of provisions will be in effect for the term of the **amended** Agreement. Such change pertaining to types of insurance coverage or higher coverage limits must be made by **written** amendment to this Agreement. CONTRACTOR agrees to execute any such amendment within thirty (30) days of acceptance of the amendment or modification.

5.19 CONTRACTOR QUALITY CONTROL SYSTEM

5.19.1 The Contractor shall provide and maintain an effective quality control program of Contractor inspection system, which will assure that all supplies and services required under the Contract conform to the Contract Documents whether constructed or processed by the Contractor or procured from subcontractors or vendors. The Contractor shall substantiate that all supplies and services conform to the Contract Documents and shall also perform or have performed all inspections and tests otherwise required by the Contract Documents unless the required inspection and test is specifically designated to be performed by the Owner or the Owner's designated representative. Mechanical and electrical personnel, either engineers or highly qualified technicians shall be provided during the testing, balancing, adjusting and regulating mechanical and electrical devices and systems. The Contractor's inspection system shall be documented, as specified herein, and shall be available for review by the Designated Representative prior to the start of construction and throughout the life of the Contract. The Contractor shall notify the Designated Representative in writing of any proposed change to its inspection system and change shall be subject to disapproval if they would, in the opinion of the Designated Representative, result in non-conformance

with the Contract requirements. The Contractor's inspection system shall include the minimum requirements stated below. The Contractor's full-time job site superintendent may function as the Contractor's Contractor Quality Control representative.

- 5.19.1.1 Preparatory Inspection: The Contractor's Quality Control organization shall perform prior to the beginning any Work on any definable segment of Work; a review of contract requirements; a check to assure that all materials and equipment have been tested, submitted and approved; a check to assure that provisions have been made to provide required control testing; examination of the Work area to ascertain that all preliminary Work has been completed; and a physical examination of materials and equipment to assure that they conform to approved shop drawings or submittal data and that all material and equipment are on hand. As a part of this preparatory Work, the Contractor's Quality Control organization will review and certify all shop drawings, certificates and other submittal data prior to submission to the Designated Representative. Each submittal offered to the Designated Representative will bear the date and the signature of a member of the Contractor's Quality Control organization indicating that he has reviewed the submittal and certified it to be following the Contract Documents (or showing the required change). The Designated Representative shall be notified a minimum of seventy-two (72) hours prior to the beginning of a Preparatory Inspection.
- 5.19.1.2 Initial Inspection: The Contractor's Quality Control organization shall perform, as soon as a representative segment of the particular item of Work has been accomplished, an examination of the quality of workmanship and a review of control testing for compliance with Contract Requirements, use of defective or damaged materials, omissions, and dimensions requirements.
- 5.19.1.3 Follow-Up Inspection: The Contractor's Quality Control organization shall perform daily, or as frequently as necessary, follow up inspections to assure continuing compliance with Contract Requirements, including control testing, until completion of the particular segment of the Work.
- 5.19.1.4 The Contractor shall maintain current records on an appropriate approved format of all inspections and tests performed. These records should provide factual evidence that the required inspections or tests have been performed, including type and number of inspections or tests involved; results of inspections or tests; nature of defects, causes for rejection, etc.; proposed remedial action and corrective actions taken. The Contractor shall not build upon or conceal any feature of the Work containing uncorrected defects, and payment on deficient items will be withheld until satisfactorily corrected or other actions taken as authorized. These records must cover both conforming and defective items and shall include a statement that all supplies and materials, incorporated in the Work, are in full compliance with the terms of the contract. Legible copies shall be furnished to the Designated Representative. The report will cover all Work placement subsequent to the previous report and will be verified by the prime Contractor's Quality Control representative. The Contractor shall include in all subcontracts, purchase orders or other agreements, either written or oral, with a commercial testing laboratory for quality control testing under the subject Contract, a requirement that copies of any test reports, data or other information relating to tests conducted by said laboratory under this Contract, be mailed simultaneously to the Designated Representative when said report, data or other information are mailed or delivered to the Contractor.
- 5.19.1.5 The Contractor shall establish controls necessary to assure scheduled completion dates established by the Contract are not impacted by the delinquent submittal data and operational tests. **twenty (20)** days in advance of the Substantial Completion and prior to scheduling a pre-final inspection of the Work, or any phase of Work, under the Contract, the Contractor's Quality Control organization shall submit to the Designated Representative a complete and factual report of all remaining submittals, inspections and tests required prior to acceptance of the Work. The report shall include the following:
 - (a.) A list of outstanding shop drawing submittals or re-submittals requiring approval by the Contractor.
 - (b.) A list of manuals, test reports, spare parts, keys, etc., to be furnished to the Designated Representative and scheduled submittal dates.
 - (c.) Schedule of required operations tests and instruction periods.
 - (d.) Scheduled delivery dates for materials or equipment impacting contract completion dates.
 - (e.) Plan of action by the Contractor for correcting all known contract deficiencies including delay in scheduled progress.
- 5.19.1.6 The Contractor shall maintain marked-up documents depicting Record Document conditions. These drawings will be maintained in a current condition at all times until completion of the Work and will be available for review by the Designated Representative at all times. All variations from the Contract Documents, for whatever reason, including those occasioned by the required coordination between trades, will be indicated. These variations will be shown in the same general detail utilized in the Contract Documents. Upon Substantial Completion, the marked-up documents shall be furnished to the Designated Representative for delivery to the Owner or the Owner's designated representative. The Contractor shall also furnish Record Documents as provided in the Technical Provisions of the specifications.
- 5.19.1.7 After the Contract is awarded and before construction operations are started, the Contractor shall meet with the Designated Representative and discuss the inspection system requirements. The meeting shall develop mutual understanding relative to details of the Contractor's Quality Control system including the form to be used for

recording the inspection, administration of the system and the interrelationship of the Contractor and the Designated Representative. The Contractor shall furnish to the Designated Representative within five (5) days after receipt of the Notice to Proceed, an inspection system plan which shall include the procedures, instructions and reports to be used. No progress payments will be processed under this Contract until the inspection plan is acceptable to the Owner and the Designated Representative. The Contractor's Quality Control plan documentation will include the following minimum elements:

- (a.) The inspection organization.
- (b.) Number and qualifications of inspection personnel to be used. (c.) Authority and responsibilities of inspection personnel.
- (d.) Schedule of use of inspection personnel by types and phase of Work. (e.) Methods of inspection, including Subcontractor's work.
- (f.) Test methods including as specified, name of qualified testing laboratory to be used, if applicable. (g.) Method of documenting inspection and testing.
- (h.) A copy of a letter of direction to the Contractor's Quality Control representative responsible for the quality control inspection, outlining its duties and responsibilities and signed by a responsible officer of the firm.

- 5.19.1.8 The Contractor's Quality Control inspection system shall provide for procedures which will assure that the latest applicable drawings, including shop drawings, specifications and instruction required by the contract, as well as authorized changes thereto, are used for fabrication, inspection and testing.
- 5.19.1.9 The Designated Representative and the Architect/Engineer reserves the right to inspect at source supplies or services not manufactured or performed within the Contractor's facility. The Designated Representative's and the Architect/Engineer's inspection shall not constitute acceptance, nor shall it in any way replace Contractor inspection or otherwise relieve the Contractor of its responsibility to furnish an acceptable end item. When inspection at Subcontractor's plant is performed by the Designated Representative, such inspection shall not be used by Contractor as evidence of effective inspection by such Subcontractor.
- 5.19.1.10 The Designated Representative may notify the Contractor or its Quality Control representative at the site of noncompliance with the foregoing provisions. This notice may be in writing by a form titled "Deficiency Correction Report" or "Notice of Noncompliance". The Contractor shall immediately, upon receipt of said notice, indicate the corrective action which will be taken and the date by which it will be complete, and submit this data for the Designated Representative's approval. If the Contractor refuses to comply promptly with these requirements, the Designated Representative may issue an order stopping all or part of the Work until satisfactory corrective action has been taken. No part of the time lost or cost of damages due to such stop orders shall be compensable and payment representing the noncompliance item and corrective action will be withheld until the Designated Representative has approved the corrective action.
- 5.19.1.11 Each of the Contractor's Quality Control Inspectors shall be responsible for inspecting the Work under its surveillance for compliance with OSHA Standards for the Construction Industry Section and approved safety program and shall immediately bring to the attention of the Contractor's supervisory personnel any unsafe Work conditions and instance of noncompliance noted.
- 5.19.2 Certificates of Compliance: The Designated Representative may require certificates of compliance with the specifications for materials or manufactured items produced outside of the job site. Such certificates will not relieve the Contractor from the requirements of providing material and manufactured items complying with the specifications even though they have been incorporated into the job.
- 5.19.3 Weighing Equipment: All scales used for proportioning materials shall be inspected for accuracy and certified within the past twelve (12) months by the State of California Bureau of Weights and Measures, by the County Director or Sealer of Weights and Measures, or by a Scale Mechanic registered with or licensed by the County.
- 5.19.3.1 The accuracy of the work of a scale service agency, except as stated herein, shall meet the standards of the California Business and Professions Code and the California Administrative Code pertaining to weighing devices. A certificate of compliance shall be presented prior to operation to the Designated Representative for approval and shall be renewed whenever required by the Designated Representative at no cost to the Owner.
- 5.19.3.2 All scales shall be so arranged that they may be read easily from the operator's platform or area. They shall indicate the true net weight without the application of any factor. The figures of the scales shall be clearly legible. Scales shall be accurate to within 1% when tested with the plant shut down. Weight equipment shall be so insulated against vibration or moving of other operating equipment in the plant area that the error in weighing with the entire plant running will not exceed 2% for any setting nor 1-1/2% for any batch.

5.20 COMPLETION INSPECTIONS

- 5.20.1 Contractor's Quality Control Completion Inspection: Based upon the Designated Representative's concurrence that the Work is nearing Substantial Completion, at least 15 days prior to pre-final inspection, the Contractor's Quality Control Inspection personnel shall conduct a detailed inspection. The Designated Representative shall be notified of the inspection date in order that he may participate, if s/he so elects. The Work shall be inspected for conformance to plans, specifications, quality, workmanship and completeness. The Contractor shall prepare an itemized list of Work not properly completed, inferior workmanship or not conforming to Contract Documents. The list shall also include outstanding administrative items such as Record Documents, operations and maintenance

manuals, spare parts, installed property list, etc. The list shall be included in the Quality Control documentation and submitted to the Designated Representative with an estimated date for correction of each deficiency within five (5) working days after conducting this inspection.

- 5.20.2 Pre-Final Inspection: The Contractor's Quality Control Inspection personnel, its superintendent, or other primary management person and the Designated Representative will attend this inspection. Additional Owner personnel, including but not limited to those from the Owner's General Services Department user groups, Board of Supervisors and the Architect/Engineer may be in attendance. The pre-final inspection will be formally scheduled by the Owner or the Designated Representative based upon notice from the Contractor. This notice will be given to the Owner or the Designated Representative at least **ten (10)** days prior to the pre-final inspection and must include the Contractor's assurance that all specific items previously identified to the Contractor as being unacceptable, along with the remaining Contract Work will be complete and acceptable by the date scheduled for the pre-final inspection. Failure of the Contractor to have all Contract Work acceptably complete for this inspection will be the cause of the Owner or the Designated Representative to be reimbursed by the Contractor for the additional inspection costs of the Owner or the Designated Representative. At this inspection, the Owner or the Designated Representative will develop a specific list of incomplete and unacceptable Work performed under the Contract and will subsequently furnish this list to the Contractor. Failure of the Owner or the Designated Representative to detect or list all incomplete and unacceptable Work during this inspection will not relieve the Contractor from acceptably performing all Work required by the Contract Documents. The Owner or the Designated Representative, at their option, may accept this inspection as the final acceptance inspection, if in its opinion the completion status of the inspected facilities and other Work performed under the Contract warrant this consideration.
- 5.20.3 Final Acceptance Inspection: The Contractor's Quality Control Inspection personnel, its superintendent or other primary management persons and the Owner or the Designated Representative will attend this inspection. Additional Owner personnel including, but not limited to, those from the Owner's General Services Department, user groups, Board of Supervisors and the Architect/Engineer may also be in attendance. The final acceptance inspection will be formally scheduled by the Owner based upon the Contractor's written assertion to the Owner that the Work is complete. This notice will be given to the Owner or the Designated Representative at least **five (5) days** prior to the final acceptance inspection and must include the Contractor's assurance that all specific items previously identified to the Contractor as being unacceptable, along with all remaining Work performed under the Contract, will be complete and acceptable by the date scheduled for the final acceptance inspection. Failure of the Contractor to have all Work acceptably complete for this inspection will be cause for the Owner and the Designated Representative to bill the Contractor for any additional inspection costs.
- 5.20.4 If, in the Designated Representative's judgment, the work has been completed in accordance with the plans and specifications and is ready for acceptance he will so certify to the Owner, which may accept the completed work. The Designated Representative will, in its certification to the Owner, give the date when the work was completed. This will be the date when the Contractor is relieved from responsibility to protect the work. This will also be the date to which liquidated damages will be computed.

5.21 WARRANTY OF CONSTRUCTION

- 5.21.1 Performance Bond: The Performance Bond shall remain in effect for a 12-month warranty period after the date of substantial completion, as determined by the County. Extended warranty periods shall be provided under manufacturer warranties, as required by project specifications.
- 5.21.2 In the event that the Contractor or its designated representative fails to commence and diligently pursue all Work required under Paragraph 5.5 within a reasonable time after receipt of written notification pursuant to the requirements thereof, the Owner or the Designated Representative shall have the right to demand that said Work be performed under the Performance Bond by making written notice on the surety. If the surety fails or refuses to perform the obligation it assumed under the Performance Bond, the Owner or the Designated Representative shall have the Work performed by others, and after completion of the Work, shall make demand for reimbursement of any or all expenses incurred by the Owner while performing the Work, including, but not limited to, administrative personnel.
- 5.21.3 Warranty repair work which arises to threaten the health or safety of personnel or the safety of property or equipment will be handled by the Contractor on an immediate basis as directed verbally by the Owner or the Designated Representative. Written verification will follow the Owner's or the Designated Representative's verbal instructions. Failure of the Contractor to respond as verbally directed will be cause for the Owner or the Designated Representative to have the warranty repair work performed by others and to proceed against the Contractor as outlined in Paragraph 5.21.2 above.
- 5.21.4 Pre-Warranty Conference: Prior to Substantial Completion and at a time designated by the Owner or the Designated Representative, the Contractor shall meet with the Owner or the Designated Representative to develop a mutual understanding with respect to the requirements of Paragraph 5.5 of this specification. The Owner or the Designated Representative shall establish communication procedures for the Contractor notification of warranty defects, priorities with respect to the type of defect and reasonable time required for the Contractor response and other details deemed necessary by the Owner or the Designated Representative for the execution of the construction warranty. In connection with these requirements, the Contractor will furnish the name, telephone number and address of a licensed and bonded company which is authorized to initiate and maintain warranty Work action on behalf of the Contractor. This single point of contact will be located within the local service area of the warranted construction and will be responsive to the Owner's inquiry on warranty Work action and status. This

requirement does not relieve the Contractor of any of its responsibilities in connection with Paragraph 5.5.

5.22

SUBCONTRACTS

- 5.22.1 Each bidder shall file with its bid the name, license number, and the location of the place of business of each subcontractor who will perform work or labor or render service to the Contractor in or about the construction of the work or improvement, or a subcontractor licensed by the State of California who, under subcontract to the Contractor, specially fabricates and installs a portion of the work or improvement according to detailed drawings contained in the plans and specifications, in an amount in excess of one-half of one percent of the Contractor's total bid. Each bidder shall state the portion of the work which will be done by each subcontractor under this act. The Contractor shall list only one subcontractor for each such portion as is defined by the Contractor in its bid.
- 5.22.2 In each instance, the nature and extent of the work to be sublet shall be described. The failure of the Contractor to specify a subcontractor, or the listing of more than one subcontractor for the same portion of the work, constitutes an agreement by the Contractor that he is fully qualified to perform that portion himself, and that he shall perform that portion himself.
- 5.22.3 The Contractor must have the written consent of the Owner to substitute a subcontractor other than that designated in the original bid, to permit any subcontract to be assigned or transferred, or to allow a subcontract to be performed by other than the original subcontractor. The Contractor shall submit an acknowledgement signed by the original subcontractor that there is no objection to its replacement by another subcontractor. Any substitution of subcontractors must comply with California Public ContractCode.
- 5.22.4 Subcontracting of work for which no subcontractor was designated in the original bid, and which is more than one-half of one percent of the work, will be allowed only in cases of public emergency or necessity, and then only after a finding reduced to writing as a public record of the Owner, setting forth the facts constituting the emergency or necessity.
- 5.22.5 Violation of any of the above provisions will be considered a violation of the Contract, and the Owner may cancel the Contract or assess the Contractor a penalty of not more than 10% of the subcontract involved.
- 5.22.6 All persons engaged in the work, including subcontractors and their employees, will be considered as employees of the Contractor. He will be held responsible for their work. The Owner will deal directly with, and make all payments to the Contractor.
- 5.22.7 When subcontracted work is not being prosecuted in a satisfactory manner, the Contractor will be notified to take corrective action. If the Owner so orders, and on receipt by the Contractor of written instructions from the Owner, the subcontractor shall be removed immediately from the work. He shall not again be employed on the work.

5.23

LAWS TO BE OBSERVED

- 5.23.1 The Contractor shall keep himself fully informed of State and National laws and County and municipal ordinances and regulations which in any manner affect those employed in the work or the materials used in the work or in any way affect the conduct of the work. He shall at all times observe and comply with all such laws, ordinances and regulations.
- 5.23.2 Santa Barbara County Ordinance 2946 Unlawful Discrimination in Employment Practices: Contractor agrees with the County of Santa Barbara that it will not discriminate against any employee or applicant for employment in violation of any applicable State or Federal laws, rules or regulations which may now or hereafter specifically prohibit such discrimination on such grounds as race, religion, sex, color, national origin, physical handicap when otherwise qualified, Vietnam era veteran/disabled or age. If it is determined by the Board of Supervisors upon recommendation of the Affirmative Action Officer and the County Counsel that during the life of this contract any such unlawful discriminations have occurred, the County Board of Supervisors may forthwith terminate this contract. Contractor further agrees that whether or not the term of this contract is still in existence at the time of final determination of such unlawful discrimination, that it will forthwith reimburse the County for any and all damages, costs and expenses incurred in connection with such unlawful discrimination, including but not limited to damages from loss of Federal or State grants, subventions or loans; costs of processing, investigating and reporting complaints of unlawful discrimination; additional costs or expenses incurred in completion of this agreement by another party if this agreement is terminated before completion; all costs of suit including reasonable attorney's fees incurred in collecting any such damages, costs and expenses; and interest at 7% on all such damages, costs and expenses from the date they are incurred to date of payment.
 - 5.23.2.1 Employment practices shall include, but are not limited to employment, promotion, demotion, transfer, recruitment and advertising for recruitment, layoff or other termination, rates of pay, employee benefits and all other forms of compensation, selection for training and apprenticeship and probationary periods.
 - 5.23.2.2 Contractor further agrees to permit access at all reasonable times and places to all of its records of employment advertising, application forms, tests and all other pertinent employment data and records, to the County of Santa Barbara, its officers, employees and agents for the purpose of investigation to ascertain if any unlawful discrimination as described herein has occurred or is being practiced.
 - 5.23.2.3 Failure to fully comply with any of the foregoing provisions relating to unlawful discrimination in employment

practices shall be deemed to be a material breach of this contract.

ARTICLE 6: SUBCONTRACTORS

6.1 DEFINITION

- 6.1.1 A Subcontractor is a person or entity who has a direct contract with a Contractor to perform any of the Work at the site. The term Subcontractor is referred to throughout the Contract Documents as if singular in number and masculine in gender and means a Subcontractor or its authorized representative.
- 6.1.2 Nothing in the Contract Documents shall create any contractual relationship between the Owner, the Architect/Engineer or the Designated Representative and any Contractor, any Subcontractor, or any Sub-subcontractor or its authorized representative.

6.2 SUB-CONTRACTUAL RELATIONS

- 6.2.1 By an appropriate agreement, written where legally required for validity, the Contractor shall require each Subcontractor to the extent of the Work to be performed by the Subcontractor, to be bound to the Contractor, by the terms of the Contract Documents and to assume toward the Contractor all the obligations and responsibilities which the Contractor, by these documents, assumes toward the Owner, the Designated Representative or the Architect/Engineer. Said agreement shall preserve and protect the rights of the Owner, the Designated Representative and the Architect/Engineer under the Contract Documents with respect to the Work to be performed by the Subcontractor so that the subcontracting thereof will not prejudice such rights and shall allow to the Subcontractor, unless specifically provided otherwise in the Contractor-Subcontractor agreement, the benefit of all rights, remedies and redress against the Contractor that the Contractor, by these Documents has against the Owner or Designated Representative. Where appropriate, the Contractor shall require each Subcontractor to enter into similar agreements with its Sub-subcontractors. The Contractor shall make available to each proposed Subcontractor, prior to the execution of the Subcontract, copies of the Contract Documents to which the Subcontractor will be bound by this Paragraph 6.3 and shall identify to the Subcontractor any terms and conditions of the proposed Subcontract which may be at variance with the Contract Documents. Each Subcontractor shall similarly make copies of such Documents to its Subcontractors.

ARTICLE 7: SEPARATE CONTRACTS

7.1 OTHER CONTRACTORS

- 7.1.1 The Owner reserves the right to let other separate contracts in connection with the Work of the Project. The Contractor shall cooperate with other separate contractors and he shall afford the Designated Representative and other Contractors reasonable opportunity for the introduction and storage of their materials and equipment and execution of their Work and shall properly connect and coordinate its Work with others under the general direction of the Designated Representative. Temporary structures, equipment or materials shall be located where directed by the Designated Representative and if not so located, they shall be moved by the Contractor when directed at no additional cost.

7.2 CONTRACTOR TO INSPECT OTHER WORK

- 7.2.1 If any part of the Contractor's Work depends, for proper execution or results, upon the Work of the Designated Representative or any separate contractor, the Contractor shall, prior to proceeding with the Work, inspect and measure Work already in place and promptly report to the Designated Representative any discrepancies from the drawings and specifications or defects in such Work that render it unsuitable for such proper execution and results. The Contractor shall submit the report of discrepancies or defects in the form of a written request for information. Failure of the Contractor to so report shall constitute an acceptance of the other contractor's Work as fit and proper to receive its Work, except as to defect which may develop after the execution of its Work.
- 7.2.2 Copies of Drawings and specifications relating to these separate contracts will be available to the Contractor, upon request, for its information in carrying out the above provisions. The Contractor shall be held responsible for any damage or misfit resulting from its neglect to comply with the foregoing.

7.3 COORDINATION AND COOPERATION

- 7.3.1 The Contractor shall coordinate Work to be done hereunder with the Work of such other contractors in such manner as the Designated Representative may direct. The Work shall be scheduled and executed at such time and in such a way as to cause the least inconvenience to the Owner and with proper consideration for the rights of other contractors and public. The Contractor shall keep fully informed with the entire operation and install its Work promptly.
- 7.3.2 If the Designated Representative determines that the Contractor is failing to coordinate its Work with the Work of other contractors as directed, he may, upon written notice to the Contractor recommend the following actions by the Owner:
- 7.3.2.1 The Owner may withhold any payment otherwise due hereunder until the Designated Representative's directions are complied with by the Contractor.

- 7.3.2.2 The Owner, through the Designated Representative, may direct other contractors to perform portions of the contract and charge the cost of such Work to the contract amount.
- 7.3.2.3 The Owner may terminate any and all portions of the contract for the Contractor's failure to perform in accordance with the contract.
- 7.3.3 If the Contractor notifies the Designated Representative, in writing, that another contractor on this project is failing to coordinate its Work with the Work of this contract, as directed, the Designated Representative will promptly investigate the charge. If he finds it to be true, he will promptly issue such directions to the other contractor with respect thereto as the situation may require. The Designated Representative shall not, however, be liable for any damages suffered by this contractor by reason of the other contractor's failure to promptly comply with the directions so issued by the Designated Representative or by reason of another contractor's default in performance; it being understood that the Designated Representative does not guarantee the responsibility or continued efficiency of any contractor.
- 7.3.4 In the event of any labor dispute, affecting the Contractor or its employees, the Contractor shall utilize all possible means to resolve the dispute in order that the project not be delayed to any extent.
- 7.3.5 The Contractor shall cooperate with the Owner, the Architect/Engineer and the Designated Representative and other Contractors working on this project in order to avoid interference, inconvenience or damage. To aid in avoiding conflicts, the Contractor, without additional charge, shall make all reasonable modification in the Work as may be directed by the Designated Representative. In the event of the Contractor's operations causes any damage, interference, or inconvenience to Work being carried out under any other contract, the Contractor shall restore, replace, rectify, or otherwise make good any damage to the satisfaction of the Designated Representative or to the other contractors. Should the responsible Contractor fail to comply with this provision, the Work will be done by others at the expense of the responsible Contractor.
- 7.3.6 The Contractor shall ensure that all labor employed by him, its agents, or those he assigns for Work on the project shall be in harmony with and be compatible with all other labor being used by the Designated Representative or other Contractors. The Contractor shall observe hours and conditions of labor as directed by Designated Representative and in any event, in compliance with all applicable laws, ordinances and regulations. The Contractor shall coordinate its work with the work of other Contractors, the Owner and the Designated Representative and shall provide adequate information and planning of its work to allow for effective coordination by others with its operations. Whenever the Contractor has knowledge that any actual or potential labor dispute is delaying or threatens to delay the timely performance of the Work of this contract, the Contractor shall immediately give notice thereof to the Designated Representative. The Contractor shall then confirm the notice, in writing within 24 hours of the giving thereof, and shall include all relevant information with respect thereto. No claims will be accepted for costs incurred as a result of jurisdictional or labor practice disputes.

7.4 OWNER'S RIGHT TO CLEAN UP

- 7.4.1 If a dispute arises between the separate contractors as to their responsibility for cleaning up as required by Paragraph 5.15, the Owner may clean up and charge the cost thereof to the Contractor responsible therefore as the Owner shall determine to be just.

7.5 DAMAGES TO WORK

- 7.5.1 Should the Contractor wrongfully cause damage to the Work or property of the Owner or to other Work on the site, the Contractor shall promptly remedy such damage.
- 7.5.2 Should the Contractor wrongfully cause damage to the Work or property of any other Contractor, the Contractor shall, upon due notice, promptly attempt to settle with the other Contractor by agreement, or otherwise resolve the dispute. If such other Contractor sues the Owner or the Designated Representative or initiates any legal proceeding against the Owner or the Designated Representative on account of any damage alleged to have been caused by the Contractor, the Owner or Designated Representative shall notify the Contractor who shall defend such proceedings at the Contractor's expense and if any judgment or award against the Owner or Designated Representative arises from, the Contractor shall pay or satisfy it and shall reimburse the Owner or Designated Representative for all attorney's fees and court costs which the Owner or Designated Representative has incurred.
- 7.5.3 Should the Contractor sustain any damage through any act or omission of any other contractor having a contract for the performance of Work upon the site or of Work which may be necessary to be performed for the proper execution of the Work to be performed hereunder, the Contractor shall have no claim against the Owner, Architect/Engineer, Designated Representative or the Owner's consultants for such damage, but shall have a right to recover such damage from the other contractor as provided herein.
- 7.5.4 The Contractor shall indemnify and hold the Owner, Architect/Engineer and Designated Representative harmless from any and all claims or judgments for damages and from costs and expenses to which the Owner and Designated Representative may be subjected or which either may suffer or incur by reason of the Contractor's failure to comply with the Designated Representative's directions promptly.

ARTICLE 8: MISCELLANEOUS PROVISIONS

8.1 GOVERNING LAW

8.1.1 This contract shall be governed by the laws of the State of California.

8.2 SUCCESSORS AND ASSIGNS

8.2.1 The Owner and the Contractor each binds himself, its partners, successors, assignees and legal representatives to the other part hereto and to the partners, successors, assignees and legal representatives of such other parties in respect to all covenants, agreements and obligations contained in the Contract Documents. Neither party to the Contract shall assign the Contract nor sublet it as a whole without written consent of the other.

8.2.1.1 The Contractor shall not assign any monies due, or to become due, under this Contract without prior written consent of the Owner obtained through the Designated Representative.

8.3 WRITTEN NOTICE

8.3.1 Written notice shall be deemed to have been duly served if delivered in person to the individual or member of the firm or entity or to an officer of the corporation for whom it was intended, or if delivered at or sent by the registered or certified mail to the last business address known to him who gives the notice.

8.4 CLAIMS FOR DAMAGES

8.4.1 Should either party to the Contract suffer injury or damage to person or property because of any act or omission of the other party or of any of its employees, agents or others for whose acts he is legally liable, claims shall be made in writing to such other party within a reasonable time after the first observance of such injury or damage.

8.5 PERFORMANCE BOND AND LABOR MATERIAL PAYMENT BOND

8.5.1 The Contractor shall deliver to the Designated Representative, on forms approved by the Designated Representative and Owner, all executed and Standard Performance Bond and Standard Labor Material Payment Bond and a one (1) year Maintenance (Warranty) Bond, both with an approved surety acceptable to the Owner or Designated Representative and each payable in the amount at least equal to one hundred (100%) percent of the accepted bid as guarantee for the faithful performance of the Contractor and the payment of all persons who have, and fulfill, contracts which are directly with the successful bidder. The sureties of all bonds shall be of such security company or companies as are approved by the Designated Representative and the Owner. No Contract shall be deemed to be in effect until all bonds have been approved.

8.5.2 The insurance and bonding companies providing or underwriting such bonding shall be duly authorized and registered to do business in the State of California and shall be acceptable to the Owner and the Designated Representative.

8.5.3 The performance bond required by the Contract Documents shall remain in full force and effect during the warranty periods required by the Contract so as to give the Designated Representative and Owner recourse on the bond if the Contractor fails to remedy defects during the warranty period.

8.5.4 The Contractor's Payment and Performance Bond shall name the Owner as obligee.

8.6 RIGHTS AND REMEDIES

8.6.1 The duties and obligations imposed by the Contract Documents and the rights and remedies available there under shall be in addition to and not a limitation of any duties, obligations, rights and remedies otherwise imposed or available by law.

8.6.2 No action or failure to act by the Designated Representative, Architect/Engineer or Contractor shall constitute a waiver of any right or duty afforded any of them under the Contract Documents nor shall any such action or failure to act constitute an approval or acquiescence in any breach there under, except as may be specifically agreed in writing.

8.7 TESTS

8.7.1 If the Contract Documents, laws, ordinances, rules, regulations or orders of any public authority having jurisdiction require any portion of the Work to be inspected, tested or approved, the Contractor shall give the Designated Representative timely notice of its readiness so the Architect/Engineer and Designated Representative may observe such inspection, testing, or approval. The Owner shall bear all costs of such inspections, tests or approvals unless otherwise provided. The Contractor shall bear all costs of retesting any work failing to pass initial testing.

8.7.2 If the Architect/Engineer or Designated Representative determine that any Work requires special inspection, testing, or approval which Subparagraph 8.7.1 does not include, he will, through the Designated Representative, instruct the Contractor to prepare for such special inspection, testing or approval and the Contractor shall give notice as in Subparagraph 8.7.1. If such special inspection or testing reveals a failure of the Work to comply with the requirements of the Contract Documents, Contractor shall bear all costs thereof, including compensation for the

Architect/Engineer's and the Designated Representative's additional services made necessary by such failure. If the Work complies, the Owner shall bear such costs and an appropriate Change Order shall be issued.

- 8.7.3 Where operating tests are specified, the Contractor shall test its Work as it progresses, on its own account and shall make satisfactory preliminary tests in all cases before applying to the Designated Representative for official tests.
- 8.7.4 Official tests shall be made as directed by the Designated Representative, in the manner specified, for the different branches of the Work or portions thereof. The Contractor shall furnish all materials and apparatus, make connections and conduct the official test under the observation of the Owner's independent testing agency where appropriate. The official test will be conducted in the presence of a representative of the Designated Representative. Should defects appear, they shall be corrected by the Contractor and the official test repeated until the installation is acceptable to the Designated Representative.
- 8.7.5 Required certificates of inspection, testing or approval shall be secured by the Contractor and promptly delivered by him through the Designated Representative to the Architect/Engineer.
- 8.7.6 If the Architect/Engineer or Designated Representative is to observe the inspections, tests or approval required by the Contract Documents, he will do so promptly and, where practicable, at the source of supply.
- 8.7.7 The Contractor shall deliver test samples of any of the materials specified in any of the Sections of the Specifications to the Owner's testing agency. This may apply to materials proposed for use, materials already delivered to the job, or materials already incorporated into the construction.
- 8.7.8 Neither the observations of the Architect/Engineer or the Designated Representative in their Administration of the Construction Contract, nor inspections, tests or approvals by persons other than the Contractor shall relieve the Contractor from its obligation to perform the Work in accordance with the Contract Documents.
- 8.7.9 Any materials which fail to meet the requirements of these specifications shall not be used whether or not previously approved by the Architect/Engineer. If they have been delivered to the job, they shall be removed. If they have already been incorporated into the construction, the Designated Representative or Architect/Engineer may order them removed, or, at the discretion of the Owner through the Designated Representative, they may be permitted to remain in place, providing the Contractor agrees to a proper deduction from the contract sum.
- 8.7.10 The services of a testing and inspection engineer, selected by the Owner, Designated Representative and Architect/Engineer, shall be provided and paid for by the Owner for the tests required in the various sections, unless specifically stated otherwise or due to deficient Work.
- 8.7.11 No Work of any kind shall be covered or enclosed before it has been tested and approved.

8.8 ORDER OF PRECEDENCE

- 8.8.1 In the event of any conflict or discrepancy in the provisions of the Contract Documents, the documents shall be interpreted on the basis of the following order or priority:
- (a.) Agreement between the Owner and the Contractor Addenda,
 - (b.) with later date having greater priority Special Conditions
 - (c.) General Requirements and Other Conditions Drawings
 - (d.) and Specifications
 - (e.)
- 8.8.2 In the case of an inconsistency between Drawings and Specifications or within either Document not clarified by addendum the better quality or greater quantity of Work shall be provided in accordance with the Architect/Engineer's and Designated Representative's interpretation.

ARTICLE 9: TIME

9.1 DEFINITIONS

- 9.1.1 Unless otherwise provided, the Contract Time is the period of time allotted in the Contract Documents for the Substantial Completion of the Work as defined in Subparagraph 9.1.3 including authorized adjustments thereto.
- 9.1.2 The date of commencement of the Work is the date established in a Notice to Proceed (NOP) from the Owner.
- 9.1.3 The Date of Substantial Completion of the Work or designated portion thereof is the date certified by the Architect/Engineer when construction is sufficiently complete in accordance with the Contract Documents, so that the Owner can occupy or utilize the Work or designated portion thereof for the use for which it is intended.
- 9.1.4 The term Day, as used in the Contract Documents, shall mean calendar day unless otherwise specifically designated.

9.2 PROGRESS AND COMPLETION

- 9.2.1 All time limits stated in the Contract Documents are of the essence of the Contract.
- 9.2.2 The Contractor shall begin the Work on the date of commencement as defined in Subparagraph 9.1.2. He shall carry the Work forward expeditiously with adequate forces and shall achieve Substantial Completion within the Contract Time. The actual date on which the Contractor starts work will not affect the required time for completion of the work.
- 9.2.3 The Contractor shall furnish sufficient forces, plant and equipment and shall Work such hours, including night shifts and lawful overtime operations as may be necessary to ensure the execution of the Work in accordance with the Construction Schedule. If, in the opinion of the Designated Representative, the Contractor falls behind the progress schedule, the Contractor shall take such steps as may be necessary to improve its progress and shall submit its plans demonstrating the manner in which the desired rate of progress may be regained. It shall be the responsibility of the Contractor to maintain its schedule so as not to delay the progress of the project. If the Contractor delays the progress of the project, he shall, in order to maintain the overall schedule, take all necessary actions, not limited to an increase in the number of shifts, days of Work and to the extent permitted by law, to institute or increase overtime operations, all without additional cost.
- 9.2.4 If the Designated Representative determines that the Contractor, without just cause, fails or refuses to employ an adequate working force, or to employ them for a maximum number of hours per day as permitted by law or by shifts of its working forces as would be sufficient, in the opinion of the Designated Representative to complete the Work in accordance with the approved project schedule or within the time to which such completion may be extended, then after formal notice to the Contractor, the Owner shall have the right to complete or to have the Work completed by such means and in such manner, by contract or otherwise, as permitted by law, as the Owner may deem advisable, utilizing for such purpose such of the Contractor's plant, materials, equipment, tools and supplies remaining on the site. Formal notice in this article shall be telegram, or registered letter to the last known business address of the Contractor.
- 9.2.5 The expense of such completion shall be charged against and deducted out of such money as would have been payable to the Contractor if he had completed the Work; the balance of such moneys, if any, subject to the other provisions of this contract, to be paid to the Contractor without interest after completion. Should the expense of such completion, so certified by the Designated Representative, exceed the total sum which would have been payable under this contract, if the same had been completed by the Contractor or its surety, the surety shall remit such balance due to the Owner upon its demand.
- 9.2.6 Whether or not the Contractor's right to proceed is terminated, he and its surety will be liable for any damage to the Owner, other Contractors and the Designated Representative from the Contractor's refusal to complete the Work in accordance with the approved progress schedule or within the time for which such completion may be extended. Formal notice in this article shall be by telegram, or registered letter to last known business address of the Contractor.

- 9.2.7 The permitting of the Contractor or the surety on the performance bond to proceed to complete all Work or any part of it after the date of Substantial Completion or after the date to which the time for Substantial Completion may have been extended, shall in no way operate as a waiver on the part of the Owner of any of its rights hereunder.
- 9.2.8 In order to expedite the completion of the Contractor's Work, the Designated Representative may direct the Contractor to Work on the basis of two (2) shifts instead of one (1) or to take such other measures as he deems necessary to expedite construction. If the need for such direction is not attributable to delays or other fault on the part of the Contractor, the Owner shall pay the Contractor any additional net cost. If, however, the Contractor is behind schedule due to its own delays or other fault on its part and the Designated Representative directs him to Work additional shifts, expedite deliveries or purchase additional materials or equipment in order to bring its Work up to schedule, all additional costs shall be borne by the Contractor.
- 9.2.9 With the Designated Representative's approval, the Contractor shall suspend any Work that may be subject to damage by climatic conditions. Under such conditions, the Contractor shall take measures to protect the Work and to minimize the impact on the progress of the Work.

9.3 DELAYS AND EXTENSIONS OF TIME

- 9.3.1 If the Contractor is delayed at any time in the progress of the Work by any act or neglect of the Owner, Designated Representative or the Architect/Engineer or by any employee of either, or by any separate contractor employed by the Owner, or by changes ordered in the Work, or by labor disputes, fire, unusual delay in transportation, adverse weather conditions not reasonably anticipated, unavoidable casualties or any causes beyond the Contractor's control, or by delay authorized by the Owner or Designated Representative pending litigation, or by any other cause which the Designated Representative determines may justify the delay, then the Contract Time shall be extended by Change Order for such reasonable time as the Director of General Services may determine.
- 9.3.2 Any claim for extension of time shall be made in writing to the Designated Representative not more than ten (10) days after commencement of the delay; otherwise, it shall be waived. Any claim for extension of time shall state the cause of the delay and the number of days of extension requested. If the cause of the delay is continuing, only one claim is necessary, but the Contractor shall report the termination of the cause for the delay within ten (10) days after such termination and shall simultaneously make final claim for said delay, otherwise any claim for extension of time based upon that cause shall be waived.
- 9.3.3 In the event of a delay attributable in part to the Contractor and in part to causes for which the Contractor is not responsible, then provided the Contractor has given proper and timely notice hereunder, the delay shall be equitably apportioned among the parties causing it and the Contractor shall remain liable for the portion not so excused.
- 9.3.4 If no agreement is made stating the dates upon which interpretations as set forth in Subparagraph 3.2.2 shall be furnished, then no claim for delay shall be allowed on account of failure to furnish such interpretations until fifteen days after written request is made for them and not then, unless such claim is reasonable.
- 9.3.5 If the Project is delayed as a result of the Contractor's refusal or failure to begin the Work on the date of commencement, as defined in Subparagraph 9.1.2, or its refusal or failure to carry the Work forward expeditiously with adequate forces, equipment, material or other resources, the Contractor shall be liable to the Owner for damages for every day Contractor's scheduled completion is exceeded, provided, however, that such refusal or failure is not the result of a justifiable delay as defined in Subparagraph 9.3.1.
- 9.3.6 Neither the Owner, Architect/Engineer, nor Designated Representative shall have liability to the Contractor nor to any other Contractor or subcontractor for delay, hindrance or interference in the performance of the Work, however caused, except for delay or hindrance resulting from active interference of the Owner or its representatives in such Contractor's execution of the Work.
- 9.3.7 In addition to damages, as defined in Subparagraph 9.3.5, the Contractor shall be liable to the Owner for any damages sustained as the result of the Contractor's refusal or failure to perform the Work, provided however that such refusal or failure is not the result of a justifiable delay as defined in Subparagraph 9.3.1.
- 9.3.8 Contractor shall not request additional time to complete the project because of delays occurring on Sundays or holidays. Neither shall he request additional time for Saturday delays except and unless he can show proof of normally working on Saturdays in order to complete the Work on time.
- 9.3.9 Anticipated Normal Weather Days: The time estimated by the Contractor for completion of the entire Work ready for use shall include the number of calendar days, for anticipated delays due to normal weather conditions. No time extensions for delays due to weather will be allowed until and unless such delays exceed the time included for normal weather delays. In case of claims for extension of time because of abnormal inclement weather, such extension of time shall be granted only because such abnormal inclement weather prevented the execution of major items of Work on normal working days. A weather table reflecting the meteorological data from the Santa Barbara area is given following the General Conditions and will be used to determine any contract time extension due to abnormally inclement weather. For the purpose of this contract, "abnormal inclement weather" will be interpreted as the number of days in excess of the normal on which rainfall exceeds 0.01 inch or snow/ice pellets exceed 1.0 inch. Extension of time to complete the project will be based on actual working days, i.e., Saturdays, Sundays and holidays will be considered in granting extension of time.

- 9.3.10 Liquidated Damages: The Owner will suffer financial loss if the project is not substantially complete on the date set forth in the Contract Documents. The Contractor and its surety shall be liable for and pay to the Owner, hereinafter stipulated as fixed, agreed and liquidated damages for each consecutive calendar day of delay until the Work is substantially complete, the sum noted in the Notice to Bid. The Owner reserves the right to withhold the liquidated damages, incurred because of failure to complete the project on time, from the final payment to the Contractor. The Owner reserves the right to withhold liquidated damages from any progress payments occurring after the contract completion date.
- 9.3.11 If a suspension of work is ordered by the Designated Representative, due to the failure on the part of the Contractor to carry out orders given or to perform any provision of the contract, the days on which the suspension order is in effect shall be considered working days if such days are working days as defined.

ARTICLE 10: PAYMENTS AND COMPLETION

10.1 CONTRACT SUM

- 10.1.1 The Contract Sum is stated in the Agreement between the Owner and the Contractor including adjustments thereto and is the total amount payable to the Contractor for the performance of the Work under the Contract Documents.
- 10.1.2 Payment for work performed or materials furnished under an assessment proceedings contract will be made as provided in the particular proceedings or legislative act under which such contract was awarded.
- 10.1.3 Whenever any portion of the work is performed by the Owner at the Contractor's request, the cost thereof shall be charged against the Contractor, and may be deducted from any amount due or becoming due from the Owner.

10.2 SCHEDULE OF VALUES

- 10.2.1 Within **fifteen (15) days** after award of the contract and at least fifteen (15) days before the first Application for Payment, the Contractor shall submit to the Designated Representative a schedule of values allocated to the various portions of the Work prepared in such a form and supported by such data to substantiate its accuracy as the Designated Representative may require. This schedule, unless objected to by the Designated Representative, shall be used only as a basis for the Contractor's Application for Payment.
- 10.2.2 The schedule of values shall equal in total the Contract Sum and shall correctly represent a reasonable apportionment of the Contract Sum.
- 10.2.3 When a bid item is included in the proposal form and subject to the limitation and conditions in the contract documents, the Contractor shall itemize in the schedule of values the costs of mobilization work in advance of construction operations and not directly attributed to any specific bid item. When no such bid item is provided, payment for mobilization costs will be considered in the other items of work.
- 10.2.4 With said Schedule of Values contractor shall provide to Owner's Designated Representative copies of hourly wage rates for all workers in all trades associated with the job. If, during the course of construction, wage rates change, the contractor shall provide to Owner's Designated Representative copies of revised hourly wage rates the same day as said change is adopted or agreed-upon.

10.3 APPLICATION FOR PAYMENT

- 10.3.1 The Designated Representative will, after award of the contract, establish a closure date for the purpose of making monthly progress payments. The Contractor may request in writing that such monthly closure date be changed. The Designated Representative may approve such request when it is compatible with the Owner's payment procedures.
- 10.3.1.1 Each month, the Contractor will make an approximate measurement of the work performed to the closure date and as a basis for making monthly payments, estimate its value based on the contract unit prices or as provided for in the approved schedule of values.
- 10.3.1.2 At a fixed date each month as established by the Designated Representative during the progress of the Work, the Contractor shall render to the Designated Representative a notarized Application for Payment for a portion of the Contract Price, broken down into the categories itemized in the Contractor's Schedule of Values. The amounts invoiced shall be directly proportional to the percentage of completion of Work in each of the categories at the end of the closure date for the invoice period less any amounts previously invoiced. The Application for Payment shall be made on A.I.A. Document G702 with continuation sheets A.I.A. Document G703, or on other forms approved by the Designated Representative.
- 10.3.2 The Contractor shall certify monthly that he has made payment due to its Subcontractors and suppliers from the proceeds of prior payments and that he will make timely payments from the proceeds of the progress payment now due to its Subcontractor and suppliers in accordance with the contractual arrangements with them. The Contractor shall submit written certification that all amounts for equipment, materials, labor, union benefits and other services and all other items provided by the month covered by Contractor's invoice have been paid; and proof that Contractor has acquired title to the equipment and materials invoiced the previous month. Partial Waivers of Lien will be

required with the second and succeeding monthly invoices. The Designated Representative may request Record Documents, schedule updates, payrolls for all labor and other data supporting payment to Subcontractors and material suppliers before processing the requisition.

- 10.3.3 With respect to material purchased during the preceding month by the Contractor as Owner's special purchasing subagent, the Contractor shall provide the Designated Representative with a statement showing the costs of such materials and any state or local sales and use taxes paid by the Contractor in connection with the purchase or use thereof during the preceding month, which statement shall be supported by copies of invoices, receipts, etc., clearly and separately showing the costs of such materials and taxes. This statement shall be filed with the Designated Representative within one month after the purchase of such items.
- 10.3.4 Unless otherwise provided in the Contract Documents, payment will be made on account of materials or equipment not incorporated in the Work but delivered and suitably stored at the site. Payments made for materials or equipment stored on the site shall be conditioned upon submission by the Contractor of bills of sale or such other procedures satisfactory to the Designated Representative to establish the Owner's title to such materials or equipment or otherwise protect the Owner's interest. Materials invoiced in pay applications, if not stored on site, must be kept stored in a bonded warehouse approved by the Designated Representative.
- 10.3.5 The Contractor warrants that title to all Work, materials and equipment covered by an Application for Payment will pass to the Owner by incorporation in the construction and upon the receipt of final payment by the Contractor free and clear of all liens, claims, security interests or encumbrances, hereinafter referred to in this Article 10 as "liens" and that no Work, materials or equipment covered by an Application for Payment will have been acquired by the Contractor by any other person performing its Work at the site or furnishing materials and equipment for its Work, subject to an agreement under which an interest therein or an encumbrance thereon is retained by the seller or otherwise imposed by the Contractor or such other person. All Subcontractors and Sub-subcontractors agree that title will so pass upon their receipt of payment from the Contractor.

10.4 PROGRESS PAYMENTS

- 10.4.1 If the Contractor has made Application for Payment in accordance with the General Requirements, the Designated Representative will, with reasonable promptness, review and process such Application for Payment in accordance with the Contract. From each progress estimate, five (5%) percent will be deducted and retained by the Owner, and the remainder less the amount of all previous payments will be paid to the Contractor.
- 10.4.2 No approval of an application for a progress payment, nor any progress payment, nor any partial or entire use or occupancy of the project by the Owner, shall constitute an acceptance of any Work not in accordance with the Contract Documents. Nor shall the same relieve the Contractor or its surety from any obligation under the Contract or the Standard Performance Bond and the Standard Labor and Material Payment Bond.
- 10.4.3 Except in case of bona fide disputes, or where the Contractor has some other justifiable reason for delay, the Contractor shall pay for all transportation and utility services not later than the end of the calendar month following that in which services are rendered and for all materials, tools and other expendable equipment to the extent of ninety percent (90%) of the cost thereof not later than the end of the calendar month following that in which such materials, tools and equipment are delivered at the site of the Project. The Contractor shall pay to each of its Subcontractors, not later than the end of the calendar month in which each payment is made to the Contractor, the representative amount allowed the Contractor on account of the Work performed by its Subcontractors, to the extent of each Subcontractor's interest herein. The Contractor shall, by an appropriate agreement with each Subcontractor, also require each Subcontractor to make payments to its suppliers and sub-subcontractors in a similar manner.
- 10.4.4 Payment shall not relieve the Contractor from its obligations under the contract; nor shall such payment be construed to be acceptance of any of the work. Payment shall not be construed as the transfer of ownership of any equipment or materials to the Owner. Responsibility of ownership shall remain with the Contractor who shall be obligated to store, protect, repair, replace, rebuild or otherwise restore any fully or partially completed work or structure for which payment has been made; or replace any materials of equipment required to be provided under the contract which may be damaged, lost, stolen or otherwise degraded in any way prior to acceptance of the work under the contract, except as provided in Paragraph 10.7.2.
- 10.4.4.1 Guarantee periods shall not be affected by any payment but shall commence on the date equipment or material is placed into service at the direction of the Owner. In the event such items are not placed into service prior to partial or final acceptance of the project, the guarantee period will commence on the date of such acceptance.
- 10.4.4.2 If, within the time fixed by law, a properly executed notice to stop payment is filed with the Owner, due to the Contractor's failure to pay for labor or materials used in the work, all money due for such labor or materials will be withheld from payment to the Contractor in accordance with applicable laws.
- 10.4.5 Per the California Public Contract Code, upon the Contractor's request, the County will make payment of funds withheld to ensure performance of the Contract if the Contractor deposits in escrow with the Santa Barbara County Treasurer, or with a bank acceptable to the COUNTY/DISTRICT, securities eligible for investment under Government Code Section 16430 or bank or savings and loan certificates of deposit, upon the following conditions:

- (a.) The Contractor shall bear the expense of the COUNTY/DISTRICT and the escrow agent, either the County

Treasurer or the bank, in connection with escrow deposit made.

- (b.) Securities or certificates of deposit to be placed in escrow shall be of a value at least equivalent to the amount of retention to be paid to the Contractor pursuant to this section.
- (c.) The Contractor shall enter into an escrow agreement satisfactory to the COUNTY/DISTRICT which agreement shall include provisions governing inter alia:
 - (1) the amount of securities to be deposited.
 - (2) the providing of power of attorney or other documents necessary for the transfer of the securities to be deposited.
 - (3) conversion to cash to provide funds to meet defaults by the Contractor including, but not limited to, termination of the Contractor's control over the work, stop notices filed pursuant to law, assessment of liquidated damages or other amounts to be kept or retained under the provisions of the contract.
 - (4) decrease in value of securities on deposit.
 - (5) the termination of the escrow upon completion of the Contract.
- (d.) The Contractor shall obtain the written consent of the surety of such agreement.

10.5 PAYMENTS WITHHELD

10.5.1 The Designated Representative, Architect/Engineer or the Owner may decline approval of an Application for Payment if, in its opinion, the Application is not adequately supported. If the Contractor and the Designated Representative or Owner cannot agree on a revised amount, the Designated Representative shall process the application for the amount he deems appropriate. An amount equaling one hundred fifty (150%) percent of the value of the Work related to any Stop Notice shall be withheld from payments applied for by the Contractor until the Stop Notice is expunged. The Designated Representative may also decline to approve any Applications for Payment or, because of subsequently discovered evidence or subsequent inspections, he may nullify in whole or in part any approval previously made to such extent as may be necessary in its opinion because of:

- (a.) Defective Work not remedied.
- (b.) Third party claims filed or reasonable evidence indicating probably filing of such claims.
- (c.) Failure of the Contractor to make payments properly to Subcontractor or for labor, materials or equipment. (d.) Reasonable evidence that the Work cannot be completed for the unpaid balance of the Contract Sum. (e.) Damage to the Designated Representative, the Owner or another contractor working at the Project.
- (f.) Reasonable evidence that the Work will not be completed within the Contract Time. (g.) Persistent failure to carry out the Work in accordance with the Contract Documents.
- (h.) The filing of a lien against the Project when lien is caused by the act or inaction of the Contractor or its subcontractor. (i.) Refusal to follow the Project Safety Program issued as a Contract Document.
- (j.) Failure to maintain records as specified.
- (k.) Failure to maintain record drawings as specified. (l.) Failure to secure required building inspections.

10.5.2 When the above grounds in Subparagraph 10.5.1 are removed, payment shall be made for the amounts withheld because of them, but in no case shall interest be paid on amounts withheld by the Owner to the Contractor.

10.6 FAILURE OF PAYMENT

10.6.1 If the Contractor is not paid within sixty (60) days after the Application for Payment is approved for payment by the Designated Representative and has become due and payable, then the Contractor may, upon thirty (30) additional days written notice to the Owner and the Designated Representative, stop the Work until payment of the amount owing has been received. The Contract Sum shall be increased by the amount of the Contractor's reasonable costs of shutdown, delay and start up, which shall be affected by the appropriate Change Order in accordance with Paragraph 13.3., but in no case shall interest be paid by the Owner to the Contractor.

10.7 SUBSTANTIAL COMPLETION

10.7.1 When the Contractor considers that the Work, or a designated portion thereof which is acceptable to the Owner, is substantially complete as defined in Subparagraph 9.1.3, the Contractor shall prepare for submission to the Designated Representative a list of items to be completed or corrected. The failure to include any items on such list does not alter the responsibility of the Contractor to complete all Work in accordance with the Contract Documents. When the Designated Representative and Architect/Engineer, on the basis of inspection, determine that the Work or designated portion thereof is substantially complete, the Architect/Engineer will then prepare a Certificate of Substantial Completion which shall establish the Date of Substantial Completion, shall state the responsibilities of the Owner, the Designated Representative and the Contractor for security, maintenance, heat, utilities, damage to the Work, insurance and shall fix the time within which the Contractor shall complete the items listed therein. Warranties required by the Contract Documents shall commence on the Date of Substantial Completion of the Work or designated portion thereof unless otherwise provided in the Certificate of Substantial Completion. The Certificate of Substantial Completion shall be submitted to the Owner, the Designated Representative and the Contractor for their written acceptance of the responsibilities assigned to them in such Certificate. The Owner may retain a sum equal to an amount not to exceed one hundred twenty-five percent (125%) of the estimated cost of completing any unfinished items, separately listed and estimated at the time of substantial

completion. Thereafter, the Owner shall pay to the Contractor monthly, the amount retained for incomplete items as each of said items are completed.

- 10.7.2 The Owner shall have the right to take possession of and use for any purpose any partially completed portion of the Work. The Designated Representative will give notice to the Contractor of the Owner's intention to take said possession and use. Such taking possession or use shall not be deemed to be the Designated Representative's acknowledgement of completion and acceptance of said portion of Work.
- 10.7.2.1 The Owner's taking over and utilizing all or part of any completed facility or appurtenance will relieve the Contractor of responsibility for injury or damage to said completed portions of the improvement resulting from use by the public or from the action of the elements or from any other cause, except injury or damage resulting from the Contractor's operations or negligence. The Contractor will not be required to reclean such portions of the improvements before final acceptance, except for cleanup made necessary by its operations. Nothing in this section shall be construed as relieving the Contractor from full responsibility for correcting defective work or materials.
- 10.7.2.2 In the event the Owner exercises its right to place into service and utilize all or part of any completed facility or appurtenance, the Owner shall assume the responsibility and liability for injury to persons or property arising out of or resulting from the utilization of the facility or appurtenance so placed into service, except for any such injury to persons or property caused by any willful or negligent act or omission of the Contractor, subcontractor, their officers, employees or agents.

10.8 FINAL COMPLETION AND FINAL PAYMENT

- 10.8.1 Following the Architect/Engineer's issuance of the Certificate of Substantial Completion of the Work or designated portion thereof and the Contractor's completion of the Work, the Contractor shall notify the Designated Representative in writing that the Work will be ready for final inspection and test on a definite date. Notice shall be given at least **five (5)** days in advance of said date. Designated Representative shall forward the notice to the Architect/Engineer who will attach its endorsement as to whether or not he concurs with the Contractor's statement that the Work will be ready for final inspection or test on the date given, but such endorsement shall not relieve the Contractor of its responsibility in the matter. If the Architect/Engineer concurs that the Work will be ready for final inspection or test on the date given, the Architect/Engineer and the Designated Representative will make such inspection. The Contractor is required to furnish access for the final inspection as provided in Subparagraph 3.2.1. If the Work is found acceptable under the Contract Documents and the Contractor fully performed the Designated Representative, upon receipt of a correct final Application for Payment, shall recommend to the Owner that such payment be made.
- 10.8.2 Neither the final payment nor the remaining retained percentage shall become due until the Contractor submits to the Designated Representative all (1) inspection sign-offs, (2) final certificate of occupancy, (3) an affidavit that all payrolls, bills for materials and equipment and other indebtedness connected with the Work for which the Owner or its property might in any way be responsible, have been paid or otherwise, (4) consent of surety, if any, to final payment and executed "General Release and Lien Waiver and General Guarantee", on forms to be provided by the Designated Representative, (5) if required by the Owner, other data establishing payment or satisfaction of all such obligations, such as receipts, releases and waivers of liens arising out of the contract, to the extent and in such form as may be designated by the Owner or Designated Representative. If any Subcontractor refuses to furnish a release or waiver required by the Owner or Designated Representative, the Contractor may furnish a bond satisfactory to the Owner and Designated Representative to indemnify them against any such lien. If any such lien remains unsatisfied after all payments are made, the Contractor shall refund to the Owner or Designated Representative all monies that the latter may be compelled to pay in discharging such lien, including all costs and reasonable attorney's fees. Contractor is required to submit all "Record Documents" and operating manuals as required by the Contract Documents prior to the processing of the final payment.
- 10.8.3 If, after Substantial Completion of the Work, final completion thereof is materially delayed through no fault of the Contractor or by the issuance of Change Orders affecting the final completion, and the Designated Representative so confirms, the Owner shall upon certification by the Designated Representative and without terminating the Contract, make payment of the balance due for that portion of the Work fully completed and accepted. If the remaining balance of Work not fully completed or corrected is less than the retention stipulated in the Contract Documents and if the bonds have been furnished as provided in Paragraph 8.5, the written consent of the surety to the payment of the balance due for that portion of the Work fully completed and accepted shall be submitted by the Contractor to the Designated Representative prior to such payment. Such payment shall be made under the terms and conditions governing final payment, except that it shall not constitute a waiver of claims.
- 10.8.4 Upon successful completion of the final inspection and Work required by the Contract, acceptance of the same by the Owner and the filing of all affidavits, consents of surety and other data required in Subparagraph 10.8.2 and the submission of all bonds, written warranties and guarantees and of all data documents required for project closeout by the Contract Documents, the Architect/Engineer shall file a written certification of completion with the Owner and with the Designated Representative as to the entire amount of Work performed and compensation earned, including extra Work and compensation therefore. At the expiration of thirty-five (35) days after the Owner's confirmation of such Certificate of Completion or as prescribed by law, the Owner shall pay the Contractor the amount stated therein, less all prior payments and advances, whatsoever, to or for the account of the Contractor except such amounts as are required to be withheld by properly executed and filed notices to stop payment or as may be authorized by the contract to be further retained. All prior estimates and payments including those relating to extra Work shall be subject to correction by this payment, which is throughout the Contract called "Final Payment."

10.8.5 The making of Final Payment shall constitute a waiver of all claims by the Owner or Designated Representative except those arising from:

- (a.) Unsettled liens.
- (b.) Faulty or defective Work appearing after Substantial Completion.
- (c.) Failure of the Work to comply with the requirements of the Contract Documents (d.) Terms of any special warranties required by the Contract Documents.

10.8.5.1 The acceptance by the Contractor of the Final Payment shall be and operate as a release to the Owner and to the Designated Representative of all claims and of all liability to the Contractor for all things done or furnished in connection with this Contract.

10.8.6 In accordance with Section 4551 of the Government Code, the Contractor and subcontractors shall conform to the following requirements. In entering into a public works contract or a subcontract to supply goods, services, or materials pursuant to a public works contract, the Contractor or subcontractor offers and agrees to assign to the awarding body all rights, title and interest in and to all causes of action it may have under Section 4 of the Clayton Act (15 U.S.C. Sec. 15) or under the Cartwright Act, Chapter 2 (commencing with Section 16700) of Part 2 of Division 7 of the Business and Professions Code, arising from purchases of goods, services, or materials pursuant to the public works contract of the subcontract. This assignment shall be made and become effective at the time the awarding body tender's final payment to the Contractor, without further acknowledgment by the parties.

10.8.7 In accordance with Section 4552 of the Government Code, the bidder shall conform to the following requirements. In submitting a bid to a public purchasing body, the bidder offers and agrees that if the bid is accepted, it will assign to the purchasing body all rights, title, and interest in and to all causes of action it may have under Section 4 of the Clayton Act, Chapter 2 (commencing with Section 16700) of Part 2 of Division 7 of the Business and Professions Code, arising from purchases of goods, materials, or services by the bidder for sale to the purchasing body pursuant to the bid. Such assignment shall be made and become effective at the time the purchasing body tender's final payment to the bidder.

10.9 MEASUREMENT OF QUANTITIES FOR UNIT PRICE WORK

10.9.1 General: Unless otherwise specified, quantities of work shall be determined from measurements or dimensions in horizontal planes. However, linear quantities of pipe, piling, fencing, and timber shall be considered as being the true length measured along the longitudinal axis. Unless otherwise provided in the Contract Documents, volumetric quantities shall be the product of the mean area of vertical or horizontal sections and the intervening horizontal or vertical dimension. The planimeter shall be considered an instrument of precision adapted to the measurement of all areas.

10.9.2 Methods of Measurement: Materials and items of work which are to be paid for on the basis of measurement shall be measured in accordance with the methods stipulated in the particular section involved.

10.9.3 Certified Weights: When payment is to be made on the basis of weight, the weighing shall be done on certified platform scales or, when approved by the Designated Representative, on a completely automated weighing and recording system. The Contractor shall furnish the Designated Representative with duplicate licensed weighmaster's certificates showing the actual net weights. The Designated Representative will accept the certificate as evidence of the weights delivered.

10.9.4 Units of Measurement: Measurements shall be in accordance with U. S. Standard Measures. A pound is an avoirdupois pound. A ton is 2,000 pounds avoirdupois. The unit of liquid measure is the U. S. gallon.

10.9.5 Lump Sum Items: Items for which quantities are indicated as "Lump Sum", "L.S.", "Job", or words of like import shall be paid for at the price named. Such payment shall be full compensation for the work named and all work appurtenant thereto required by the contract which is not specifically provided for by other pay items.

10.9.6 Actual Quantities: The quantities listed in the bid schedule will not govern final payment. Payment to the Contractor will be made only for the actual quantities of contract items constructed in accordance with the plans and specifications. Upon completion of the construction, if the actual quantities show either an increase or decrease from the quantities given in the bid schedule, the contract unit prices will prevail subject to the provisions of Article 13.

10.9.7 Waste: Payment will not be made for materials wasted or disposed of in a manner not called for under the Contract. This includes rejected materials not unloaded from vehicles, material rejected after it has been placed and material placed outside of the plan lines. No compensation will be allowed for disposing of rejected or excess material.

ARTICLE 11: PROTECTION OF PERSONS AND PROPERTY

11.1 SAFETY PRECAUTIONS AND PROGRAMS

11.1.1 The Contractor expressly undertakes, both directly and through its Subcontractor, to take every precaution at all times for the protection of persons, including employees and property. The Contractor shall be responsible for initiating, maintaining and supervising all safety precautions and programs in connection with the Work.

- 11.1.2 The Contractor shall comply with the provisions of the "Construction Safety Act" and the "Occupational Safety and Health Act of 1970" and the Designated Representative's safety program, as well as all other applicable, Federal, State and local requirements. The Contractor shall submit its safety program to the Designated Representative prior to mobilizing the job and shall be responsible for the safety, efficiency and adequacy of its plant, appliances and methods and for any damage which might result from failure or improper construction, maintenance or operation. The Contractor shall provide a safety report to the Designated Representative on a weekly basis. During the conduct of the Work, the Contractor shall take immediate corrective action, as required upon notification of any deficiencies in safety provisions by the Designated Representative or identification of any deficiencies by Subcontractor personnel.
- 11.1.3 If the Contractor fails to maintain the safety precautions required by law or directed by the Designated Representative, the Designated Representative may take such steps as necessary and charge the Contractor therefore.
- 11.1.4 The failure of the Owner to take any such action shall not relieve the Contractor of its obligations in Subparagraph 11.1.1.
- 11.1.5 The Contractor shall immediately notify the Designated Representative of all accidents and submit a written report describing in detail the circumstances of all accidents within twenty-four (24) hours.
- 11.1.6 The Contractor alone shall be responsible for the safety, efficiency and adequacy of its plant, appliances and methods and for any damage which may result from their failure or their improper construction, maintenance or operation.

11.2 SAFETY OF PERSONS AND PROPERTY

- 11.2.1 The Contractor shall take all reasonable precautions for the safety of and shall provide all reasonable protection to prevent damage, injury or loss to:
- (a.) All employees on the Project and all other persons who may be affected thereby;
 - (b.) All the Work and all materials and equipment to be incorporated therein, whether in storage on or off the site, under the care, custody or control of the Contractor or any of its Subcontractors or Sub-subcontractors; and
 - (c.) Other property at the site or adjacent thereto, including trees, shrubs, lawns walk, pavements, roadways, structures and utilities not designed for removal, relocation or replacement in the course of construction.
- 11.2.2 The Contractor shall give all notices and comply with all applicable laws, ordinances, rules, regulations and lawful orders of any public authority bearing on the safety of persons or property or their protection from damage, injury or loss.
- 11.2.3 The Contractor shall erect and maintain, as required by existing conditions and progress of the Work, all reasonable safeguards for safety and protection, including posting danger signs and other warnings against hazards promulgating safety regulations and notifying the Owners and users of adjacent utilities. He shall protect the Owner's property from injury or loss arising in connection with this Contract. He shall adequately protect adjacent property as provided by law and the Contract Documents. He shall provide and maintain all passageways, guard fences, light and other facilities for protection required by public authority, local conditions or any of the Contract Documents. If the Contractor fails to so comply, he shall, at the direction of the Designated Representative, remove all forces from the Project without cost or loss to the Owner or Designated Representative, until he complies.
- 11.2.4 When the use or storage of explosives or other hazardous materials or equipment is necessary for the execution of the Work, the Contractor shall exercise the utmost care and shall carry on such activities under the supervision of properly qualified personnel.
- 11.2.5 The Contractor shall notify the Designated Representative of any flammable, combustible and toxic materials intended for use on the project and shall furnish the Designated Representative literature pertinent to the use and control of such materials.
- 11.2.6 Every employee will be dressed for the Work he performs. Minimum dress will consist of long pants, tee shirt and work shoes. Shorts, cut-offs, "tank-top" shirts or soft-soled shoes will not be permitted.
- 11.2.7 The Contractor shall promptly remedy all damage or loss (other than damage or loss insured under Paragraph 12.2) to any property, referred to under Articles 11.2.1.2 and 11.2.1.3, caused in whole or in part by the Contractor, its Subcontractors or anyone directly or indirectly employed by any of them, or by anyone for whose acts any of them may be liable and for which the Contractor is responsible under the Articles 11.2.1.2 and 11.2.1.3, except damage or loss attributable to the acts or omissions of the Owner or Architect/Engineer or anyone directly or indirectly employed by either of them or by anyone for whose acts either of them may be liable and not attributable to the fault or negligence of the Contractor. The foregoing obligations of the Contractor are in addition to its obligations under Paragraph 5.18. The Contractor shall be responsible to the Owner and the Designated Representative for the acts and omissions of all its employees and all Subcontractors, their agents and employees and all other persons performing any of the Work under a contract with the Contractor.

- 11.2.8 The Contractor and each Subcontractor shall designate a responsible member of its organization at the site to act as its Safety Representative whose duty shall be the prevention of accidents and who shall be responsible to maintain all Safety requirements of the Contractor and shall attend all Project Safety Meetings scheduled by the Contractor. This person shall be the Contractor's or Subcontractor's Superintendent unless otherwise designed by the Contractor in writing to the Designated Representative.
- 11.2.9 The Contractor shall not load or permit any part of the Work to be loaded so as to endanger safety.
- 11.2.10 When necessary for the proper protection of the Work, temporary heating of a type approved by the Designated Representative and Architect/Engineer shall be provided by the Contractor unless otherwise specified.

11.3 EMERGENCIES

- 11.3.1 In an emergency affecting the safety or life of individuals, of the Work, or of adjoining property, the Contractor without special instruction or authorization from the Owner or Designated Representative or Architect/Engineer shall act, at its discretion, to prevent such threatened loss or injury. Also, should he, to prevent threatened loss or injury, be instructed or authorized to act by the Owner or Designated Representative or Architect/Engineer, he shall so act, without appeal. Any additional compensation or extension of time claimed by the Contractor on account of any emergency Work shall be determined as provided by Article 13 - Changes in the Work.
- 11.3.2 Whenever immediate action is required to prevent impending injury, death, or property damage, and precautions which are the Contractor's responsibility have not been taken and are not reasonably expected to be taken, the Owner or Designated Representative may, after reasonable attempt to notify the Contractor, cause such precaution to be taken and shall charge the cost thereof against the Contractor, or may deduct such cost from any amount due or becoming due from the Owner. The Owner's or Designated Representative's action or inaction under such circumstances shall not be construed as relieving the Contractor or its surety from liability.

ARTICLE 12: UTILITIES

12.1 LOCATION

- 12.1.1 The Owner will search known substructure records and furnish the Contractor, when requested by the Contractor, with copies of documents which describe the location of utility substructures, or will indicate on the plans for the project those substructures, except for service connections, which may affect the work. Information regarding removal, relocation, abandonment, or installation of new utilities will be furnished to prospective bidders.
- 12.1.2 Where underground main distribution conduits such as water, gas, sewer, electric power, telephone or cable television are shown on the plans, the Contractor, for the purpose of preparing its bid, shall assume that every property parcel will be served by a service connection for each type of utility.
- 12.1.3 At least two (2) working days before entering on the work, the Contractor shall request the utility owners whose utilities will be affected by the Contractor's work to mark or otherwise indicate the approximate location of their subsurface facilities including, but not limited to, structures, main conduits and service connections. This requirement will not apply to sewer and storm drain installations where their location and depth are shown on the plans for the project.
- 12.1.4 It shall be the Contractor's responsibility to determine the location and depth of all utilities, including service connections, which have been marked by the respective utility owners and which he believes may affect or be affected by its operations. If no pay item is provided in the contract for this work, full compensation for such work shall be considered as included in the prices bid for other items of work.

12.2 PROTECTION

- 12.2.1 The Contractor shall not interrupt the service function or disturb the supporting base of any utility without authority from the utility owner or order from the Designated Representative.
- 12.2.2 Where protection is required to insure support of utilities located as shown on the plans or in accordance with Paragraph 12.1, the Contractor shall, unless otherwise provided, furnish and place the necessary protection at its expense.
- 12.2.3 Upon learning of the existence and location of any utility omitted from or shown incorrectly on the plans, or not properly marked, the Contractor shall immediately notify the Designated Representative in the form of a written request for information. When authorized by the Owner, support or protection of the utility will be paid for as provided in Article 13.
- 12.2.4 The Contractor shall immediately notify the Designated Representative and the utility owner if any utility is disturbed. The Contractor shall bear the costs of repair or replacement of any utility damaged.
- 12.2.5 When placing concrete around or contiguous to any non-metallic utility installation, the Contractor at its own expense, shall (1) furnish and install a two-inch cushion of expansion joint material or other similar resilient material; or (2) provide a sleeve or other opening which will result in a two-inch minimum clear annular space between the

concrete and the utility; or (3) provide other acceptable means to prevent embedment in or bonding to the concrete. Where concrete is used for backfill or for structures which would result in embedment, or partial embedment, of a metallic utility installation; or where the coating, bedding or other cathodic protection system is exposed or damaged by the Contractor's operations or as may be required by the work, the Contractor shall notify the Designated Representative and arrange to secure the advice of the affected utility owner regarding the procedures required to maintain or restore the integrity of the system.

12.3 **EXCAVATIONS**

12.3.1 For any displacement or excavation of the ground that may be required by any performance under this Contract, the Contractor shall obtain an inquiry identification number by calling Underground Service Alert (USA) 1 (800) 422- 4133 or by such other means as may be required; shall conform to all requirements of Government Code Sections 4215 through 4217 regarding any such displacement or excavation, including the payment of any fees required; and shall facilitate performance by the Owner of any obligation required of the County under said sections.

12.3.2 There shall be no performance under this Contract by either party unless and until the provisions of such Sections are complied with and the Designated Representative is notified regarding the compliance.

12.4 **REMOVAL**

12.4.1 Unless otherwise specified, the Contractor shall remove all interfering portions of utilities shown on the plans or indicated in the bid documents as "abandoned" or "to be abandoned in place".

12.4.2 Before starting removal operations, the Contractor shall ascertain from the Designated Representative whether the utility abandonment is complete, and the costs involved in the removal and disposal shall be absorbed in the bid for the items of work necessitating such removals.

12.5 **RELOCATION**

12.5.1 When feasible, the utility owners responsible for utilities within the area affected by the work will complete their necessary installations, relocations, repairs or replacements before commencement of work by the Contractor. When the Contract Documents or plans indicate that a utility installation is to be relocated, altered or constructed by others, the Owner will conduct all negotiations with the utility owners and the work will be done at no cost to the Contractor.

12.5.2 Utilities which are relocated in order to avoid interference with the proposed permanent work shall be protected in their relocated position and the cost of such protection shall be absorbed in the various items of the contract.

12.5.3 After award of the contract, portions of utilities which are found to interfere with the work will be relocated, altered or reconstructed by the utility owners, or the Owner may order changes in the work to avoid interference. Such changes will be paid for in accordance with Article 13.

12.5.4 When the plans or specifications provide for the Contractor to alter, relocate, or reconstruct a utility, all costs for such work shall be included in the bid for the items of work necessitating such work. Temporary or permanent relocation or alteration of utilities requested by the Contractor for its own convenience shall be its responsibility, and he shall make all arrangements and bear all costs.

12.5.5 The utility owner will relocate service connections as necessary within the limits of the work or within temporary construction or slope easements unless otherwise specified. When directed by the Designated Representative, the Contractor shall arrange for the relocation of service connections as necessary between the meter and property line, or between a meter and the limits of temporary construction or slope easements. The relocation of such service connections when not detailed on the plans or in the specifications will be paid for in accordance with provisions of Article 13. Payment will include the restoration of all existing improvements which may be affected thereby. The Contractor may, for its own convenience or to expedite the work, agree with any utility owner to disconnect and reconnect interfering service connections. The Owner will not be involved in any such agreement.

12.6 **DELAYS**

12.6.1 The Contractor shall notify the Designated Representative of its construction schedule insofar as it affects the protection, removal or relocation of utilities. Said notification shall be in writing and shall be included as a part of the construction schedule required in Paragraph 5.10. He shall notify the Designated Representative in writing of any subsequent changes in its construction schedule which will affect the time available for protection, removal or relocation of utilities.

12.6.2 The Contractor will not be entitled to damages or additional payment for delays attributable to utility relocations or alterations if correctly located, noted and completed in accordance with Paragraph 12.1. The Contractor may be given an extension of time for unforeseen delays attributable to utility relocations or alterations not shown or incorrectly shown on the plans, or for unreasonably protracted interference by utilities in performing work correctly shown on the plans. If the Contractor sustains loss due to delays attributable to interferences, relocations or alterations not covered by Paragraph 12.1, which could not have been avoided by the judicious handling of forces, equipment or plant, there shall be paid to the Contractor such amount as the Owner may find to be fair and reasonable compensation for such part of the Contractor's actual loss as was unavoidable.

12.7 **COOPERATION**

12.7.1 When necessary, the Contractor shall so conduct its operations as to permit access to the work site and provide time for utility work to be accomplished during the progress of the contract work.

ARTICLE 13: CHANGES IN THE WORK

13.1 **CHANGE ORDERS**

13.1.1 A Change Order is a written order to the Contractor signed by the Owner issued after the execution of the Contract authorizing a change in the Work or an adjustment in the Contract Sum or the Contract Time. The Contract Sum and the Contract Time may be changed only by a Change Order. The County Director of General Services is authorized to execute Change Orders for the Owner in accordance with Article 2.3. A Change Order signed by the Contractor indicates its agreement therewith, including the adjustment in the Contract Sum or the Contract Time, and Contractor agrees that the change in the contract sum and contract time set forth in the Change Order shall constitute the complete compensation and time extension for the change in the work including, but not limited to, Contractor's field and home office overhead, profit, and supervision costs. The Contractor shall not proceed with any change in the Work unless directed in writing by the Designated Representative.

13.1.2 The Owner or Designated Representative, without invalidating the Contract, may order changes in the Work within the general scope of the Contract consisting of additions, deletions or other revisions, the Contract Time being adjusted accordingly. All such changes in the Work shall be authorized by a Change Order and shall be performed under the applicable conditions of the Contract Documents. Provisions of the Contract shall apply to all changes, modifications and additions with the same effect as if changes were embodied in the base Contract Documents.

13.1.3 A change in the Work may be initiated in one of three ways:

13.1.3.1 A "Request for Quotation" form from the Designated Representative to the Contractor describing the revision to the Work desired. Usually, it is accompanied by revised drawings, sketches or other data.

13.1.3.2 Formal notification from the Contractor documenting a "concealed condition" requesting investigation by the Designated Representative and Architect/Engineer which causes changes in the Contract Documents (and a subsequent Request for Quotation on the revised documents).

13.1.3.3 In response to a Contractor's "Request for Information", the Architect/Engineers' response may include instructions which the Contractor interprets as involving "extra work." In such cases, the Contractor must submit written notice to the Designated Representative requesting review and issuance of an appropriate Request for Quotation. Any other "instruction" given to the Contractor by the Owner, Designated Representative or Architect/Engineer shall require these procedures and as indicated in 13.4.1 below.

13.1.4 The cost or credit to the Owner resulting from changes in the Work, as outlined above, shall be made on the basis of one of the following methods:

- (a.) By such applicable unit prices as set forth in the Contract Documents or subsequently agreed upon by both parties to the Contract.
- (b.) By a lump sum mutually agreed upon by the Owner and the Contractor.
- (c.) The Owner may direct the Contractor through the Designated Representative to proceed with Work on a time and material (T & M) basis, with a not to exceed cost and the Contractor shall keep and present, in such a form as the Designated Representative may direct, a correct account of all costs of the changes together with all vouchers. The costs shall include overhead and profit as subsequently set forth below. These costs then shall be finalized by a Change Order.
- (d.) If the parties cannot agree upon a Lump Sum, Unit Pricing or T & M with a not to exceed cost, the Owner may, as recommended by the Designated Representative, issue a written directive Contract Amendment to proceed and the Contractor shall be compensated for the net cost of additional Work. The Contractor shall keep and present in such a form as the Designated Representative may direct a correct account of all costs of the changes together with all vouchers. The costs shall include overhead and profit as subsequently set forth below.

13.1.5 Lump sum prices and compensation for actual net cost plus overhead and profit shall be established as follows:

13.1.5.1 The net cost of Changes in the Work may include all items of labor or material, power tools and equipment actually used, prorate charges for foreman and payroll charges such as Public Liability and Workmen Compensation Insurance. No percentage for overhead, profit and commission shall be allowed on items of premium costs for overtime, social security, old age and unemployment insurance, fringe benefits, and payroll taxes. If deductions are ordered, the credit shall be the net cost. Items considered as overhead shall include insurance, other than that mentioned above, bond or bonds, superintendent, timekeeper, clerks, watchmen, use of small tools, incidental job burdens, transportation, and general offices expense. The percentages for overhead and profit shall be negotiated and may vary according to the nature, extent and complexity of the changed Work (other than those covered by unit prices set forth on the Contract Documents), but in no case shall exceed the following:

(a.) Allowable Mark-ups on Change Orders

Definitions:

Prime Contractor = General Contractor

First Tier Contractor to the Subcontractor = Prime Contractor

Second Tier Subcontractor = Contractor to the First Tier Subcontractor

Case A: For work within the scope of the Change Order performed by forces of the Prime Contractor:

Overhead: 10% to Prime Contractor only.

Profit: 5% to Prime Contractor only.

Commission: No commission to any party.

Case B: For work within the scope of the Change Order performed by forces of the First Tier Subcontractor(s):

Overhead: 10% to First Tier Subcontractor(s) only.

Profit: 5% to First Tier Subcontractor(s) only.

Commission: 5% to Prime Contractor only.

Case C: For work within the scope of the Change Order performed by forces of the Second Tier Subcontractor(s):

Overhead: 10% to the Second Tier Subcontractor(s) only.

Profit: 5% to the Second Tier Subcontractor(s) only.

Commission: 5% to the Prime Contractor.

5% to the First Tier Subcontractor(s).

No commission to Second Tier Subcontractor(s).

(b.) Not more than four (4) mark-ups (Case C), not to exceed the maximum percentages shown above, shall be allowed. (c.) All

Cost Proposals for work shall be submitted to the Designated Representative on the attached document: "County of Santa Barbara General Services/Capital Projects Division Cost Proposal".

- 13.1.5.2 On proposals covering both increases and decreases in the amount of the contract, overhead, profit and commission shall be allowed on the net increase only as determined above. When the net difference is a deletion, no percentage for overhead profit and commission shall be allowed.
- 13.1.5.3 Contractor's cost for preparation of change order proposals shall be deemed to be included in amount of change order proposal.
- 13.1.6 The Contractor shall respond to the Designated Representative's request for a proposal within seven calendar days. In this proposal, the Contractor shall furnish to the Designated Representative an itemized breakdown of the quantities and prices used in computing the value of changes that might be ordered. The Contractor shall submit with its proposal, its request for time extension (if any). If time for completion of the Contractor's Work is not affected by the change, the Contractor shall sustain.
- 13.1.7 In figuring changes, instructions for measurements of quantities set forth in the specifications shall be followed.
- 13.1.8 After receipt of a proposal with a detailed breakdown, the Designated Representative shall act promptly thereon. However, when the necessity to proceed with a change does not allow sufficient time to properly check a proposal, the Owner through the Designated Representative may order the Contractor to proceed on the basis to be determined at the earliest practicable date. In this event, the value of the change, with the corresponding equitable adjustment to the contract, shall not be more than the increase or less than the decrease proposed.
- 13.1.9 The Designated Representative will inform the Contractor and the Contractor will inform the Designated Representative when either party recognizes that a proposed Request for Quotations (RFQ) may affect the progress of the Work schedule.
- 13.1.10 Designated Representative's Audit: Designated Representative's duly authorized auditors shall have access at all reasonable times, to all Contractor's and Subcontractors' personnel, books, records, correspondence, instructions, plans, drawings, receipts, vouchers and memoranda of every description pertaining to Change Orders for the purpose of auditing and verifying Contractor's net cost of Change Order or for any other reasonable purpose. Designated Representative's auditors shall have the right to reproduce any of the aforesaid documents. Contractor shall preserve and shall cause its Subcontractors to preserve all the aforesaid documents for a period of two (2) years after the completion and acceptance or termination of the Work.
- 13.1.11 If unit prices are stated in the Contract Documents or subsequently agreed upon and if the quantities originally contemplated are so changed in a proposed Change Order, that application of the agreed unit prices to the quantities of Work proposed will cause substantial inequity to the Owner, the Contractor or the Subcontractor, the applicable unit prices shall be equitably adjusted.

13.2 **CONCEALED CONDITIONS**

13.2.1 Should concealed conditions encountered in the performance of the Work below the surface of the ground or should concealed or unknown conditions in an existing structure be at variance with the conditions indicated by the Contract Documents, or should unknown physical conditions in an existing structure of an unusual nature, differing materially from those ordinarily encountered and generally recognized as inherent in Work of the character provided for in this Contract be encountered, the Contractor shall report the conditions to the Designated Representative before the conditions are disturbed. The Designated Representative shall thereupon notify the Architect/Engineer. Upon such notices, or upon its own observation of such conditions, the Architect/Engineer shall promptly make such changes in the Contract Documents as he finds necessary to conform to the different conditions. Any change in the cost of the Work or the time needed for completion resulting from concealed conditions shall be determined in accordance with Paragraph 13.1 provided a notice thereof is made within ten (10) days after the first observance of the conditions.

13.3 **CLAIMS FOR ADDITIONAL COST**

13.3.1 If the Contractor claims that any instructions given to him by the Owner or Designated Representative or by the Architect/Engineer, by drawings or otherwise, involve extra Work not covered by the Contract, he shall give the Designated Representative written notice thereof within ten (10) days after the receipt of such instructions and before proceeding to execute the Work, except in emergencies endangering life or property, in which case the Contractor shall proceed in accordance with Paragraph 11.3. Should it not be clear to the Contractor that a change will involve extra Work, written notice given within ten (10) days that the change may involve extra work will be considered sufficient notice. If it is later determined that the Work involved in such instruction shall be recognized as an extra, the amounts of additional compensation to be paid therefore, should be determined in accordance with Paragraph 13.1. Except as otherwise specifically provided, no claim for additional cost shall be allowed unless the notice specified by this Subparagraph is given by the Contractor or unless such Work is performed as provided in Subparagraph 13.1.4. Any change in the contract sum resulting from such claim shall be authorized by agreement amendment.

13.3.2 If the Contractor claims that additional cost is involved because of, but not limited to, (1) written interpretation issued pursuant to Subparagraph 3.2.2, (2) any order by the Owner or Designated Representative to stop the Work pursuant to Paragraph 4.3 where the Contractor was not at fault, or (3) any written order for a minor change in the Work issued pursuant to Paragraph 13.4, the Contractor shall make such claims as provided in Subparagraph 13.3.1.

13.3.2.1 Any claim for damages of any character, delays for which the Owner is liable under the Contract Documents, extra work or extra compensation of any other nature, shall be waived unless notice thereof is given to the Owner, in writing, within ten (10) days after the initial occurrence of the first event, which is relied upon to justify the claim or within such time as the event should have reasonably been discovered by the Contractor and in any event, before extra cost is incurred.

13.3.2.2 Any claim for a delay for which the Owner is liable will not be allowed where there is a concurrent delay that is the responsibility of the Contractor.

13.3.2.3 No claim for damages of any character due to delays caused by adverse weather, acts of God, strikes, fire or unavoidable casualties will be allowed. The Contractor shall bear the expenses related to additional time granted for "force majeure" events.

13.3.2.4 The written notice of potential claim shall set forth the reasons for which the Contractor believes additional compensation will or may be due, the nature of the costs involved, and, insofar as possible, the amount of the potential claim. The said notice as above required must have been given to the Designated Representative prior to the time that the Contractor shall have performed the work giving rise to the potential claim for additional compensation, if based on an act or failure to act by the Designated Representative, or in all other cases within ten (10) days after the happening of the event, thing or occurrence giving rise to the potential claim. It is the intention of this paragraph that differences between the parties arising under and by virtue of the contract be brought to the attention of the Designated Representative at the earliest possible time in order that such matters may be settled, if possible, or other appropriate action promptly taken. The Contractor hereby agrees that he shall have no right to additional compensation for any claim that may be based on any such act, failure to act, event, thing or occurrence for which no written notice of potential claim as herein required was filed.

13.4 **MINOR CHANGES IN THE WORK**

13.4.1 The Architect/Engineer will have the authority to order, through the Designated Representative, minor changes in the Work not involving an adjustment in the Contract Sum or an extension of the Contract Time and not inconsistent with the intent of the Contract Documents. Such changes will be affected by written order and such changes shall be binding on the Owner, the Designated Representative and the Contractor. The Contractor shall carry out such written orders promptly.

ARTICLE 14: UNCOVERING AND CORRECTION OF WORK

14.1 UNCOVERING OF WORK

14.1.1 If any portion of the Work should be covered contrary to the request of the Owner through the Designated Representative or Architect/Engineer, or to requirements specifically expressed in the Contract Documents, it shall, if required in writing by the Designated Representative, be uncovered for their observation and replaced, at the Contractor's expense.

14.1.2 If any other portion of the Work has been covered which neither the Designated Representative nor the Architect/Engineer has specifically requested to observe prior to being covered, the Architect/Engineer or Designated Representative, with written approval of the Owner, may request to see such work and it shall be uncovered by the Contractor. If such work is found in accordance with the Contract, the cost of uncovering and replacement shall, by an appropriate Change Order, be charged to the Owner, as the case may be. If such Work is found not in accordance with the Contract Documents, the Contractor shall pay such costs unless it is found that this condition was caused by a separate contractor employed as provided in Article 7 and in that event, the separate contractor shall be responsible for payment of such costs.

14.2 CORRECTION OF WORK

14.2.1 The Contractor shall promptly correct all Work rejected by the Architect/Engineer or the Designated Representative as defective or as failing to conform to the Contract Documents whether observed before or after Substantial Completion and whether or not fabricated, installed or completed. The Contractor shall bear all costs of correcting such rejected Work, including compensation for the Architect/Engineer's and Designated Representative's additional services made necessary thereby.

14.2.2 Notwithstanding acceptance of the Work by the Owner, if any of the Work is found to be defective or not in accordance with the Contract Documents, the Contractor shall correct it promptly after receipt of written notice from the Designated Representative to do so, unless the Owner has previously given the Contractor a written acceptance of such condition. This obligation shall survive the termination of the Contract. The Designated Representative shall give such notice promptly after discovery of the condition.

14.2.2.1 If, within one (1) year after the Date of Substantial Completion of the Work or the designated portion thereof, or within one (1) year after acceptance by the Owner of designated equipment or within such longer period of time as may be prescribed by law or by the terms of any applicable special warranty required by the Contract Documents, the Contractor shall correct it promptly after receipt of written notice from the Owner or Designated Representative to do so unless the Owner or the Designated Representative has previously given the Contractor written acceptance of such condition. This obligation shall survive the termination of the Contract. The Owner or Designated Representative shall give such notice promptly after discovery of the condition.

14.2.3 The Contractor shall remove from the site all portions of the Work which are defective or nonconforming and which have not been corrected under Subparagraph 5.5.1, 14.2.1 and 14.2.2 unless removal has been waived by the Owner.

14.2.4 If the Contractor fails to correct the defective or nonconforming Work as provided in Subparagraph 5.5.1, 14.2.1 and 14.2.2, the Owner may correct it in accordance with Subparagraph 4.3.2.

14.2.5 If the Contractor does not proceed with the correction of such defective or nonconforming Work within a reasonable time fixed by written notice from the Designated Representative, the Owner may remove it and may store the materials or equipment at the expense of the Contractor. If the Contractor does not pay the cost of such removal and storage within ten (10) days thereafter, the Owner may, upon ten (10) additional days written notice, sell such Work at auction or at private sale and shall account for the net proceeds thereof, after deducting all costs that should have been borne by the Contractor, including compensation for the Designated Representative's additional services made necessary thereby. If such proceeds of sale do not cover all costs, which the Contractor should have borne, the difference shall be charged to the Contractor and the appropriate Change Order shall be issued. If the payments then or thereafter due the Contractor are not sufficient to cover such amount, the Contractor shall pay the difference to the Owner.

14.2.6 The Contractor shall bear the cost of making good all Work of the Owner or other contractors destroyed or damaged by such removal or correction.

14.2.7 Nothing contained in this Paragraph 14.2 shall be construed to establish a period of limitation with respect to any other obligation which the Contractor might have under the Contract Documents, including Paragraph 5.5 hereof. The establishment of the time period of one (1) year after the Date of Substantial Completion or such longer period of time as may be prescribed by law or by the terms of any warranty required by the Contract Documents, relates only to the specific obligation of the Contractor to correct the Work and has no relationship to the time within which its obligation to comply with the Contract Documents may be sought to be enforced, nor to the time within which proceedings may be commenced to establish the Contractor's liability with respect to its obligations other than specifically to correct the Work.

14.3 ACCEPTANCE OF DEFECTIVE OR NONCONFORMING WORK

- 14.3.1 If the Owner prefers to accept defective or nonconforming Work, he may do so instead of requiring its removal and correction, in which case a Change Order will be issued to reflect reduction in the Contract Sum where appropriate and equitable. Such adjustment shall be affected whether or not Final Payment has been made.

ARTICLE 15: TERMINATION OF THE CONTRACT

15.1 TERMINATION BY THE CONTRACTOR

- 15.1.1 If the Work is stopped under an order of any court or other public authority having jurisdiction for a period of three (3) months, through no fault of the Contractor or a Subcontractor or their agents or employees or any other person performing any of the Work under a contract with the Contractor, or if the Designated Representative should arbitrarily fail to issue any certificate for payment within a reasonable time after it is due, or if the Owner should fail to pay within sixty (60) days, any sum certified by the Designated Representative to the Contractor, he may, upon thirty (30) additional days written notice by the Contractor, stop Work or terminate the Contract and recover from the Owner payment for all Work executed and for any proven loss sustained upon any materials, equipment, tools, construction equipment and machinery.

15.2 TERMINATION BY THE OWNER

- 15.2.1 If the Contractor is adjudged bankrupt or if he makes a general assignment for the benefit of its creditors or if a receiver is appointed on account of its insolvency, or if he persistently or repeatedly refuses or fails, except in cases for which extension of time is provided, to supply enough properly skilled workmen or proper materials, or if he fails to make prompt payment to Subcontractors or for materials or labor, or persistently disregards laws, ordinances, rules regulations, orders of any public authority having jurisdiction, or otherwise is guilty of a substantial violation of a provision of the Contract Documents, then the Owner may, without prejudice to any right or remedy and after giving the Contractor and its surety, ten (10) days written notice, terminate the employment of the Contractor and take possession of the site and of all materials, equipment, tools, construction equipment and machinery thereon owned by the Contractor and may finish the Work by whatever method he may deem expedient. In such case the Contractor shall not be entitled to receive any further payment until the Work is finished.
- 15.2.1.1 If the unpaid balance of the Contract Sum exceeds the costs of finishing the Work, including compensation for the Designated Representative's additional services made necessary thereby, such excess shall be paid to the Contractor. If such costs exceed the unpaid balance, the Contractor shall pay the difference to the Owner.
- 15.2.1.2 The expenses incurred by the Owner or Designated Representative and the damage incurred through the Contractor's default shall be certified by the Architect/Engineer.
- 15.2.2 The Owner may terminate the contract at its own discretion or when conditions encountered during the work make it impossible or impracticable to proceed, or when the Owner is prevented from proceeding with the contract by act of God, by law, or by official action of a public authority.
- 15.2.3 After receipt of a Notice of Termination, the Contractor shall submit to the Owner through the Designated Representative its written termination claims in the form and with the certification which the Owner or Designated Representative may require. Such claims shall be submitted promptly, but in no event more than thirty (30) days after the effective date of termination.

ARTICLE 16: PROJECT REQUIREMENTS

16.1 PROJECT REPORTS

- 16.1.1 Contractor Reports: Immediately after the contract is awarded, a meeting will be scheduled at the project site to review project procedures, designation of name and title of the authorized person or persons, representing the Contractor and responsible for the project management and field operation, designation of Emergency Contact, designation of representative for progress meetings, the requirements for daily, weekly and monthly reports and other submittals required to perform and administer the project. Without limiting the reports required, several reports are indicated below with their requirements:
- 16.1.2 Daily Force and Activity Reports: The Contractor shall prepare and submit to the Designated Representative, including similar data for each of its Subcontractors, a Daily Force and Activity Report. This report shall be on a form approved by the Designated Representative and shall indicate all Supervisors, Journeymen, Laborers or Helpers and, by crew, the activities, related to the Contractor's schedule, that are being performed. The Daily Force and Activity Report shall include information on material deliveries, tests, weather conditions and other significant events. Each Daily Force and Activity Report shall be delivered to the Designated Representative at the job site by 9:00 a.m. on the next succeeding businessday.
- 16.1.3 Daily Change Documentation: The Contractor shall submit to the Designated Representative for review and verification, separate daily documentation of any "Change in the Work" being performed on any basis, other than agreed upon lump sum, as described in Article 13 of the General Conditions. This report shall be on a form approved by the Designated Representative. The Contractor shall certify the accuracy of this report.
- 16.1.4 Safety Reports: The Contractor shall submit to the Designated Representative copies of all accident reports and weekly minutes/reports of Safety Program "Tool Box" meeting and other safety information.

- 16.1.5 Material Status Reports: The Contractor shall prepare a Materials Status Report not later than fifteen (15) calendar days after the Notice to Proceed. The report shall include a complete list of suppliers, items to be purchased from them, the fabricator and manufacturer, the time required and the promised delivery dates for each item. This report shall be updated and submitted with the payment requisition monthly as an integral part thereof and more frequently as requested by the Designated Representative.
- 16.1.6 Purchase Orders: A copy of each purchase order as issued by the Contractor shall be furnished to the Designated Representative, except that prices may be omitted.
- 16.1.7 Job Cost Breakdown: The Contractor shall submit job cost breakdown reports for record and tax purposes to the Designated Representative. The first report shall be submitted within thirty (30) calendar days after date of each Notice to Proceed on any portion of the Work and shall be consistent in format with the schedule of values. Another report shall be submitted at the completion of the job and shall include all additions and deletions. Interim reports on various elements of the Work shall be submitted as required by the Owner for investment, tax credit, pollution control, financing and other purposes.
- 16.1.8 Monthly Progress Payment Applications: The Contractor shall submit Monthly Progress Payment Applications in the form and at the time as approved by the Designated Representative.
- 16.1.9 Monthly Reports: The Contractor shall submit to the Designated Representative copies of all monthly reports, such as MBE Participation, etc., required by governing bodies.
- 16.1.10 Monthly Certification: The Contractor shall submit to the Designated Representative periodic evidence and a monthly certification that "Record Documents", Test Reports and other Project Record Documents are being maintained for ultimate submittal to the Designated Representative and Owner at the completion of the Work.
- 16.1.11 Weekly Request for Information Status: The Contractor shall submit, each week on a day agreed to between the Contractor and the Designated Representative, a Request for Information Status Report indicating the Contractor's perception of the status of all submitted Requests for Information. The Request for Information Status Report will include a brief description of the request, date the request was submitted to the Designated Representative, date a response is needed from the Architect/Engineer, date a response is actually made by the Architect/Engineer, and any pertinent remarks. The Request for Information Status Report shall be in a format approved by the Designated Representative.

16.2 DRAWINGS, PRODUCT DATA AND SAMPLES

- 16.2.1 Shop Drawings: Shop drawings are drawings, diagrams, schedules and other data especially prepared for the Work by the Contractor, Subcontractor, Sub-subcontractor, manufacturer, supplier or distributor to illustrate some portion of the Work. Shop drawings shall be signed by a registered professional engineer where required by law.
- 16.2.2 Product Data: Product data are illustrations, standard schedules, performance charts, instructions, brochures, diagrams and other information furnished by the Contractor to illustrate a material, product, equipment or system for some portion of the Work.
- 16.2.3 Samples: Samples are physical examples which illustrate materials, equipment or workmanship and establish standards by which the Work will be judged.
- 16.2.4 Submittals: Submittals forwarded by the Contractor to the Designated Representative shall be in conformance with the requirements of the Contract Documents. The Contractor shall notify the Architect/Engineer and Designated Representative in writing of any deviations in the submittals from the requirements of the Contract Documents at the time of submission. Before submission of each Shop Drawing, Product Data or Sample, the Contractor shall have determined and verified all quantities, dimensions, specified design and performance criteria, installation requirements, materials, catalog numbers and similar data with respect thereto and review or coordinated each Shop Drawing, Product Data or Sample with other Shop Drawings, Product Data and Samples and with the requirements of the Work and the Contract Documents. The term "submittal" as used herein includes Shop Drawings, Product Data and/or Samples as required by the Contract Documents. All submittals shall be submitted thirty (30) days prior to commencement of work affected.
- 16.2.5 Notice of Variation: At the time of each submission, the Contractor shall give the Architect/Engineer specific written notice of each Contractor perceived variation that the submittal may have from the requirements of the Contract Documents and, in addition, the Contractor shall cause a specific notation to be made on each Shop Drawing, Product Data and/or Sample submitted to the Architect/Engineer for review and "approval" demonstrating each such perceived variation.
- 16.2.6 Architect/Engineer Submittal Review: The Architect/Engineer will review and "approve" with reasonable promptness the required submittals. The Architect/Engineer's review and approval of the Contractor's submittal does not constitute a complete check, but indicates only that design, general method of construction and detailing is satisfactory. The Architect/Engineer's review and approval does not permit any deviation from the Contract Requirements and does not relieve the Contractor of the responsibility for errors in dimensions, details, sizes of member, etc., or the coordinating of installation and construction with actual conditions of the Work. The Architect/Engineer's review and "approval" will be only for conformance with the design concept of the Project and

for compliance with the information given in the Contract Documents and shall not extend to means, methods, techniques, sequences or procedures of construction (except where a specific means, the methods, technique sequence or procedure of construction is indicated in or required by the Contract Documents) or to safety precautions or safety programs incident thereto. The individual review and "approval" of a component item as such will not indicate "approval" of the integrated final assembly into which the item is placed and in which the item must function. The Contractor shall make any corrections required by the Architect/Engineer, without any additional cost to the Owner. The Contractor shall return the required number of corrected copies of submittals to the Architect/Engineer who will promptly, as required, review the re-submittals for conformance with the design concept.

16.2.7 Resubmission Notice: The Contractor shall direct specific attention, in writing or on resubmitted Shop Drawings, Product Data or Samples, to all revisions other than those requested by the Architect/Engineer or Designated Representative on previous submittals.

16.2.8 Contractor Responsibility: Review and "approval" of submittals by the Architect/Engineer shall not relieve the Contractor from responsibility for any variation from the requirements of the Contract Documents unless the Contractor has in writing called the Architect/Engineer's attention to each such variation at the time of submission as required and the Architect/Engineer has given written approval of each such variation by a specific written notation thereof incorporated in or accompanying the submittal "approval"; nor will any "approval" by the Architect/Engineer relieve the Contractor from the responsibility for the Contractor's own errors or omissions in the submittal or from the Contractor's responsibility for compliance with all Contract Document provisions.

16.2.9 No Work Prior to Submittal Approval: The Contractor shall resubmit submittals as required until the Architect/Engineer's approval is obtained. No work requiring submittals shall be executed until the Architect/Engineer's approval is given. Where a submittal is required by the Specifications, any related work performed prior to the Architect/Engineer's review and "approval" of the pertinent submission will be at the sole risk, expense and responsibility of the Contractor.

16.2.10 Transmittal Requirements: After checking and verifying all field measurements and complying with applicable procedures specified in the Contract Documents, the Contractor shall transmit all submittals to the Architect/Engineer with one (1) copy to the Designated Representative and shall include:

- (a.) Date and revision dates.
- (b.) Project title and number.
- (c.) The names of:
 - (1.) Architect/Engineer
 - (2.) Designated Representative
 - (3.) Contractor
 - (4.) Contract Number
 - (5.) Subcontractor or Supplier
 - (6.) Manufacturer
 - (7.) Separate Detailer when pertinent
- (d.) Number of Shop Drawings, Product Data and Sample submitted. (System to be established by Designated Representative.)
- (e.) Identification of product or material.
- (f.) Relation to adjacent structure or materials. (g.) Field dimensions, clearly identified as such. (h.) Specification section number and paragraph.
- (i.) Applicable standards such as ASTM number or Federal Specification.
- (j.) A blank space, minimum of 2 1/2 by 3 1/2 inches for the Architect/Engineer stamp. (k.) Identification of deviations from Contract Documents.
- (l.) Other pertinent data.

16.2.11 Approval Delays: The Contractor shall be responsible for any delays caused by the rejection of the submittal for inadequate or incorrect shop drawings, manufacturer's data or other information.

16.2.12 Working Drawings: The Contractor is responsible for seeing that only "Approved" copies of shop drawings bearing the stamp of the Architect/Engineer are allowed on the job.

16.2.13 Approved Equals: The Contractor's attention is directed to Article 5.4 LABOR AND MATERIALS. Where two or more products are specified for an item of Work, either one thereof is acceptable and the choice is left to the Contractor. Where only one product is specified and where the term "or approved equal" or similar wording is used in connection with specified products, the Contractor may, if he so desires, offer for consideration a substitute product which he judges to be equal in every respect to the required product. When a specific process is specified as well as a guarantee of the results, the Contractor shall, if in its judgement the process may not produce the required result, submit for approval, an alternative process which he would guarantee. All such submittals shall be made, within forty (40) calendar days after award of the Contract, in writing to the Designated Representative, who in turn will forward them to the Architect/Engineer. Review of any substitute product will (1) be contingent upon submission of substantiating serviceability to specified product; (2) use of the item will not entail changes in details and construction of related Work; (3) item conforms to required design and artistic effect. The Contractor shall furnish with the first submittal, a sufficient number of drawings, specifications, samples, performance data and other information necessary to assist the Architect/Engineer in determining whether the proposed substitution is

acceptable. The burden of proof shall be upon the Contractor. No consideration will be given to incomplete submittals. Substitutions shall be approved in writing before they may be used.

- 16.2.14 Conflicting Instructions: When product manufacturer's instructions are in conflict with the Contract Documents, the Contractor shall notify the Designated Representative for clarification before proceeding. The Contractor shall keep a copy of the various product manufacturer's instructions applicable to the Work at the project site.
- 16.2.15 Submittal Log: Each week on a day agreed to between the Contractor and the Designated Representative, the Contractor shall submit an updated submittal log to the Designated Representative indicating the Contractor's perception of the status of all required submittals and reviews. Similar information to that outlined below shall be provided for any required re-submittals. The submittal log will include such information as:
- (a.) The schedule date to receive information from a subcontractor or supplier.
 - (b.) The actual date information was received from a subcontractor or supplier.
 - (c.) The scheduled date to submit information to the Architect/Engineer.
 - (d.) The date information was submitted to Architect/Engineer.
 - (e.) Anticipated date of return of information from Architect/Engineer.
 - (f.) Actual date information was received from Architect/Engineer.
 - (g.) Status or actions required.
- 16.2.16 Sample Submission: The Contractor shall submit all required samples for review and "approval" by the Architect/Engineer, with such promptness as to cause no delay in the Work. All samples shall be checked by the Contractor and accompanied by a specific written indication that the Contractor has satisfied Contractor's responsibilities under the Contract Documents with respect to the Contractor's review of the submission. The samples shall be identified clearly as to equipment, material, supplies and include pertinent data such as demonstrating compliance with a certain Specification Section, catalog number, etc., and the use for which the material is intended. An approved sample of each material shall be provided to the Designated Representative prior to delivery of any materials for which submission of samples is required.
- 16.2.17 Sample Review: The Contractor shall submit four (4) samples of materials to the Architect/Engineer for approval as indicated in the Specifications. All samples shall be properly labeled to indicate type of material submitted, intended use, manufacturer's name, trade name, project name, Designated Representative's name, Contractor's, Subcontractor's and Supplier's names; and shall be transmitted as required by paragraph 16.2.10. Samples will be inspected and tested as required and if acceptable an approved notice will be sent to the Contractor along with one (1) approved sample. Rejected samples will be returned along with a statement of reasons for rejection. Accepted samples will be retained by the Architect/Engineer, one of which will be provided to the Designated Representative and shall become the property of the Owner.
- 16.2.18 Submittals Affecting the Contract Sum: The Architect/Engineers approval of submittals which deviate from the Contract Documents does not authorize changes to the Contract Sum. The Contractor shall notify the Architect/Engineer and the Designated Representative in writing at the time of transmittal of any changes to the Contract Sum affected by such approval of a submittal; otherwise, claim for extras will not be considered.
- 16.2.19 Ductwork Layout Drawings: As soon as practical and in no case starting later than thirty (30) days after the award of contract, the Mechanical Subcontractor shall prepare layout drawings of all duct work and piping at not less than 3/8" scale. The ductwork layout drawings shall show registers, grilles, diffusers and similar features as well as locations of all valves, dampers and other items requiring access for service and maintenance. The ductwork layout drawings shall also show beams, ceiling heights, walls, floor to floor dimensions, columns, doors and other major architectural and structural features as shown on the architectural and structural drawings.
- 16.2.20 Coordination with Subcontractors: The Contractor shall, within sixty (60) days after award, send a reproducible and two (2) prints of the ductwork layout drawings to the plumbing, materials handling, fire protection and electrical subcontractors who shall then make on the reproducible their own routings as well as other major items such as valves, access panels, switch panels, etc., as required to determine interrelationship and possible interferences with the mechanical ductwork and architectural or structural features. The marked-up reproducible shall then be returned to the Mechanical Subcontractor through the Contractor with copies to the Designated Representative no less than thirty (30) days after receipt by the other Subcontractors.
- 16.2.21 Composite Drawings: The Mechanical Subcontractor shall prepare preliminary composite drawings of such layout drawings, incorporating all the information and routings provided by the other Subcontractors. (At its option, a group of transparent overlays may be substituted, provided that they clearly show the relationship of all proposed installations.) The preliminary composite drawings, or the overlays, shall be reviewed during a series of meetings, called by the Contractor and attended by the Architect/Engineer and the Designated Representative, at which all Subcontractors and trades shall be represented, in order to review and resolve any real or apparent interferences or conflicts.
- 16.2.22 Agreement by Subcontractors: After all conflicts or interferences are resolved the Mechanical Subcontractor shall develop a final set of composite drawings showing the agreed upon routing, layout and juxtaposition of all ductwork, conveyers, piping, major conduit, valves, panels, lighting fixtures and all other major mechanical and electrical installations. In areas where no mechanical ductwork occurs, but where other mechanical and electrical installations are installed, each Subcontractor shall be responsible for its own Work and shall cooperate in preparing similar composite drawings, shall perform its own drafting Work and pay its own costs in connection therewith. In

preparation of all the final composite drawings, large scale details as well as cross and longitudinal sections shall be as required to fully delineate all conditions. Particular attention shall be given to the locations, size and clearance dimensions of equipment items, shafts and similar features. These final composite drawings shall then be signed-off by each of the Subcontractors, including the Mechanical Subcontractor, and the Contractor indicating their awareness of an agreement with the indicated routings and layouts and their interrelationship with the adjoining or contiguous Work. Thereafter, no unauthorized deviations will be permitted and if made without knowledge or agreement of the Architect/Engineer and Designated Representative, this unauthorized Work will be subject to removal and correction at no additional cost to Owner.

- 16.2.23 Minor Changes: In preparing the composite drawings, minor changes in duct, pipe or conduit routings that do not affect the intended function may be made as required to avoid space conflicts, when mutually agreed, but items may not be resized or exposed items relocated without the Architect/Engineers and Designated Representative's written approval. No changes shall be made in any wall or chase locations, ceiling heights, door swings or locations, window or other openings or other features affecting the function or aesthetic effect of the building. If conflicts or interferences cannot be satisfactorily resolved, the Architect/Engineer and the Designated Representative shall be notified and their decision obtained.
- 16.2.24 Distribution of Composite Drawings: After the final composite drawings have been agreed upon and signed by all Subcontractors, the Contractor shall provide and distribute four (4) prints to each of the Subcontractors, to the Architect/Engineer and to the Designated Representative for reference and record purposes. The Contractor shall make similar distribution of all supplementary composite drawings, initiated by other Subcontractors as indicated herein before. All Subcontractors desiring additional prints of such drawings, beyond the basic distribution indicated above, shall arrange for and pay the cost of the same.
- 16.2.25 Record Composite Drawings: The record copies of the final composite drawings shall be retained by the Designated Representative and each Contractor as a working reference. All shop drawings, prior to their submittal to the Architect/Engineer, shall be compared with the composite drawings and developed accordingly by the Contractor and the responsible Subcontractor. Any revision to the composite drawings which may become necessary during the progress of the Work shall be noted by the Contractor and all Subcontractors and shall be neatly and accurately recorded on the record copies. The Contractor and each Subcontractor shall be responsible for the up-to-date maintenance of its record copies of the composite drawings and to keep two (2) copies available at the site. The composite drawings and any subsequent changes thereto, shall be utilized by the Contractor and each Subcontractor in the development of its "Record Document" drawings.
- 16.2.26 Timely Submissions: The composite drawings need not be submitted as a whole, but they shall be submitted in all cases in ample time to avoid construction delay. The coordination drawings may lack complete data in certain instances pending receipt of shop drawings, but sufficient space shall be allotted for the items affected. When final information is received, such data shall be promptly inserted on the compositedrawings.
- 16.2.27 Improperly Coordinated Work: No extra compensation will be paid for relocating any duct, pipe, conduit, or other material that has been installed without proper coordination between the Contractor and all Subcontractors involved. If any improperly coordinated Work or Work installed that is not in accordance with the approved composite drawings, necessitates additional Work by the Contractor or other Subcontractors, the costs of all such additional Work shall be borne solely by the Contractor or the Subcontractor responsible for the nonconforming Work.
- 16.2.28 Incorporation of Changes: All changes in the scope of Work due to revisions formally issued and approved shall be shown on the composite drawings.
- 16.2.29 Quality Draftsmanship: All Work on shop drawings, ductwork layout drawings, coordination drawings, and composite drawings shall be performed by competent draftsmen and shall be clear and fully legible. The Architect/Engineer shall be the sole judge of the acceptability of the drawings.
- 16.2.30 Structural Cutting: The Contractor shall obtain specific positive written instructions from the Architect/Engineer through the Designated Representative before cutting beams or other structural members, arches or lintels, and the Contractor shall be guided by such instructions.

16.3 TEMPORARY SERVICES, SYSTEMS AND FACILITIES

- 16.3.1 Temporary Lighting, Power and Water: At its own expense, the Contractor shall furnish, install, maintain, and remove all temporary lighting, electric power, and potable water, including piping, wiring, lamps, and other equipment necessary for the execution and security of the Work; and shall be responsible for the cost of power and water usage. The Contractor shall not draw water from any fire hydrant, except to extinguish a fire, without first obtaining permission from the water agency concerned. The Contractor shall provide for distribution of drinking water to all work forces under this Contract.
- 16.3.2 Sanitation: The Contractor shall provide and maintain portable enclosed toilets for the use of all work forces under this Contract. These accommodations shall be maintained in a neat and sanitary condition. They shall also comply with all applicable laws, ordinances and regulations pertaining to the public health and sanitation of dwellings and camps. The Contractor shall not interrupt the flow of existing sanitary sewers. Should the Work involve the disruption of existing sewer facilities, the Contractor shall convey the sewage in closed containers and shall dispose of it in a sanitary sewer system as approved by local health authorities and the Designated Representative. Sewage shall not be permitted to flow in trenches or be covered by backfill.

- 16.3.3 Vermin Control: The Contractor shall maintain the job site free of rodents, insects, vermin and pests throughout all phases of construction, including suspensions of work, and until final acceptance of the Work. Necessary extermination work shall be arranged and paid for by the Contractor as part of the contract work and contract time and shall be performed by a licensed agency in accordance with requirements of governing authorities. The Contractor shall be liable for injury to persons or property and responsible for the elimination of offensive odors resulting from extermination operations.
- 16.3.4 Water Pollution Control: The Contractor shall exercise every reasonable precaution to protect channels, storm drains, and bodies of water from pollution and shall conduct and schedule its operations so as to minimize or avoid muddying and silting of said channels, drains, and waters. Water pollution control work shall consist of constructing those facilities which may be required to provide prevention, control, and abatement of water pollution.
- 16.3.5 Air Pollution Control: The Contractor shall not discharge smoke, dust, or any other air contaminants into the atmosphere in such quantity as will violate the regulations of any legally constituted authority.
- 16.3.6 Project Site Maintenance: Throughout all phases of construction, including suspensions of work, and until final acceptance of the Work, the Contractor shall keep the job site, including the interior of all structures, clean and free from rubbish and debris. The Contractor shall provide and maintain rubbish containers and periodic rubbish removal services as required by the pace of the Work and health regulations, and as acceptable to the Designated Representative.
- 16.3.6.1 The Contractor shall abate dust nuisance by cleaning, sweeping, and sprinkling with water, or other means as necessary. The use of water resulting in mud on public streets will not be permitted as a substitute for sweeping or other methods.
- 16.3.6.2 Materials and equipment shall be removed from the site as soon as they are no longer necessary; and upon completion of the Work and before final inspection the entire work site shall be cleared of equipment, unused materials, and rubbish so as to present a satisfactory clean and neat appearance. All cleanup costs shall be absorbed in the Contractor's bid.
- 16.3.6.3 The Contractor shall take care to avoid spillage on haul routes. Any such spillage shall be removed immediately and the area cleaned by the Contractor.
- 16.3.6.4 Burning or burying of rubbish and waste materials on the project site is prohibited. Disposal of volatile fluid wastes in storm and sanitary sewer systems is prohibited.
- 16.3.6.5 Waste materials shall not be dropped or thrown from heights. Cleaning operations shall be scheduled so that dust and other contaminants resulting from the cleaning process will not fall on wet or newly painted surfaces. Dusty debris shall be sprinkled lightly with water as required to control dust.
- 16.3.6.6 The Contractor shall vacuum clean the interior of buildings prior to the start of finish painting. The Contractor shall continue vacuum cleaning thereafter on an as needed basis until the building is ready for acceptance.
- 16.3.6.7 Failure of the Contractor to comply with the Designated Representative's cleanup orders may result in an order to suspend the Work until the condition is corrected. No additional compensation will be allowed as a result of such suspension.
- 16.3.7 Final Cleaning: At the completion of the Work, the Contractor at its sole expense shall remove all waste materials and rubbish from and about the project, as well as all tools, construction equipment, temporary facilities, machinery, and surplus materials.
- 16.3.7.1 At completion of construction and just prior to final inspection, the Contractor shall thoroughly clean the interior and exterior of the buildings, including hardware, floors, roofs, sills, ledges, glass, or other surfaces where debris, plaster, paint, spots, and dirt or dust may have collected. All glass shall be washed clean and polished. All grease, stains, labels, fingerprints, and other foreign materials shall be removed from interior and exterior surfaces. The Contractor shall repair, patch, and touch up marred surfaces to match adjacent finishes.
- 16.3.7.2 The Contractor shall use only experienced workmen or professional cleaners for final cleaning. Use only cleaning materials recommended by the manufacturer of the surface to be cleaned, and use cleaning materials only on surfaces recommended by the cleaning material manufacturer.
- 16.3.7.3 The Contractor shall broom clean all paved surfaces and rake clean other surfaces of grounds.
- 16.3.7.4 The Contractor shall replace air conditioning filters, if units were operated during construction. The Contractor shall clean all ducts, blowers, and coils if air conditioning units were operated at any time without filters during construction.
- 16.3.7.5 The Contractor shall maintain the building in a clean condition until it is accepted by the Owner.
- 16.3.8 Fire Protection: The Contractor at its sole expense shall provide temporary fire safety equipment for general use. The Contractor shall provide fire extinguishers for its trailers, for use as required when cutting and burning is

performed, and as required throughout the job site as instructed by the local fire marshal.

- 16.3.9 Communication Systems: The Contractor shall provide telephone services at its own expense. The Contractor at its sole expense shall maintain in service a facsimile telecopy machine whenever telephone service is available at the job site. The use of portable radios shall be in accordance with Federal Regulations and shall not interfere with other local radio operations.
- 16.3.10 Office Facilities: The Contractor at its sole expense shall provide, maintain and remove temporary field office facilities, including all furniture, equipment, copiers, heating, cooling, lighting, power, telephones, drinking water, plumbing and toilet fixtures as necessary for its performance of the Work; and shall make these spaces, telephones, and services available for the use of the Owner, the Designated Representative and the Architect/Engineer. A designated work area shall be provided for the use of the Owner, the Designated Representative and the Architect/Engineer.
- 16.3.11 Weather Protection: The Contractor at its sole expense shall be responsible for providing protection for its own Work against inclement weather, in order to maintain all Work, materials, apparatus, and equipment. All Work subject to damage by adverse weather conditions shall be covered or otherwise protected as required. Weather protection shall be adequate to permit the Contractor to Work on a continuous basis without shutdown due to temperature or weather conditions as far as possible.
- 16.3.12 Dewatering: The Contractor at its sole expense shall provide all temporary drainage and dewatering measures including all pumping, drainage, erosion control or other work required to protect the Work while in progress.
- 16.3.12.1 Inundation of partially completed work due to lack of control during non-working periods will not be permitted, and may be cause for requiring removal of work already completed with replacement at the Contractor's expense.
- 16.3.12.2 The Contractor shall be responsible for obtaining the use of any property, in addition to that provided for in the plans and specifications, which may be required for the diversion and protective works so as not to create a hazard to persons or property or to interfere with the water rights of others.
- 16.3.12.3 It shall be understood and agreed that the Contractor shall hold the Owner and the Designated Representative harmless from legal action taken by any third party with respect to construction and operation of the diversion and protective works.
- 16.3.12.4 All works installed by the Contractor in connection with dewatering, control, and diversion of water but not specified to become a permanent part of the project, shall be removed and the site restored, insofar as practical, to its original condition prior to completion of construction or when directed by the Designated Representative.
- 16.3.13 Material Handling: The Contractor at its sole expense shall be responsible for handling and transporting, including lifting, its material and equipment to the location of need in a timely manner.
- 16.3.14 Cranes, Hoists and Scaffolds: The Contractor at its sole expense shall furnish, erect, maintain and remove all cranes, temporary hoists and scaffolding as may be required by the Contractor for the performance of the Work.
- 16.3.15 Storage: The Contractor at its sole expense shall provide and remove whatever temporary storage facilities, sheds, buildings, enclosures, partitions, etc., he deems necessary for the protection of its materials, tools and equipment after receiving approval from the Designated Representative on specific details of the method proposed. Any damage caused to Work in place by these temporary measures will be repaired / replaced at the Contractor's expense.
- 16.3.16 Security Fences: The Contractor at its sole expense shall provide temporary site enclosures (fences), barriers, and pedestrian walkways as indicated by the Contract Documents or as required to control access to the job site.
- 16.3.17 Security Services: The Contractor at its sole expense shall be responsible for job site security during various phases of the Work, including non-working hours and at other times, and as may be required for the protection of the Owner and the Designated Representative's interests. All costs for same will be paid by the Contractor.
- 16.3.18 Openings, Sleeves and Supports: The Contractor at its sole expense shall provide all necessary openings, channels, chases, flues, sleeves, inserts, hangers, etc., if any, and such cutting, patching, finishing, etc., if any, required by the Contract Documents to complete the Work.
- 16.3.19 Protection and Restoration of Existing Improvements: The Contractor at its sole expense shall be responsible for the protection of public and private property adjacent to the Work and shall exercise due caution to avoid damage to such property. All costs to the Contractor for protecting, removing, and restoring existing improvements shall be paid by the Contractor.
- 16.3.19.1 The Contractor at its sole expense shall repair or replace all existing improvements which are damaged or removed as a result of its operations and which are not designated for removal (e.g. curbs, sidewalks, driveways, fences, walls, ceilings, floor coverings, signs, utility installations, pavements, structures, trees, shrubbery, grass etc.).
- 16.3.19.2 Repairs and replacements shall be at least equal to existing improvements and shall match them in finish and dimensions in such a manner that the repaired work will not be readily noticeable.

- 16.3.20 Excavation Protection: The Contractor at its sole expense shall provide and maintain fencing, shoring and bracing and dewatering of all excavation.
- 16.3.21 Temporary Safety Measures: The Contractor at its sole expense shall provide, maintain and remove when no longer required all temporary safety measures, including all construction supplies, barricades, pedestrian walkways and equipment as may be required by the Contract Documents for its Work.
- 16.3.22 Advertising: The names of the Contractor, Subcontractors, the Architect/Engineer, including their consultants, with their addresses and the designation of their particular specialties, may be displayed on removable signs. The size, format and location of such signs shall be subject to the Designated Representative's approval. Commercial advertising matter shall not be attached or painted on the surfaces of buildings, fences, canopies, or barricades. All signs shall be removed when directed by the Designated Representative but not later than final acceptance of the Work.

16.4 SAFETY

- 16.4.1 OSHA and California Codes and Regulations: The Contractor at its sole expense shall provide, erect, maintain, dismantle and remove any and all barricades, railings, covers, warning lights, safety netting, and similar safety devices required to complete its Work and protect the public in accordance with OSHA, California Administrative Code, Title 8 Industrial Relations, Chapter 4 Division of Industrial Safety, Section 4 Construction and Safety Orders, Article 8 Explosives, and all other applicable code requirements.
- 16.4.2 Traffic Control: The Contractor shall conduct its Work so as to interfere as little as possible with pedestrian and vehicular traffic and he shall, at its sole expense, provide and maintain proper warnings and detour signs at all pedestrian and vehicular closures, intersections and along detours, directing traffic around closed portions of roadways. He shall, at its own expense, wherever necessary or required, provide and maintain fences, temporary roadways, temporary crossing signs, watchmen, warning lights and take such other precautions as may be necessary to protect life and property and shall be responsible for all damages occasioned in any way by its act or neglect. All barricades and obstructions shall be illuminated at night and all lights shall be kept on from one-half hour before sunset until one-half hour after sunrise.
- 16.4.3 Fall Protection: When performing any cutting, removal, creating openings or holes, etc., the Contractor at its sole expense, by use of barricades, flagmen or other means, shall provide protective measures to assure that other workmen or the public are not exposed to potential injury by the operation being conducted.
- 16.4.4 Welding Protection: The Contractor at its sole expense shall provide, maintain and remove all shielding or similar precautions required to be taken adjacent to welding operations.
- 16.4.5 Personal Equipment: The Contractor at its sole expense shall provide and supervise the use of all proper safety and protective devices by its employees during any potentially dangerous phases of its Work.
- 16.4.6 Safety Orders: The Contractor shall have at the work site, copies or suitable extracts of: Construction Safety Orders, Electrical Safety Orders, and General Industrial Safety Orders issued by the State Division of Industrial Safety. The Contractor shall comply and shall require the compliance by all Subcontractors with provisions of these Safety Orders and all other applicable laws, ordinances, and regulations.
- 16.4.7 Trench Excavations: As required by Section 6705 of the California Labor Code and in addition thereto, whenever work under the Contract involves the excavation of any trench or trenches five (5) feet or more in depth, the Contractor shall submit for acceptance by the Owner, a detailed plan showing protection of the worker from the hazard of caving ground.
- 16.4.8 Use of Explosives: Explosives may be used only when authorized in writing by the Owner, or as otherwise stated in the Contract Documents. Explosives shall be handled, used, and stored in accordance with all applicable regulations. The Owner's approval of the use of explosives shall not relieve the Contractor from its liability for claims caused by its blasting operations.
- 16.4.9 Hazardous Materials: The Contractor shall immediately stop work if unforeseen suspected hazardous material conditions are encountered. The Contractor shall immediately report the unforeseen conditions in the written form of a request for information submitted to the Designated Representative. Work shall be resumed after the Owner has fully resolved the questions related to the unforeseen conditions and has remediated any hazardous materials determined to be present.

END OF GENERAL CONDITIONS

Exhibit "C"
Indemnification and Insurance Requirements (For
Construction Contracts

EXHIBIT C

Indemnification and Insurance Requirements (For Construction Contracts)

INDEMNIFICATION

CONTRACTOR agrees to indemnify, defend (with counsel reasonably approved by COUNTY) and hold harmless COUNTY and its officers, officials, employees, agents and volunteers from and against any and all claims, actions, losses, damages, judgments and/or liabilities arising out of this Agreement from any cause whatsoever, including the acts, errors or omissions of any person or entity and for any costs or expenses (including but not limited to attorneys' fees) incurred by COUNTY on account of any claim except where such indemnification is caused by the active negligence, sole negligence, or willful misconduct of the COUNTY.

NOTIFICATION OF ACCIDENTS AND SURVIVAL OF INDEMNIFICATION PROVISIONS

CONTRACTOR shall notify COUNTY immediately in the event of any accident or injury arising out of or in connection with this Agreement. The indemnification provisions in this Agreement shall survive any expiration or termination of this Agreement.

INSURANCE

CONTRACTOR shall procure and maintain for the duration of this Agreement insurance against claims for injuries to persons or damages to property which may arise from or in connection with the performance of the work hereunder and the results of that work by the CONTRACTOR, its agents, representatives, employees or subcontractors.

A. Minimum Scope and Limit of Insurance
Coverage shall be at least as broad as:

1. **Commercial General Liability (CGL):** Insurance Services Office (ISO) Form CG 00 01 covering CGL on an "occurrence" basis, including products-completed operations, personal & advertising injury, with limits no less than \$5,000,000 per occurrence and \$10,000,000 in the aggregate.
2. **Automobile Liability:** Insurance Services Office Form CA 0001 covering Code 1 (any auto), with limits no less than \$2,000,000 per accident for bodily injury and property damage.
3. **Workers' Compensation:** Insurance as required by the State of California, with Statutory Limits, and Employer's Liability Insurance with limit of no less than \$1,000,000 per accident for bodily injury or disease.
4. **Contractor's Pollution Legal Liability and/or Asbestos Legal Liability:** (if project involves environmental hazards) with limits no less than \$1,000,000 per occurrence or claim, and \$2,000,000 policy aggregate.

If the CONTRACTOR maintains higher limits than the minimums shown above, the COUNTY requires and shall be entitled to coverage for the higher limits maintained by the CONTRACTOR. Any available insurance proceeds in excess of the specified minimum limits of insurance and coverage shall be available to the COUNTY.

B. Other Insurance Provisions

The insurance policies are to contain, or be endorsed to contain, the following provisions:

1. **Additional Insured** – COUNTY, its officers, officials, employees, agents and volunteers are to be covered as additional insureds on the CGL policy with respect to liability arising

out of work or operations performed by or on behalf of the CONTRACTOR including materials, parts, or equipment furnished in connection with such work or operations. General liability coverage can be provided in the form of an endorsement to the CONTRACTOR'S insurance at least as broad as ISO Form CG 20 10 11 85 or **both** CG 20 10, CG 20 26, CG 20 33, or CG 20 38; **and** CG 20 37 forms if later revisions used).

2. **Primary Coverage** – For any claims related to this Agreement, the CONTRACTOR'S insurance coverage shall be primary insurance coverage at least as broad as ISO CG 20 01 04 13 as respects the COUNTY, its officers, officials, employees, agents and volunteers. Any insurance or self-insurance maintained by the COUNTY, its officers, officials, employees, agents or volunteers shall be excess of the CONTRACTOR'S insurance and shall not contribute with it.
3. **Notice of Cancellation** – Each insurance policy required above shall provide that coverage shall not be canceled, except with notice to the COUNTY.
4. **Waiver of Subrogation Rights** – **CONTRACTOR hereby agrees to waive rights of subrogation which any insurer of CONTRACTOR may acquire** from CONTRACTOR by virtue of the payment of any loss. CONTRACTOR agrees to obtain any endorsement that may be necessary to effect this waiver of subrogation. **The Workers' Compensation policy shall be endorsed with a waiver of subrogation** in favor of the COUNTY for all work performed by the CONTRACTOR, its employees, agents and subcontractors. This provision applies regardless of whether or not the COUNTY has received a waiver of subrogation endorsement from the insurer.
5. **Deductibles and Self-Insured Retention** – Any deductibles or self-insured retentions must be declared to and approved by the COUNTY. At the option of the COUNTY, either: the CONTRACTOR shall cause the insurer shall reduce or eliminate such deductibles or self-insured retentions as respects the COUNTY, its officers, officials, employees, agents and volunteers; or the CONTRACTOR shall provide a financial guarantee satisfactory to the COUNTY guaranteeing payment of losses and related investigations, claim administration, and defense expenses.
6. **Acceptability of Insurers** – Unless otherwise approved by Risk Management, insurance shall be written by insurers authorized to do business in the State of California and with a minimum A.M. Best's Insurance Guide rating of "A- VII".
7. **Verification of Coverage** – CONTRACTOR shall furnish the COUNTY with proof of insurance, original certificates and amendatory endorsements as required by this Agreement. The proof of insurance, certificates and endorsements are to be received and approved by the COUNTY before work commences. However, failure to obtain the required documents prior to the work beginning shall not waive the CONTRACTOR'S obligation to provide them. The CONTRACTOR shall furnish evidence of renewal of coverage throughout the term of the Agreement. The COUNTY reserves the right to require complete, certified copies of all required insurance policies, including endorsements required by these specifications, at any time.
8. **Failure to Procure Coverage** – In the event that any policy of insurance required under this Agreement does not comply with the requirements, is not procured, or is canceled and not replaced, COUNTY has the right but not the obligation or duty to terminate the Agreement. Maintenance of required insurance coverage is a material element of the Agreement and failure to maintain or renew such coverage or to provide evidence of renewal may be treated by COUNTY as a material breach of contract.
9. **Subcontractors** – CONTRACTOR shall require and verify that all subcontractors maintain insurance meeting all the requirements stated herein, and CONTRACTOR shall ensure that COUNTY is an additional insured on insurance required from subcontractors. For CGL coverage subcontractors shall provide coverage with a format least as broad as CG 20 38 04 13.

10. **Claims Made Policies** – If any of the required policies provide coverage on a claims-made basis:

- i. The Retroactive Date must be shown and must be before the date of the contract or the beginning of contract work.
- ii. Insurance must be maintained and evidence of insurance must be provided for at least five (5) years after completion of contract work.
- iii. If coverage is canceled or non-renewed, and not replaced with another claims-made policy form with a Retroactive Date prior to the contract effective date, the CONTRACTOR must purchase “extended reporting” coverage for a minimum of five (5) years after completion of contract work.

11. **Special Risks or Circumstances** – COUNTY reserves the right to modify these requirements, including limits, based on the nature of the risk, prior experience, insurer, coverage, or other circumstances.

Any change requiring additional types of insurance coverage or higher coverage limits must be made by amendment to this Agreement. CONTRACTOR agrees to execute any such amendment within thirty (30) days of receipt.

Any failure, actual or alleged, on the part of COUNTY to monitor or enforce compliance with any of the insurance and indemnification requirements will not be deemed as a waiver of any rights on the part of COUNTY.

Exhibit "D"
Change Order Form



County of Santa Barbara
General Services Department
Capital Projects Division

1105 Santa Barbara Street
Santa Barbara, California 93101
(805) 569-3055 FAX (805) 568-3249

CHANGE ORDER NO. {CCO NO.}

PROJECT TITLE: {PROJECT TITLE} PROJECT NO.: {PRJNO.}

CONTRACTOR: {LEGAL CONTRACTOR NAME} CONTRACT NO.: {CONT. NO.}

Except as provided herein, all terms and conditions of the contract referenced above remain unchanged and in full force and effect. The contractor may not exceed the price shown below without further written instruction from the Owner.

NOTE: This contract Change Order is not effective until signed by the Owner's Project manager and until signed by the Owner's Authorized Representative.

DESCRIPTION OF WORK TO BE PERFORMED:

The purpose of Contract Change Order {CCONO.} is:

By reason of this Change Order, the Contract Amount and Completion Date is hereby changed as shown below:

AMOUNT OF THIS CHANGE: {\$AMT} ADDT'L DAYS AWARDED: {NO.DAYS} DATE ISSUED: {DD/MM/YY}

We the undersigned have given careful consideration to all aspects of the change order proposed and hereby agree.

Contractor acknowledges receipt of this Change Order and the not to exceed amount stated above. Contractor understands that the final price for this work will be determined in accordance with General Conditions.
CONTRACTOR:
NAME AND TITLE OF SIGNER (Type or Print):
(Signature of person authorized to sign) Date

By signing below, Owner revises the Contract as provided above, in accordance with General Conditions.
OPM: (Type or Print)
Owner Project Manager Date
OAR NAME: {NAME}, Capital Division Manager
Owner's Authorized Representative Date

CONSTRUCTION DRAWINGS

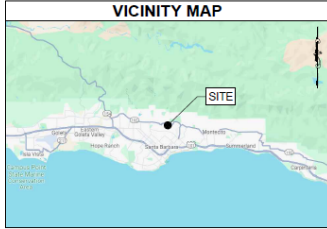

- SCOPE OF WORK**
- PROMISE AND INSTALL A STAINLESS STEEL MONOPOLE TOWER INCLUDING ALL DRILLING, STRUCTURAL STEEL, AND CONCRETE.
 - PROMISE AND INSTALL NEW 24" DIA. PRECAST CONCRETE EQUIPMENT SHELTER. IDEAL FOR APPLICATIONS THAT REQUIRE A SECURE FACILITY LOCATED UP TO 200' FROM COMPANY TO 425'-0" FROM CODE REQUIREMENTS. THE EQUIPMENT SHELTER UTILIZES 5000 PSI SOLID CONCRETE WITH #4 REINFORCING BARS MEETING ASTM A-601 GRADE 60 SPECIFICATIONS AND ASTM BUILDING CODE. SHELTER WILL BE SITUATED ON AN ENGINEERED CONCRETE SLAB.
 - PROMISE AND INSTALL SUPPORTS TRAY (SEE BRIDGE) FROM MONOPOLE TOWER TO THE SHELTER.
 - ELECTRICAL - PROMISE AND INSTALL NEW 200-AMP BREAKER AND ATS TO FIT INTO EXISTING SWITCHGEAR. THIS WILL PROVIDE ELECTRICAL TO THE SHELTER FOR LIGHTING, EQUIPMENT RACKS FOR THE ANTENNA AND HEAD.
 - REPLACE THE EXISTING 30 YEAR OLD GENERATOR AND INSTALL A NEW 50KW PROpane GENERATOR AND 500-GALLON TANK.
 - HVAC - PROMISE AND INSTALL HVAC UNITS TO THE SHELTER.

PREPARED FOR:

JVCKENWOOD



SITE NAME:

STB FIRE STATION 7

PROJECT DESCRIPTION:

RAW LAND NSB

PROJECT INFORMATION

SITE ADDRESS: 2411 STANWOOD DRIVE
 SANTA BARBARA, CA 93103
 LATITUDE: 34.443327 (NAD 83)
 LONGITUDE: -119.690333 (NAD 83)
 ACR: 051-120-012
 ZONE: R-1
 LOT SIZE: 105,488 sq ft / 3.19 ACRES
 AVERAGE SLOPE: 15%
 HILLSIDE DESIGN DISTRICT: YES
 HIGH RISK AREA: FLOOD ZONE: AE, X
 JURISDICTION: CITY OF SANTA BARBARA
 PROPERTY OWNER: CITY OF SANTA BARBARA
 APPLICANT: EP JOHNSON TECHNOLOGIES
 A. JAVKENWOOD COMPANY
 1440 CORPORATE DRIVE
 BEVING, TX 75005
 ENGINEER: FORESITE GROUP, LLC
 3740 RAMMO CT, SUITE 100
 FORTWORTH, TEXAS, CA 30092
 POWER: SOUTHERN CALIFORNIA Edison
 DESIGN DATA: CALIFORNIA BUILDING CODE 2022
 (VOL. 1 & 2) & TIA-222-H
 DESIGN CODE: CALIFORNIA BUILDING CODE 2022
 (VOL. 1 & 2) & TIA-222-H
 BASIC WIND SPEED: 104 MPH (3 SECOND GUST)
 EXPOSURE CATEGORY: C
 RISK CATEGORY: IV

SHEET INDEX

SHEET	DESCRIPTION	REV
T-1	TITLE SHEET	1
T-2	CONSTRUCTION NOTES	1
T-3	SITE BRIDGE	1
C-1	CONCRETE & REINFORCING	1
C-2	OVERALL SITE PLAN	1
C-3	ENHANCED SITE PLAN	1
C-4	GRADING & EROSION CONTROL PLAN	1
C-5	TOWER ELEVATION	1
C-6	SITE ELEVATION WITH TOWER ELEVATION	1
C-7	EQUIPMENT SLAB DETAILS	1
C-8	FOUNDATION DETAILS	1
C-9	CONCRETE	1
E-1	ELECTRICAL NOTES	1
E-2	ELECTRICAL SCHEDULE (SCHEDULE)	1
E-3	SITE SERVICE ROUTING & POWER CONFIG	1
E-4	PROPOSED GRADING PLAN	1
E-5	GRADING & EROSION CONTROL DETAILS	1
E-6	DIST DIST. DETAILS	1
E-7	H-FRAME DETAIL	1



811
 Know what's below.
 Call before you dig.
 CALL BEFORE YOU DIG
 811

JVCKENWOOD



FORESITE GROUP, LLC
 3740 RAMMO CT, SUITE 100
 FORTWORTH, TEXAS 76103
 PHONE: 817.758.1988
 FAX: 817.758.1988

PRELIMINARY

STB FIRE STATION 7
 SHEET NO. T-1
 TOTAL SHEETS 12

APPROVALS
 CARRIER: _____
 LANDLORD: _____
 LEASING: _____
 CONSTRUCTION: _____
 REVISIONS: _____ DATE: _____

ISSUED FOR: PRELIMINARY
 PROJECT MANAGER: DE
 DRAWING BY: TLL
 DATE: 8/19/2022
 TITLE: STB FIRE STATION 7
 SHEET NUMBER: T-1
 JOB/FILE NUMBER: 1562.027

- GENERAL NOTES:**
- FOR THE PURPOSE OF THE CONSTRUCTION DRAWINGS, THE FOLLOWING DEFINITIONS SHALL APPLY:
 CONTRACTOR - GENERAL CONTRACTOR (CONSTRUCTION)
 PROJECT MANAGER - TOWER SYSTEMS
 - PRIOR TO THE SUBMISSION OF THIS, THE BIDDING CONTRACTOR SHALL VISIT THE SITE TO FAMILIARIZE WITH THE EXISTING CONDITIONS AND TO CONFIRM THAT THE WORK CAN BE ACCOMMODATED AS SHOWN ON THE CONSTRUCTION DRAWINGS. ANY DISCREPANCY FOUND SHALL BE BROUGHT TO THE ATTENTION OF THE ENGINEER.
 - ALL MATERIALS FURNISHED AND INSTALLED SHALL BE IN STRICT ACCORDANCE WITH ALL APPLICABLE CODES, REGULATIONS AND ORDINANCES. CONTRACTOR SHALL FURNISH ALL APPLICABLE NOTICES AND COMPLY WITH ALL LAWS, ORDINANCES, RULES, REGULATIONS, AND LAWS, ORDERS OF ANY PUBLIC AUTHORITY REGARDING THE PERFORMANCE OF THE WORK.
 - ALL WORK CARRIED OUT SHALL COMPLY WITH ALL APPLICABLE MUNICIPAL AND UTILITY COMPANY SPECIFICATIONS AND LOCAL JURISDICTIONAL CODES, ORDINANCES AND APPLICABLE REGULATIONS.
 - UNLESS NOTED OTHERWISE, THE WORK SHALL INCLUDE FURNISHING MATERIALS, EQUIPMENT, APPURTENANCES, AND LABOR NECESSARY TO COMPLETE ALL INSTALLATIONS AS INDICATED ON THE DRAWINGS.
 - THE CONTRACTOR SHALL INSTALL ALL EQUIPMENT AND MATERIALS IN ACCORDANCE WITH MANUFACTURER'S RECOMMENDATIONS UNLESS SPECIFICALLY STATED OTHERWISE.
 - IF THE SPECIFIED EQUIPMENT CANNOT BE INSTALLED AS SHOWN ON THESE DRAWINGS, THE CONTRACTOR SHALL PROPRIETOR AN ALTERNATIVE INSTALLATION FOR APPROVAL BY THE ENGINEER.
 - CONTRACTOR SHALL DETERMINE ACTUAL ROUTING OF CONDUIT, POWER, FIBER, AND GROUNDING CABLES SHOWN ON THE POWER & GROUNDING DRAWINGS.
 - CONTRACTOR SHALL PROTECT EXISTING IMPROVEMENTS, PAVEMENTS, CURBS, LANDSCAPING AND STRUCTURES. ANY DAMAGED PART SHALL BE REPAIRED AT CONTRACTOR'S EXPENSE TO THE SATISFACTION OF THE OWNER.
 - CONTRACTOR SHALL LEGALLY AND PROPERLY DISPOSE OF ALL SCRAP MATERIALS OFF-SITE.
 - CONTRACTOR SHALL LEAVE PREMISES IN CLEAN CONDITION.
 - CONTRACTOR SHALL HAVE A RECONSTRUCTION DRAWING WHEN OBTAINING ALL ASPECTS OF THE CONSTRUCTION SCOPE OF THE WORKING TO ENSURE HE IS FAMILIAR AND UNDERSTANDS ALL REQUIREMENTS AND INTENT OF EACH ACTIVITY.
 - THE CONTRACTOR MUST VERIFY ALL DIMENSIONS, CONDITIONS AND ELEVATIONS BEFORE STARTING WORK. ALL DISCREPANCIES SHALL BE CALLED TO THE ATTENTION OF THE ENGINEER AND SHALL BE RESOLVED BEFORE PROCEEDING WITH THE WORK. ALL WORK SHALL BE REPERFORMED IN A WORKMANLIKE MANNER IN ACCORDANCE WITH ACCEPTED CONSTRUCTION PRACTICES.
 - IF IN THE INTEREST OF THESE DRAWINGS TO SHOW THE COMPLETE INSTALLATION, THE CONTRACTOR SHALL BE RESPONSIBLE FOR ALL TEMPORARY BRACKETS, SHORING, TIES, FORMWORK, ETC. IN ACCORDANCE WITH ALL NATIONAL, STATE AND LOCAL ORDINANCES, TO SAFELY EXECUTE ALL WORK AND SHALL BE RESPONSIBLE FOR SAME. ALL WORK SHALL BE IN ACCORDANCE WITH LOCAL CODES.
 - THE CONTRACTOR SHALL USE ADEQUATE NUMBER OF SKILLED WORKMEN WHO ARE PROPERLY TRAINED AND EXPERIENCED IN THE RESPECTIVE TRADES, AND WHO ARE COMPLETELY FAMILIAR WITH THE SPECIFIED REQUIREMENTS AND METHODS NEEDED FOR PROPER PERFORMANCE OF THE WORK.
 - CONTRACTOR AGREES THAT IN ACCORDANCE WITH GENERALLY ACCEPTED CONSTRUCTION PRACTICES, CONTRACTOR WILL BE REQUIRED TO ASSUME SOLE AND COMPLETE RESPONSIBILITY FOR JOB SITE CONDITIONS DURING THE COURSE OF CONSTRUCTION OF THE PROJECT, INCLUDING SAFETY OF ALL PERSONS AND PROPERTY. THIS RESPONSIBILITY SHALL BE MAINTAINED CONTINUOUSLY AND NOT LIMITED TO CONSTRUCTION OF THE PROJECT. CONTRACTOR SHALL BE RESPONSIBLE FOR ALL SAFETY DECISIONS MADE FROM ANY AND ALL QUALITY, IDEAL OR ALLEGED, IN CONNECTION WITH PERFORMANCE OF WORK ON THIS PROJECT. ALL WORK SHALL COMPLY WITH LOCAL AND STATE SAFETY REQUIREMENTS, PROCESSES FOR THE PROTECTION OF PUBLIC SAFETY, AND OTHERS SHALL BE ESTABLISHED PRIOR TO FOUNDATION INSTALLATION.
 - IF REQUIRED, CONTRACTOR TO COORDINATE PROPOSED DRIVEWAY CONNECTION PERMIT WITH STATE OR LOCAL DOT OFFICE.

- SITE WORK GENERAL NOTES:**
- THE CONTRACTOR SHALL CONTACT UTILITY LOCATING SERVICES PRIOR TO THE START OF CONSTRUCTION.
 - ALL EXISTING ACTIVE SEWER, WATER, GAS, ELECTRIC, AND OTHER UTILITIES WHICH ENCOUNTERED IN THE WORK SHALL BE PROTECTED AT ALL TIMES, AND AVOIDANCE REQUIRED FOR THE PROPER EXECUTION OF THE WORK SHALL BE SELECTION AS DIRECTED BY ENGINEER. EXTREME CAUTION SHOULD BE USED BY THE CONTRACTOR WHEN EXCAVATION OR DRILLING NEAR AROUND OR NEAR UTILITIES. CONTRACTOR SHALL PROVIDE SAFETY TRAINING FOR THE WORKING CREW. THIS WILL INCLUDE BUT NOT BE LIMITED TO: (A) FALL PROTECTION (B) CONFINED SPACE (C) ELECTRICAL SAFETY (D) TRENCHING & EXCAVATION.
 - ALL SITE WORK SHALL BE AS INDICATED ON THE DRAWINGS AND IN ACCORDANCE WITH ALL APPLICABLE CODES, REGULATIONS, AND ORDINANCES.
 - IF NECESSARY, RUBBER STAMPS, STAKES, STICKS, STONES, AND OTHER REFERENCE SHALL BE REMOVED FROM THE SITE AND DEPOSITED LEGALLY.
 - ALL EXISTING INACTIVE SEWER, WATER, GAS, ELECTRIC AND OTHER UTILITIES WHICH INTERFERE WITH THE EXECUTION OF THE WORK, SHALL BE REMOVED AND/OR CAPPED, PLUGGED OR OTHERWISE DISCONNECTED AT POINTS WHICH WILL NOT INTERFERE WITH THE EXECUTION OF THE WORK, SUBJECT TO THE APPROVAL OF OWNER AND/OR LOCAL UTILITY PROVIDER.
 - THE CONTRACTOR SHALL PROVIDE SITE STORAGE IN ACCORDANCE WITH THE TECHNICAL SPECIFICATIONS FOR SITE BRIDGE.
 - THE SITE SHALL BE PROTECTED TO CAUSE SURFACE WATER TO FLOW AWAY FROM THE SITE, EQUIPMENT AND TOWER AREAS.
 - NO FILL OR EMBARMENT MATERIAL SHALL BE PLACED ON FROZEN GROUND, FROZEN MATERIALS, SNOW, OR ICE SHALL NOT BE PLACED IN ANY FILL OR EMBARMENT.
 - THE SUB GRADE UNDER THE PROPOSED EQUIPMENT PAD SHALL BE COMPACTED TO THE PROCTOR AND BROUGHT TO A SMOOTH UNIFORM GRADE PRIOR TO FINISHED SURFACE APPLICATION.
 - THE AREAS OF THE OWNER'S PROPERTY DETRIMENT BY THE WORK AND NOT COVERED BY THE TOWER EQUIPMENT OR OTHERS SHALL BE GRADED TO A UNIFORM SLOPE AND STABILIZED TO PREVENT EROSION AS SPECIFIED IN THE DRAWINGS AND IN ACCORDANCE WITH ALL APPLICABLE CODES, REGULATIONS, AND ORDINANCES.
 - CONTRACTOR SHALL MINIMIZE OBSTRUCTION TO EXISTING SITE DURING CONSTRUCTION. EROSION CONTROL MEASURES, IF REQUIRED DURING CONSTRUCTION, SHALL BE IN CONFORMANCE WITH THE LOCAL, SUBSIDIES FOR EROSION AND SEDIMENT CONTROL.

- STRUCTURAL STEEL NOTES:**
- ALL WELDING SHALL BE PERFORMED USING E70XX ELECTRODES AND WELDING SHALL CONFORM TO AWS - W801 FILL METAL WELD WELD ARE NOT SHOWN PROVIDE THE MINIMUM SIZE PER TABLE 3.04 IN THE AWS "MANUAL OF STEEL CONSTRUCTION" PART 5 OR EXHAUSTIVE SURFACE SHALL BE TOUGHEN UP.
 - BOLTED CONNECTIONS SHALL BE ASIN AS32 BEARING TYPE CONNECTIONS AND SHALL HAVE MINIMUM OF TWO BOLTS UNLESS NOTED OTHERWISE.
- CONCRETE AND REINFORCING STEEL NOTES:**
- ALL CONCRETE WORK SHALL BE IN ACCORDANCE WITH ACI 301, ACI 318, ACI 336, ASTM A118.
 - ALL CONCRETE SHALL HAVE A MINIMUM COMPRESSIVE STRENGTH OF 4000 PSI AT 28 DAYS, UNLESS NOTED OTHERWISE. SLUMP: 7" MIN. 4" MAX. AIR ENTRAINMENT: 45 TO 65 BY VOLUME. MAXIMUM COARSE AGGREGATE SIZE SHALL BE 1 1/2".
 - REINFORCING STEEL SHALL CONFORM TO ASTM A 615, GRADE 60, DEFORMED UNLESS NOTED OTHERWISE. WELDING WIRE FABRIC SHALL CONFORM TO ASTM A 185. WELDED STEEL WIRE REINFORCEMENT UNLESS NOTED OTHERWISE SHALL BE CLASS "5" AND ALL BOLTS SHALL BE STANDARD UNLESS NOTED OTHERWISE.
 - THE FOLLOWING MINIMUM CONCRETE COVER SHALL BE PROVIDED FOR REINFORCING STEEL UNLESS SHOWN OTHERWISE ON DRAWINGS:
 CONCRETE CAST AGAINST EARTH: 3"
 CONCRETE EXPOSED TO EARTH OR WEATHER: 3"
 #6 AND LARGER: 4"
 #6 AND SMALLER: 3"
 CONCRETE NOT EXPOSED TO EARTH OR WEATHER OR NOT CAST AGAINST THE GROUND: 1 1/2"
 SLAB AND WALLS: 1 1/2"
 BEAMS AND COLUMNS: 1 1/2"
 - A CHAPER OF 3/8" SHALL BE PROVIDED AT ALL EXPOSED EDGES OF CONCRETE UNLESS NOTED OTHERWISE, IN ACCORDANCE WITH ACI 301.
 - INSTALLATION OF CONCRETE EXPANSION/SHRINK ANCHORS SHALL BE PER MANUFACTURER'S WRITTEN RECOMMENDED PROCEDURE. THE ANCHOR BOLT, DOUBLE OR TRIPLE SHALL CONFORM TO MANUFACTURER'S RECOMMENDATION FOR EMBEDMENT DEPTH OR AS SHOWN ON THE DRAWINGS. IF DRILLING IN EXISTING CONCRETE, NO EXISTING REBAR SHALL BE CUT WITHOUT PRIOR ENGINEERING APPROVAL.
 - WELDING IS PROHIBITED ON REINFORCING STEEL AND DIMENSIONS.
 - ALL CONCRETE SHALL BE READY-MIXED IN ACCORDANCE WITH ASTM C94, MAINTAIN TEMPERATURE OF CAST IN PLACE CONCRETE AT BETWEEN 50 DEGREES AND 90 DEGREES FAHRENHEIT.
 - DO NOT USE RETEMPERED CONCRETE OR ADD WATER TO READY-MIX CONCRETE AT THE SITE.
 - FOUNDATION INSTALLED SHALL INSURE THAT ALL PROTECTING THREADS OF PROPOSED ANCHOR BOLTS SHALL BE MAINTAINED CLEAN AND FREE OF CONCRETE.
 - FOUNDATION DESIGN IS BASED ON SOIL WITH 2000 PSF BEARING CAPACITY. IF EXISTING SOIL DOES NOT HAVE A MINIMUM 2000 PSF BEARING CAPACITY CONTRACTOR SHALL EXIST EXISTING BEAM TO REACH SOIL WITH MINIMUM 2000 PSF BEARING CAPACITY.

JVCKENWOOD



FORESITE GROUP, LLC
 3740 RAMMO CT, SUITE 100
 FORTWORTH, TEXAS 76103
 PHONE: 817.758.1988
 FAX: 817.758.1988

PRELIMINARY

STB FIRE STATION 7
 SHEET NO. T-2
 TOTAL SHEETS 12

APPROVALS
 CARRIER: _____
 LANDLORD: _____
 LEASING: _____
 CONSTRUCTION: _____
 REVISIONS: _____ DATE: _____

ISSUED FOR: PRELIMINARY
 PROJECT MANAGER: DE
 DRAWING BY: TLL
 DATE: 8/19/2022
 TITLE: STB FIRE STATION 7
 SHEET NUMBER: T-2
 JOB/FILE NUMBER: 1562.027



14"
10"

NOTICE RF SIGN (BLUE)
WHITE/BLUE BACKGROUND, WHITE/BLACK LETTERING.
MOUNTING LOCATION: GATE & CENTERLINE OF FENCING AROUND SITE. (CITY #1)
WHERE ADDRESS GATE INSTALLED (CITY #2)



12"

FCC REGISTRATION SIGN
WHITE/BLACK BACKGROUND, WHITE/BLACK LETTERING.
MOUNTING LOCATION: GATE & BASE OF TOWER.
QUANTITY: 2



10"

NOTICE AUTHORIZED PERSONNEL ONLY

AUTHORIZED PERSONNEL SIGN
WHITE/BLUE BACKGROUND, WHITE/BLACK LETTERING.
MOUNTING LOCATION: GATE & BASE OF TOWER.
QUANTITY: 1
WHERE ADDRESS GATE INSTALLED (CITY #2)



10"

DANGER NO TRESPASSING SIGN
WHITE/BLACK BACKGROUND, WHITE/BLACK LETTERING.
MOUNTING LOCATION: GATE & BASE OF TOWER.
QUANTITY: 2
WHERE ADDRESS GATE INSTALLED (CITY #2)

JVCKENWOOD

TOWER SYSTEMS
WE RISE

LEVEL-UP TOWERS

FORESITE group
Foresite Group LLC
10000 E. 1st Avenue, Suite 100
North Platte, Nebraska, NE 68103
Tel: 402.426.1000
Fax: 402.426.1001
www.foresitegroup.com

SEAL: _____

PRELIMINARY

PROJECT: **STB FIRE STATION #7**
SHEET #1 OF 1
SHEET TOTAL: 1 OF 1

APPROVALS:

CHECKED BY: _____ DATE: _____
DESIGNED BY: _____ DATE: _____
DRAWN BY: _____ DATE: _____
ISSUED FOR: _____ DATE: 6/19/2025

ISSUED FOR: PRELIMINARY
PROJECT MANAGER: DE
DRAWN BY: JLL
DATE: 6/19/2025
TITLE: SITE SIGNAGE

SHEET NUMBER: T-3
JOB/FILE NUMBER: 1562.027



Topographic Map
of a Portion of Santa Barbara City Fire Station No. 7
APN 021-120-012

Control Points:

Station	Method	Remarks
1	GPS	Control Point
2	GPS	Control Point
3	GPS	Control Point
4	GPS	Control Point
5	GPS	Control Point

Basis of Bearings:

The basis of bearings for this project is the National Magnetic Declination for the State of California, as published by the National Geospatial-Intelligence Agency, dated 2011.01.01, and adjusted for the year 2025.01.01.

Vertical Datum:

The vertical datum for this project is the National Vertical Datum for the State of California, as published by the National Geospatial-Intelligence Agency, dated 2011.01.01, and adjusted for the year 2025.01.01.

SURVEYOR'S NOTES:

- THE SURVEY COMPLETELY REPRESENTS A SURVEY PERFORMED IN THE FIELD ON THE DATE INDICATED ABOVE.
- ALL DISTANCES ARE GIVEN IN FEET AND DECIMALS THEREOF.
- ALL ANGLES ARE GIVEN IN DEGREES, MINUTES AND SECONDS.
- ALL BEARINGS ARE GIVEN AS TRUE BEARINGS.
- ALL CURVES ARE FULLY DEFINED BY THE CURVE DATA LISTED ON THIS MAP.
- ALL POINTS ARE PLACED ON THE MAP EXCEPT WHERE SHOWN OTHERWISE.
- ALL POINTS ARE PLACED ON THE MAP EXCEPT WHERE SHOWN OTHERWISE.
- ALL POINTS ARE PLACED ON THE MAP EXCEPT WHERE SHOWN OTHERWISE.
- ALL POINTS ARE PLACED ON THE MAP EXCEPT WHERE SHOWN OTHERWISE.
- ALL POINTS ARE PLACED ON THE MAP EXCEPT WHERE SHOWN OTHERWISE.

Legend:

○	Control Point
△	Survey Station
□	Property Line
▭	Building Footprint
▭	Asphalt Paved Area
▭	Gravel Paved Area
▭	Concrete Paved Area
▭	Grass
▭	Shrub
▭	Tree
▭	Water
▭	Other

Symbols:

○	Control Point
△	Survey Station
□	Property Line
▭	Building Footprint
▭	Asphalt Paved Area
▭	Gravel Paved Area
▭	Concrete Paved Area
▭	Grass
▭	Shrub
▭	Tree
▭	Water
▭	Other

TARTAGLIA ENGINEERING
Level Up Towers

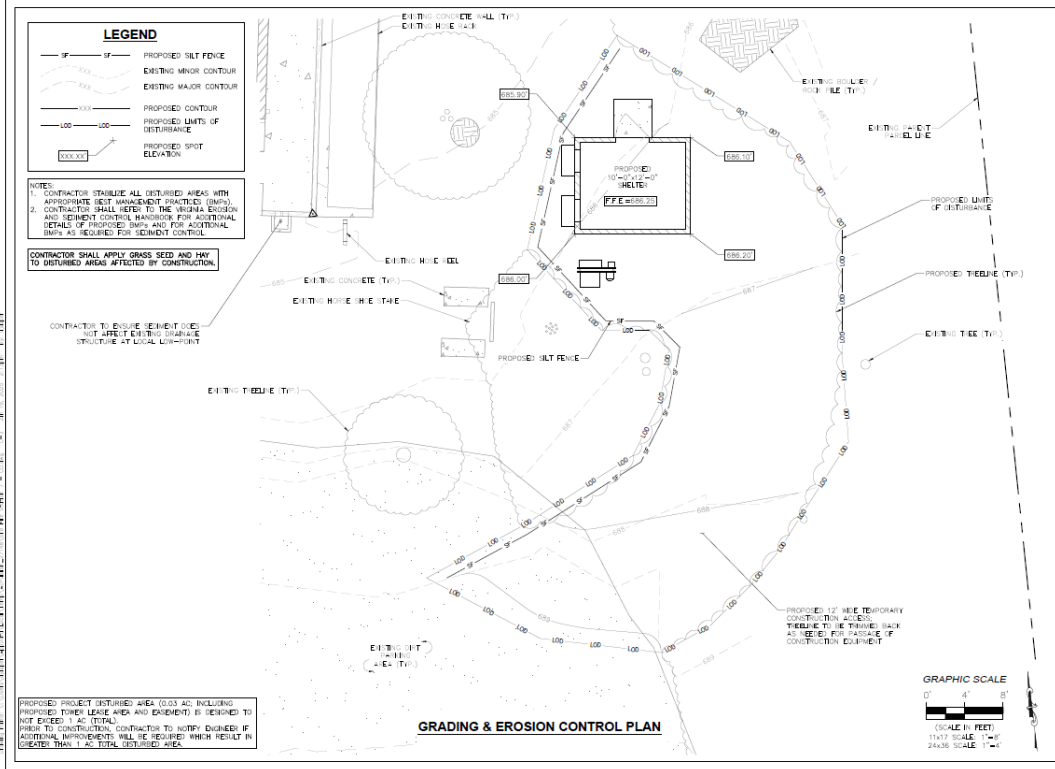

JVCKENWOOD

TOWER SYSTEMS
WE RISE

LEVEL-UP POWERS

FORESITE group
 Foresite Group, LLC
 2100 West 17th
 Suite 100
 Fort Worth, Texas, USA 76102

SEAL

PRELIMINARY

PROJECT: **STB FIRE STATION 7**
 1111 SOUTH 81ST AVENUE
 SOUTH BARRACKS, LA 70130

ISSUED FOR: PRELIMINARY
 PROJECT MANAGER: DE
 DRAWING BY: KLL
 DATE: 6/19/2022
 TITLE: EROSION GRADING & EROSION CONTROL PLAN
 SHEET NUMBER: C-3
 JOB/FILE NUMBER: 1562.027

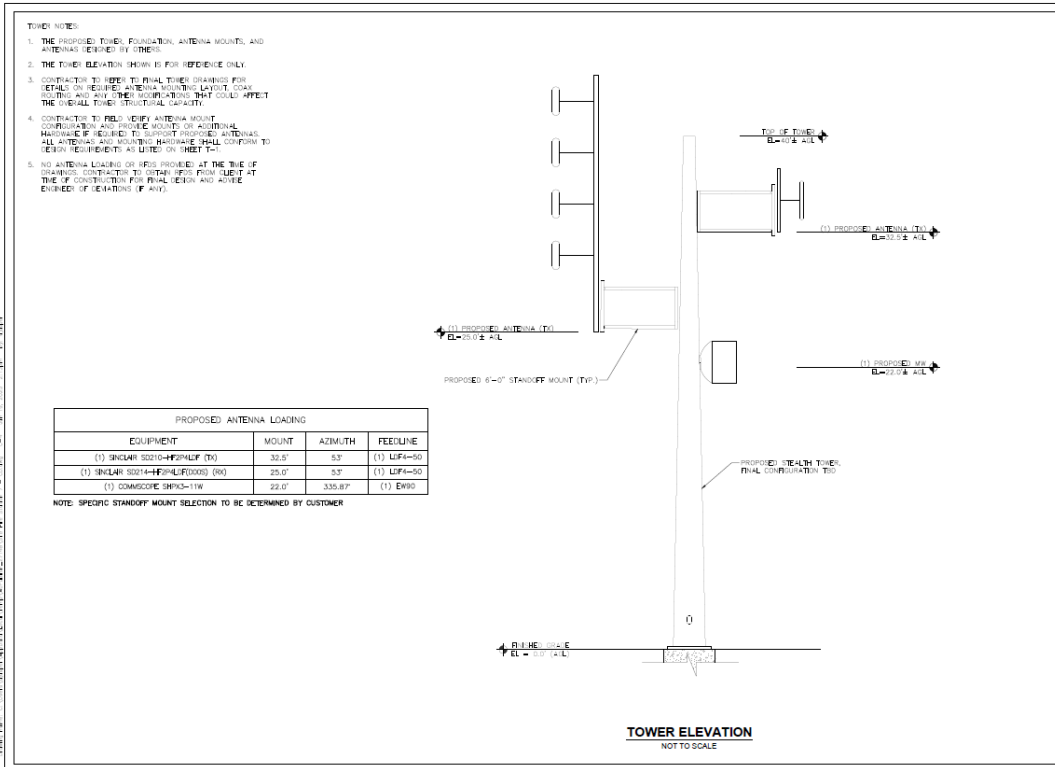

JVCKENWOOD

TOWER SYSTEMS
WE RISE

LEVEL-UP POWERS

FORESITE group
 Foresite Group, LLC
 2100 West 17th
 Suite 100
 Fort Worth, Texas, USA 76102

SEAL

PRELIMINARY

PROJECT: **STB FIRE STATION 7**
 1111 SOUTH 81ST AVENUE
 SOUTH BARRACKS, LA 70130

ISSUED FOR: PRELIMINARY
 PROJECT MANAGER: DE
 DRAWING BY: KLL
 DATE: 6/19/2022
 TITLE: TOWER ELEVATION
 SHEET NUMBER: C-4
 JOB/FILE NUMBER: 1562.027

FOUNDATION NOTE:

- FOUNDATION DESIGN IS BASED ON A 2000 PSF SOIL BEARING CAPACITY IF OTHER CONDITIONS EXIST FOUNDATION SHALL BE REDESIGNED. CONTRACTOR SHALL HAVE SOIL BEARING CAPACITY CHECKED BY A LICENSED PROFESSIONAL GEOTECHNICAL ENGINEER PRIOR TO INSTALLATION OF CONCRETE WITH THE CONCRETE SHALL BE 3000 PSI (MIN.) @ 28 DAYS.
- REBAR F₁ = #8@20" ON CENTER (MIN.) @ 28 DAYS.
- ALL REBAR SHALL BE TYPICALLY COMPACTED TO A MINIMUM OF ONE INCH USING THE APPROVED PROTECTIVE METHOD.
- SURFACE OF FINISHED SLAB SHALL BE LEVEL AND FLAT WITHIN 1/8".
- MAXIMUM TIE OF CONCRETE AGGREGATE SHALL NOT EXCEED 1.00". THE TIE SHALL BE INSTALLED WITHIN 12" OF THE BOTTOM OF THE THIRD REBAR WITHIN THE TIEING OR TIEING REBAR.
- REINFORCEMENT SHALL BE REBAR AND CONFORM TO THE REQUIREMENTS OF ASTM A615 GRADE 60 UNLESS OTHERWISE NOTED.
- WELDED WIRE FABRIC SHALL BE USED FOR REINFORCEMENT AND EQUIPMENT.
- MINIMUM CONCRETE COVER FOR REINFORCEMENT SHALL BE 3" UNLESS OTHERWISE NOTED. CONSIDER COVER FROM TOP OF FOUNDATION TO EDGE OF EXTERNAL REINFORCEMENT SHALL BE 3" UNLESS OTHERWISE NOTED.

CONCRETE NOTE:

- CONCRETE WORK SHALL BE PERFORMED IN ACCORDANCE WITH LATEST EDITION OF THE ACI CODE.
- REINFORCING STEEL SHALL BE PLACED IN ACCORDANCE WITH THE CONCRETE REINFORCING STEEL INSTITUTE (CSI) MANUAL OF STANDARD PRACTICE.
- FORMS SHALL BE PER CALIFORNIA BUILDING CODE 2022 (VCL 1 & 2).

NOTES:

- THIS DETAIL FOR REFERENCE ONLY. CONTRACTOR TO REFER TO SITE PLAN FOR ACTUAL ORIENTATION OF EQUIPMENT SLAB.
- VERIFY GENERATOR STOP UP AREA FOR SPECIFIC MANUFACTURER/MODEL NUMBER.
- TOTAL SLAB THICKNESS SHALL NOT EXCEED 10"

GENERATOR SLAB DETAIL
NOT TO SCALE

EQUIPMENT ANCHOR BOLT DETAIL
NOT TO SCALE

SECTION A
NOT TO SCALE

PRELIMINARY

PROJECT: **STB FIRE STATION 7**

ISSUED FOR: **PRELIMINARY**

PROJECT MANAGER: **KE**

DRAWING BY: **ELL**

DATE: **6/19/2025**

TITLE: **EQUIPMENT SLAB DETAILS**

SHEET NUMBER: **C-6**

JOB/FILE NUMBER: **1562.027**

FOUNDATION NOTE:

- SLAB TO BE LEVEL (±) 1/4".
- FOOTING TO BE MINIMUM OF 24" BELOW UNDISTURBED SOIL AND 6" BELOW THE FROST LINE.
- FINAL SITE DESIGN IS THE RESPONSIBILITY OF THE CONTRACTOR.
- SLAB FOUNDATION DESIGNED ASSUMING ALLOWABLE SOIL BEARING PRESSURE OF 2000 PSF.
- SLAB FOUNDATION DESIGNED ASSUMING MAXIMUM SOIL PLASTICITY INDEX OF 27.
- FOUNDATION SHALL HAVE A MINIMUM 6" PROJECTION ABOVE GRADE.
- CONCRETE STRENGTH SHALL BE A MINIMUM OF 4000 PSI @ 28 DAYS.
- STOOP SHALL BE A MINIMUM 6000 PSI.
- THE DOWN CONNECTION PLATE SHALL BE INSTALLED ABOVE GRADE.
- REINFORCING STEEL SHALL CONFORM TO ASTM A615 GRADE 60 UNLESS OTHERWISE NOTED. OTHERWISE, WELDED WIRE FABRIC SHALL CONFORM TO ASTM A185 WELDED STEEL WIRE FABRIC (UNLESS NOTED OTHERWISE). SPICES SHALL BE CLASS 70" AND ALL BOLTS SHALL BE STANDARD (UNLESS NOTED OTHERWISE).
- ALL REQUIRED: THE DOWN PLATES, SMALL BOLTS AND ANCHORS SHALL BE PLACED INSIDE SHELTER PRIOR TO SHIMMY FROM MANUFACTURER.
- USE SHIMS AS REQUIRED TO ASSURE SHELTER IS BEARING AT PERIMETER. SEAL PERIMETER +/- GROUT IF SHIMS ARE USED.
- TOP 6" OF FOUNDATION SERIES MUST BE FORMED FLAT TO ACCOMMODATE THE DOWN PLATES.
- CONTRACTOR TO VERIFY SHELTER FABRICATOR'S FOUNDATION SPECIFICATIONS.
- NOTES, DETAILS AND SPECIFICATIONS ON THIS PLAN DETAIL TO THE CONCRETE FOUNDATION FOR THE SHELTER. ONLY SHELTER DESIGN AND SPECIFICATIONS ARE THE RESPONSIBILITY OF OTHERS.

SHELTER FOUNDATION DETAIL:

SHELTER FOUNDATION DETAIL
NOT TO SCALE

STOOP DETAIL
NOT TO SCALE

SECTION A
NOT TO SCALE

SECTION B
NOT TO SCALE

SECTION C
NOT TO SCALE

PRELIMINARY

PROJECT: **STB FIRE STATION 7**

ISSUED FOR: **PRELIMINARY**

PROJECT MANAGER: **KE**

DRAWING BY: **ELL**

DATE: **6/19/2025**

TITLE: **SHELTER FOUNDATION DETAILS**

SHEET NUMBER: **C-7**

JOB/FILE NUMBER: **1562.027**

ELECTRICAL INSTALLATION NOTES

1. ALL ELECTRICAL WORK SHALL BE PERFORMED IN ACCORDANCE WITH THE PROJECT SPECIFICATIONS, NEC AND ALL APPLICABLE LOCAL CODES.
2. ALL ELECTRICAL EQUIPMENT AND ACCESSORIES SHALL BE UL APPROVED OR LISTED.
3. CONDUIT ROUTINGS ARE SOLELY THE CONTRACTOR'S RESPONSIBILITY. CONDUITS SHALL BE INSTALLED SO THAT ACCESS TO EQUIPMENT IS NOT BLOCKED.
4. WIRING, RACEWAY AND SUPPORT METHODS AND MATERIALS SHALL COMPLY WITH THE REQUIREMENTS OF THE NEC.
5. ALL CIRCUITS SHALL BE IDENTIFIED AND MAINTAIN MINIMUM CABLE SEPARATION AS REQUIRED BY THE NEC.
6. CABLES SHALL NOT BE ROUTED THROUGH LADDER-SHAPE CABLE TRAY RUNGS.
7. EACH END OF EVERY POWER, POWER PHASE CONDUCTOR (I.E. HOT), GROUNDING, AND IT CONDUCTOR AND CABLE SHALL BE LABELED WITH COLOR-CODED INSULATION OR ELECTRICAL TAPE (3/4 INCH WIDE, 1/2 INCH PLASTIC ELECTRICAL TAPE WITH HV PROTECTION, OR EQUAL). THE IDENTIFICATION METHOD SHALL CONFORM WITH NEC 404.6.
8. ALL ELECTRICAL COMPONENTS SHALL BE CLEARLY LABELED WITH ENGRAVED LAMACOOD PLASTIC LABELS. ALL EQUIPMENT SHALL BE LABELED WITH THEIR VOLTAGE RATING, PHASE CONFIGURATION, WIRE CONFIGURATION, POWER OR AMPACITY RATING, AND BRANCH CIRCUIT ID NUMBERS (I.E. PANELBOARD AND CIRCUIT ID'S).
9. PANELBOARDS (ID NUMBERS) AND INTERNAL CIRCUIT BREAKERS (CIRCUIT ID NUMBERS) SHALL BE CLEARLY LABELED WITH ENGRAVED LAMACOOD PLASTIC LABELS.
10. POWER, CONTROL, AND EQUIPMENT GROUND WIRING IN TUBING OR CONDUIT SHALL BE SINGLE CONDUCTOR (#14 AWG OR LARGER), 600 V, OIL RESISTANT RHM-2 OR XHHW-2, STRANDED COPPER CABLE RATED FOR 90°C (WET AND DRY) OPERATION, LISTED OR LABELED FOR THE LOCATION AND RACEWAY SYSTEM USED, UNLESS OTHERWISE SPECIFIED.
11. POWER AND CONTROL WIRING, NOT IN TUBING OR CONDUIT, SHALL BE MULTI-CONDUCTOR, TYPE UNIC-2 CABLE (1/4 AWG OR LARGER), 600 V, OIL RESISTANT RHM-2 OR XHHW-2, STRANDED COPPER CABLE RATED FOR 90°C (WET AND DRY) OPERATION, WITH OUTER JACKET, LISTED OR LABELED FOR THE LOCATION USED, UNLESS OTHERWISE SPECIFIED.
12. ALL POWER AND GROUNDING CONNECTIONS SHALL BE DRINK-SAFE, COMPRESSION WIRE LUGS AND NUTS BY THOMAS AND BETTS (OR EQUAL). LUGS AND NUTS SHALL BE RATED FOR OPERATION AT NO LESS THAN 90°C.
13. RACEWAY AND CABLE TRAY SHALL BE LISTED OR LABELED FOR ELECTRICAL USE IN ACCORDANCE WITH NEMA, UL, ANSI/IEEE, AND NEC.
14. ELECTRICAL METALLIC TUBING (EMT) OR RIGID METALLIC CONDUIT (RMC) SHALL BE USED FOR EXPOSED INDOOR LOCATIONS.
15. ELECTRICAL METALLIC TUBING (EMT) OR RIGID METALLIC CONDUIT (RMC) SHALL BE USED FOR CONCEALED INDOOR LOCATIONS.
16. RIGID NON-METALLIC CONDUIT (I.E., RIGID PVC SCHEDULE 80) SHALL BE USED UNDERGROUND, DIRECT BURIED, IN AREAS OF OCCASIONAL LIGHT VEHICLE TRAFFIC, OR IN AREAS OF HEAVY VEHICLE TRAFFIC; GALVANIZED RIGID CONDUIT SHALL BE USED.
17. ALL OUTDOOR EXPOSED CONDUIT SHALL BE RMC AND SHALL BE SUPPORTED ADEQUATELY.
18. LIQUID-TIGHT FLEXIBLE METALLIC CONDUIT (LMFC) SHALL BE USED INDOORS AND OUTDOORS, WHERE VIBRATION OCCURS OR FLEXIBILITY IS NEEDED. LMFC SHALL CONFORM TO NEC ARTICLE 350.
19. CONDUIT AND TUBING FITTINGS SHALL BE THREADED OR COMPRESSION-TYPE AND APPROVED FOR THE LOCATION USED. NET SOCKET FITTINGS ARE NOT ACCEPTABLE.
20. CABINETS, BOXES, AND WIRERAYS SHALL BE LISTED OR LABELED FOR ELECTRICAL USE IN ACCORDANCE WITH NEMA, UL, ANSI/IEEE, AND NEC.
21. WIRERAYS SHALL BE EPOXY-COATED (GRAY) AND INCLUDE A MINVED COVER, DESIGNED TO SLANG OPEN DOWNWARD, SHALL BE PAINTED TYPE E (OR EQUAL), AND RATED NEMA 1 (OR BETTER) INDOORS, OR NEMA 3R (OR BETTER) OUTDOORS.
22. EQUIPMENT CABINETS, TERMINAL BOXES, JUNCTION BOXES, AND PULL BOXES SHALL BE GALVANIZED OR EPOXY-COATED SHEET STEEL. SHALL MEET OR EXCEED UL 50, AND RATED NEMA 1 (OR BETTER) INDOORS, OR WEATHER PROTECTED (WP OR BETTER) OUTDOORS.
23. METAL RECEPTACLE SWITCH AND DEVICE BOXES SHALL BE GALVANIZED, EPOXY-COATED, OR NON-CORRODING. SHALL MEET OR EXCEED UL 514A AND NEMA OS 1 (OR BETTER) INDOORS, OR WEATHER PROTECTED (WP OR BETTER) OUTDOORS.
24. NON-METALLIC RECEPTACLE SWITCH AND DEVICE BOXES SHALL MEET OR EXCEED NEMA OS 2, AND RATED NEMA 1 (OR BETTER) INDOORS, OR WEATHER PROTECTED (WP OR BETTER) OUTDOORS.
25. CONTRACTOR SHALL APPLY FOR ELECTRICAL SERVICE AS SOON AS POSSIBLE AND COORDINATE REQUIREMENTS, SERVICE ROUTING, AND METER SOCKET TYPE WITH LOCAL POWER COMPANY.

ELECTRICAL INSTALLATION NOTES (CONT.)

26. CONTRACTOR SHALL APPLY FOR TELEPHONE SERVICE AS SOON AS POSSIBLE AND COORDINATE REQUIREMENTS AND SERVICE ROUTING WITH TELEPHONE COMPANY.
27. CONTRACTOR SHALL OBTAIN ALL PERMITS, PAY PERMIT FEES, AND SCHEDULE INSPECTIONS.
28. ALL SAFETY SWITCHES SHALL BE NEMA 1 FOR INDOOR, NEMA 3R FOR OUTDOOR, UL LISTED 200K SOCR RATED, REJECTION TYPE, WITH 100 FUSES. FUSES SHALL HAVE AN AMP OF 200K AND SHALL HAVE A LIMITING RATING AS SHOWN IN THESE DRAWINGS. EQUIPMENT AND ACCESSORIES SHALL BE RATED FOR 75 DEGREES CELSIUS OR HIGHER.
29. ALL LEAD CONDUITS SHALL BE 45 SPIKE UNLESS NOTED OTHERWISE. NEMA 1 FOR INDOOR, NEMA 3R FOR OUTDOOR, MSB WITH CONVENTIONAL WANG, UL LISTED 20K 1A OR HIGHER, WITH 20K AIR BREAKERS, BREAKERS AND LOAD CENTER SHALL BE RATED FOR 75 DEGREES CELSIUS OR HIGHER. BREAKERS SHALL HAVE A LIMITING RATING AS SPECIFIED ON THESE DRAWINGS.
30. CONTRACTOR SHALL LABEL ELECTRICAL EQUIPMENT IN ACCORDANCE WITH NEC 110.16 AND 110.24.
31. CONTRACTOR SHALL VERIFY THAT THE MAIN BONDING JUMPER AND GROUNDING ELECTRODE CONDUCTOR IS INSTALLED PROPERLY AT SERVICE ENTRANCE.
32. CONTRACTOR SHALL SEAL AROUND ALL CONDUIT PENETRATIONS TO PREVENT MOISTURE PENETRATION OR WEATHER INFILTRATION.
33. DURING TRENCH BACK-FILLING FOR EACH UNDERGROUND ELECTRICAL, TELEPHONE, SIGNAL AND COMMUNICATIONS LINE, PROVIDE A CONTINUOUS UNDERGROUND WARNING TAPE TWELVE INCHES BELOW FINISHED GRADE.

GROUNDING NOTES:

1. ALL GROUNDING CONNECTIONS SHALL BE MADE USING EXOTHERMIC WELDING PROCESS (GAS WELD OR EQUAL) EXCEPT FOR EQUIPMENT THAT MAY BE MECHANICALLY FASTENED. ALL LUGS SHALL BE TWO HOLE LONG BARREL TYPE, FOR COPPER, UNLESS OTHERWISE NOTED.
2. ALL GROUND RODS SHALL BE INSTALLED AT 30" BELOW GRADE PER MANUFACTURER'S SPECIFICATIONS. UNDERGROUND GROUNDING CONDUCTORS SHALL BE 30" BELOW GRADE.
3. ALL EXTERIOR GROUND CONDUCTORS SHALL BE MIN. #6 AWG SIZED THINW GAGE COPPER WIRE. EQUIPMENT GROUND CONDUCTORS SHALL BE MIN. #6 GREEN INSULATED, UNLESS OTHERWISE NOTED.
4. GROUND RODS FOR GROUND RING SHALL BE SPACED AT BETWEEN 2 X LENGTH OF ROD (MIN) AND 2.5 X LENGTH OF ROD (MAX) TO MAXIMIZE EFFICIENCY.
5. ANY METAL OBJECT WITHIN 6 FEET OF THE TOWER OR EQUIPMENT GROUND RING SHALL BE BONDED DIRECTLY TO THE RING.
6. THE MINIMUM BENDING RADIUS FOR ALL GROUNDING CONDUCTORS #6 AWG OR LARGER SHALL BE 24".
7. ALL ABOVE GRADE GROUND CONDUCTORS SHALL BE ROUTED DOWNWARD TOWARD EARTH AND HORIZONTAL ONLY WHERE NECESSARY.
8. ALL CONDUCTORS SHALL BE ROUTED SUCH THAT THERE ARE NO INCLUDED ANGLES OF LESS THAN 90 DEGREE.
9. PRIOR TO CONNECTING TO UTILITY, THE CONTRACTOR SHALL PERFORM IEEE FALL-OF-POTENTIAL RESISTANCE TO EARTH TESTING (PER IEEE 1100 AND #1) FOR GROUND ELECTRICITY SYSTEMS. THE SUBCONTRACTOR SHALL FURNISH AND INSTALL SUPPLEMENTAL GROUND ELECTRODES AS NEEDED TO ACHIEVE A RECOMMENDED TEST RESULT OF 3 OHMS OR LESS INDEPENDENT OF UTILITY GROUND.
10. ALL GROUNDING SHALL COMPLY WITH THE N.E.C. AND UL954 LIGHTNING PROTECTION STANDARD.
11. ALL GROUNDING COMPONENTS SHALL BE FURNISHED AND INSTALLED BY CONTRACTOR.
12. ANY METAL CONDUIT MOUNTED ON THE TOWER SHALL BE BONDED TO THE TOWER AT EACH END.
13. ALL EXPOSED GROUNDING SHALL BE IN NON-METALLIC FLEX CONDUIT AND SECURED AS NECESSARY.
14. WHEN BONDED TO EQUIPMENT, REMOVE PAINT TO BARE STEEL AND PROTECT WITH A COATING OF NO-OX.
15. APPROVED ANTIOXIDANT COATINGS SHALL BE USED ON ALL COMPRESSION AND BOLTED GROUND CONNECTIONS.
16. BOND ICE BRIDGE SECTIONS TOGETHER EXOTHERMICALLY OR WITH 2 HOLE LUGS. BOND ICE BRIDGE TO SUPPORT POSTS.
17. THESE NOTES ARE NOT ALL-DICTIONARY. REFER TO CARRIER/TOWER OWNER FOR COMPLETE GROUNDING GUIDELINES.

JVCKENWOOD

TOWER SYSTEMS. WE RISE

LEVEL-UP TOWERS

FORESITE group

SEAL

PRELIMINARY

PROJECT: **STB FIRE STATION 7**

LOCATION: **3111 SOUTH 181 STREET, SANTA BARBARA, CA 93109**

CARRIER: _____ APPROVALS

LANDLORD: _____

LEASING: _____

CONSTRUCTION: _____

REVISIONS: _____ DATE: _____

ISSUED FOR: **PRELIMINARY**

PROJECT MANAGER: **DE**

DRAWING BY: **MLL**

DATE: **6/19/2025**

TITLE: **ELECTRICAL NOTES**

SHEET NUMBER: **E-1**

JOB/FILE NUMBER: **1562.027**

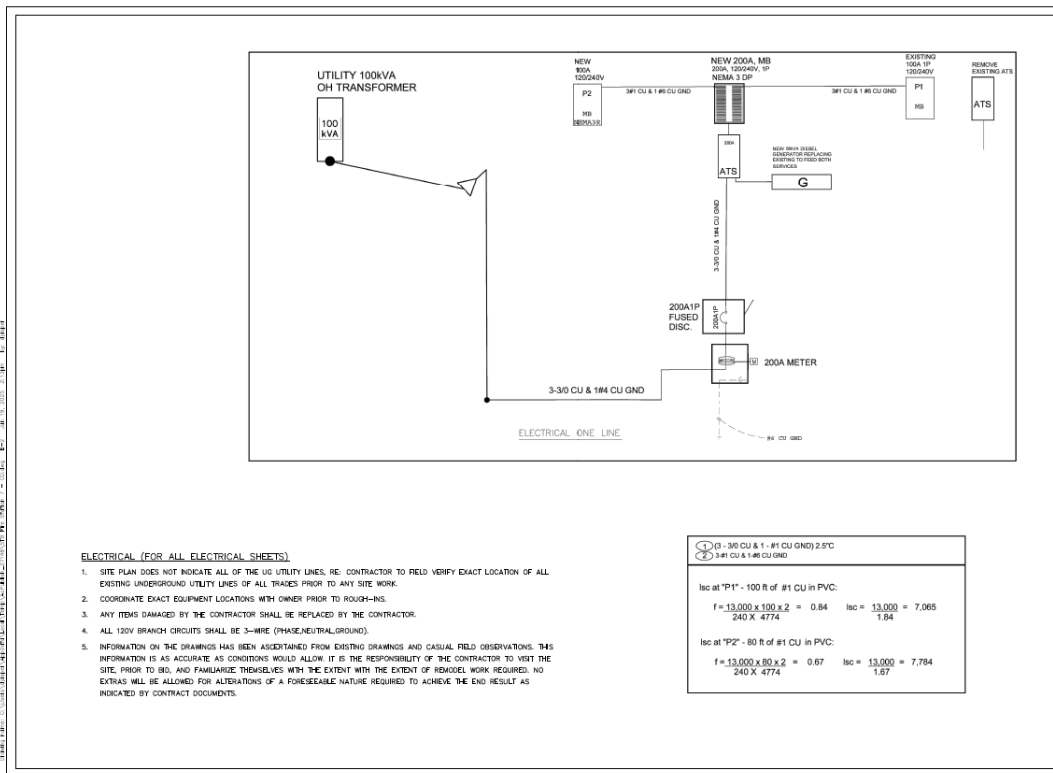

JVCKENWOOD

TOWER SYSTEMS. WE RISE

LEVEL-UP TOWERS

FORESITE group

SEAL

PRELIMINARY

PROJECT: **STB FIRE STATION 7**

LOCATION: **3111 SOUTH 181 STREET, SANTA BARBARA, CA 93109**

CARRIER: _____ APPROVALS

LANDLORD: _____

LEASING: _____

CONSTRUCTION: _____

REVISIONS: _____ DATE: _____

ISSUED FOR: **PRELIMINARY**

PROJECT MANAGER: **DE**

DRAWING BY: **MLL**

DATE: **6/19/2025**

TITLE: **ELECTRICAL ONE-LINE DIAGRAM**

SHEET NUMBER: **E-2**

JOB/FILE NUMBER: **1562.027**



JVCKENWOOD

TOWER SYSTEMS
 WE RISE

LEVEL-UP
 TOWERS

FORESIGHT
 group

ForeSite Group, LLC
 27400 Highway 101
 Suite 100
 Peachtree Corners, GA 30091

SEAL

PRELIMINARY

SEE FINAL POWER CONFIGURATION ON SHEET E-7

THE EXISTING ATC OFFICE IS HERE AFTER POWER OUT OVER

ADD 100A BREAKER FOR DISCONNECT TO EXISTING PANEL

THE EXISTING POWER METER OFFLINE & REMOVE AFTER POWER OUT OVER

EXISTING & PROPOSED FIRE STATION POWER CONFIGURATION

PROJECT

STB FIRE STATION 7

17100 HWY 20
 1111 SOUTH LEXIE
 WOOD BRIDGE, VA 22190

APPROVALS

DESIGNED BY _____

REVISIONS _____ DATE _____

REVISED FOR: PROJECTIONS

PROJECT MANAGER: DE

DRAWING BY: KLL

DATE: 6/19/2023

TITLE: **SITE SERVICE ROUTING & POWER CONFIG.**

SHEET NUMBER: **E-3**

JOB/FILE NUMBER: 1562.027

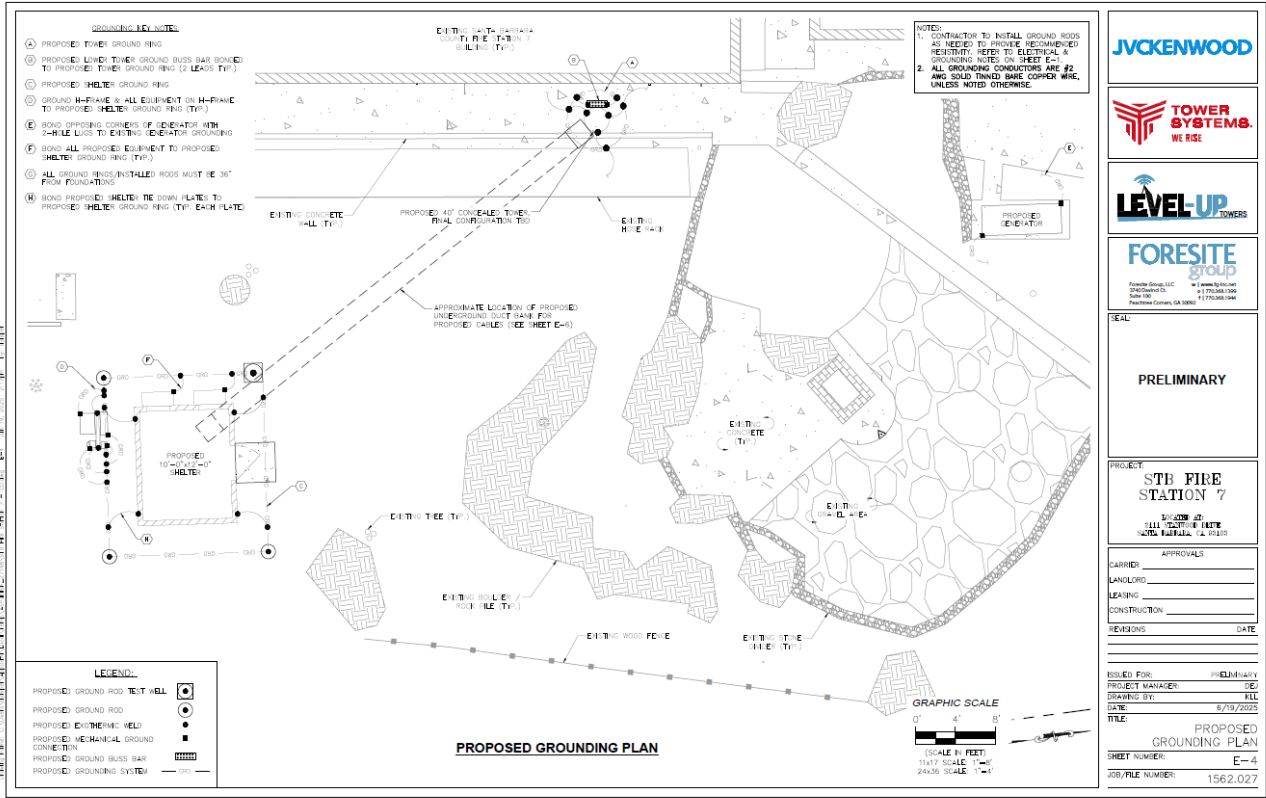

JVCKENWOOD

TOWER SYSTEMS
WE RISE

LEVEL-UP
TOWERS

FORESITE group
 Foresite Group, LLC
 2800 Chesapeake Blvd.
 Suite 100
 Pasadena, CA 91106
 +1 714.268.0000
 +1 714.268.0000

SEAL: _____

PRELIMINARY

PROJECT: **STB FIRE STATION 7**
 1111 SOUTH OF LEXY SOUTH FAIRFAX, VA 22033

APPROVALS:

CARRIED BY: _____
 LANDLORD: _____
 LEASING: _____
 CONSTRUCTION: _____
 REVISIONS: _____ DATE: _____

ISSUED FOR: PRELIMINARY
 PROJECT MANAGER: DEJ
 DRAWING BY: RLL
 DATE: 6/19/2022
 TITLE: PROPOSED GROUNDING PLAN
 SHEET NUMBER: E-4
 JOB/FILE NUMBER: 1562.027

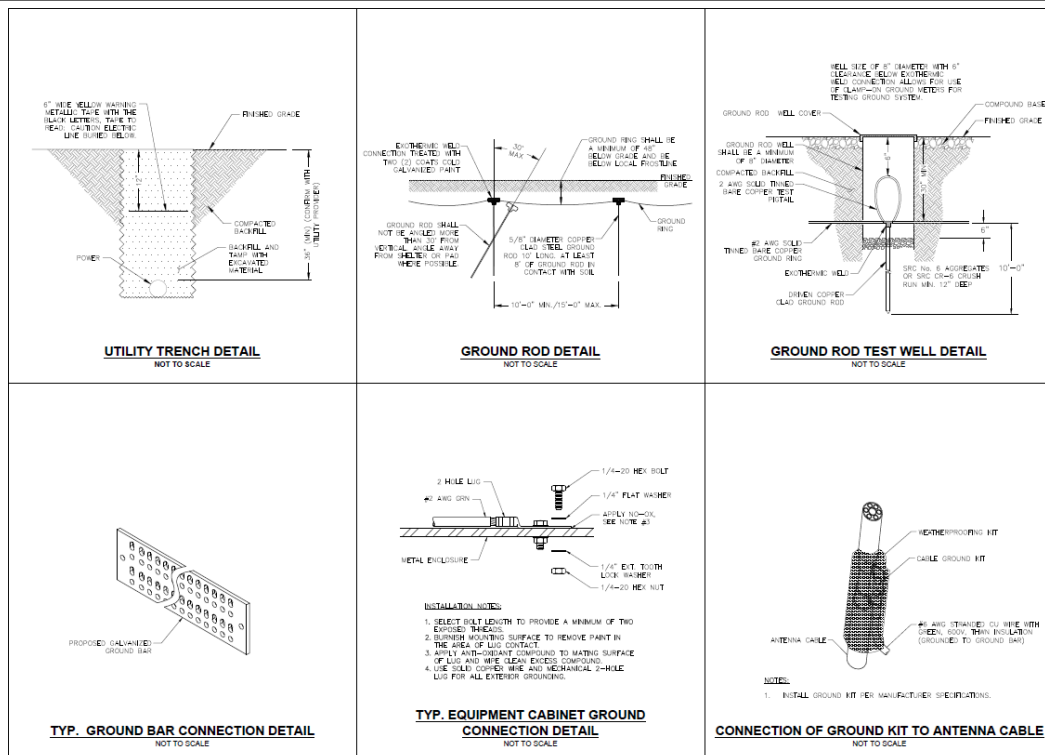

JVCKENWOOD

TOWER SYSTEMS
WE RISE

LEVEL-UP
TOWERS

FORESITE group
 Foresite Group, LLC
 2800 Chesapeake Blvd.
 Suite 100
 Pasadena, CA 91106
 +1 714.268.0000
 +1 714.268.0000

SEAL: _____

PRELIMINARY

PROJECT: **STB FIRE STATION 7**
 1111 SOUTH OF LEXY SOUTH FAIRFAX, VA 22033

APPROVALS:

CARRIED BY: _____
 LANDLORD: _____
 LEASING: _____
 CONSTRUCTION: _____
 REVISIONS: _____ DATE: _____

ISSUED FOR: PRELIMINARY
 PROJECT MANAGER: DEJ
 DRAWING BY: RLL
 DATE: 6/19/2022
 TITLE: GROUNDING & TRENCHING DETAILS
 SHEET NUMBER: E-5
 JOB/FILE NUMBER: 1562.027

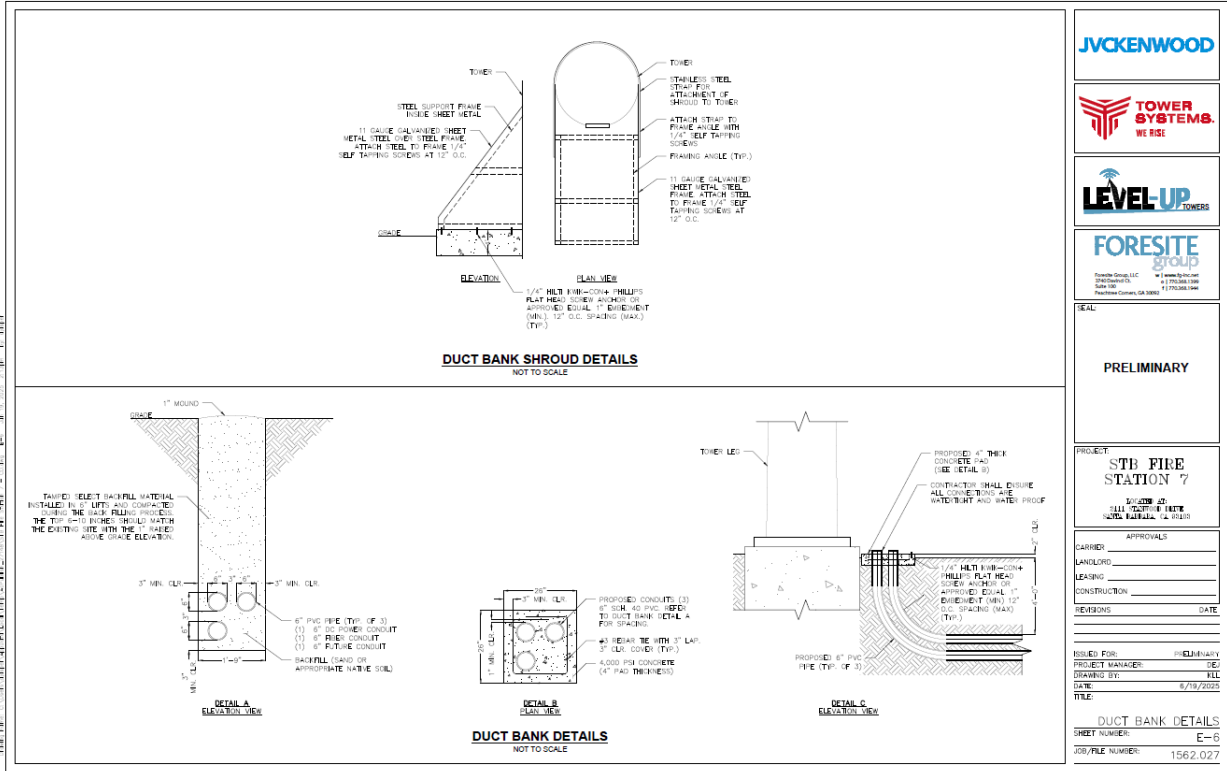

JVCKENWOOD

TOWER SYSTEMS
WE RISE

LEVEL-UP TOWERS

FORESITE group
Foresite Group, LLC
2200 Westwood Blvd
Suite 100
Pasadena, CA 91105
www.foresitegroup.com
P: 774.266.1999
F: 774.266.1999

DATE: _____

PRELIMINARY

PROJECT: **STB FIRE STATION 7**
SHEET NO. **111** OF **111** SHEETS OF **111**
DATE: **06/18/2020**

APPROVALS	
CARRIED	DATE
LANDLORD	DATE
LEASING	DATE
CONSTRUCTION	DATE
REVISIONS	DATE

ISSUED FOR: **PRELIMINARY**

PROJECT MANAGER: **KE**

DRAWN BY: **KLL**

DATE: **6/19/2020**

TITLE: **DUCT BANK DETAILS**

SHEET NUMBER: **E-6**

JOB/FILE NUMBER: **1562.027**

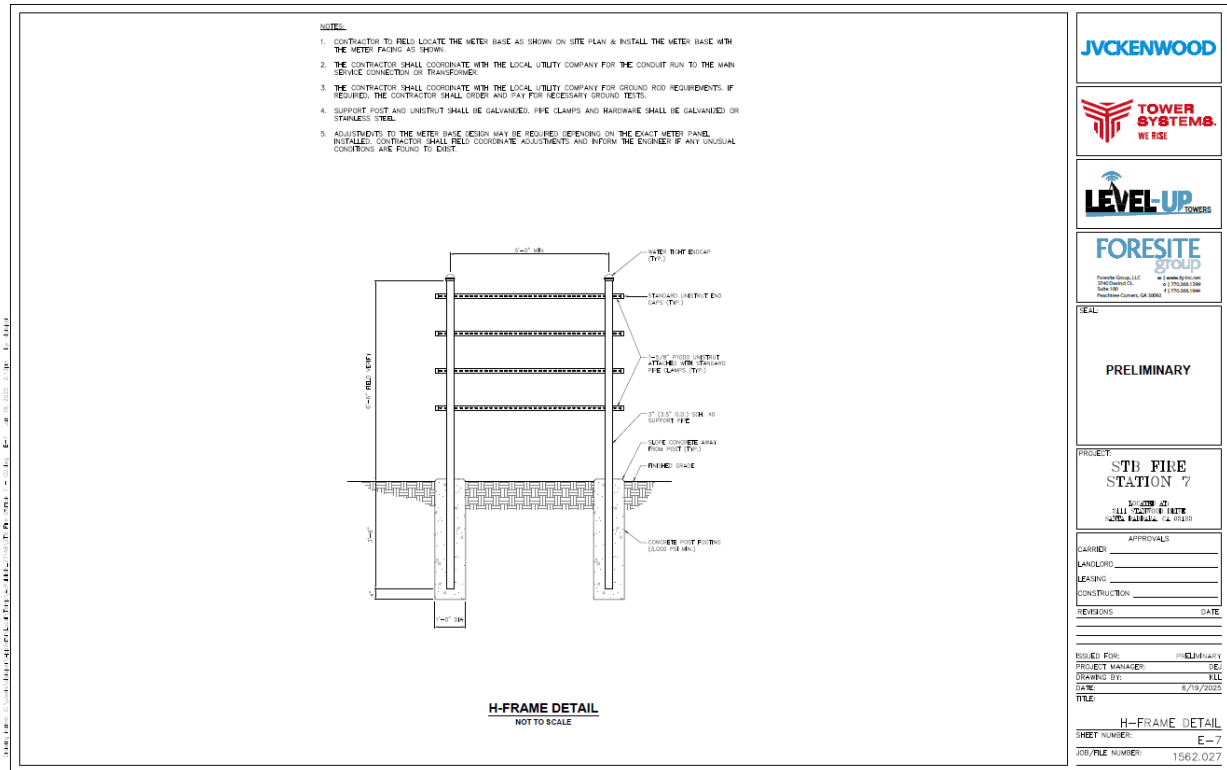

JVCKENWOOD

TOWER SYSTEMS
WE RISE

LEVEL-UP TOWERS

FORESITE group
Foresite Group, LLC
2200 Westwood Blvd
Suite 100
Pasadena, CA 91105
www.foresitegroup.com
P: 774.266.1999
F: 774.266.1999

DATE: _____

PRELIMINARY

PROJECT: **STB FIRE STATION 7**
SHEET NO. **111** OF **111** SHEETS OF **111**
DATE: **06/18/2020**

APPROVALS	
CARRIED	DATE
LANDLORD	DATE
LEASING	DATE
CONSTRUCTION	DATE
REVISIONS	DATE

ISSUED FOR: **PRELIMINARY**

PROJECT MANAGER: **KE**

DRAWN BY: **KLL**

DATE: **6/19/2020**

TITLE: **H-FRAME DETAIL**

SHEET NUMBER: **E-7**

JOB/FILE NUMBER: **1562.027**

SPECIFICATIONS

22039 Public Safety Radio Network Tower Specifications

1. Design Criteria

- 1.1. The tower height is provided based on EF Johnson's LMR antenna placement and microwave path requirements.
- 1.2. New towers shall be manufactured as a self-supporting lattice design.
- 1.3. The design shall be based on the minimum wind and ice requirements as specified for Class III structures in TIA -222 Standard current revision.
- 1.4. Each tower and foundation shall be designed for all equipment, appurtenances, ancillary equipment, antenna loading and include 50% future capacity.
- 1.5. All structural steel and hardware shall be galvanized after fabrication in accordance with the appropriate standards.
- 1.6. All tower materials shall be hot dip galvanized after fabrication; with a minimum zinc coating of 2 oz. per sq. ft.
- 1.7. Bolts shall be hot dip galvanized according to American Society for Testing and Materials (ASTM) A-325 or the latest version of this standard.
- 1.8. The make, model, serial number, and height of the tower shall be clearly labeled at the base of the tower.
- 1.9. Tower labeling shall be weatherproof and durable such as a stamped metal plate or equivalent.

2. Waveguide Support

- 2.1. There shall be a ladder-type support system associated with the tower to mount the transmission cables.
 - 2.2. The support system shall accommodate cable or waveguide mounting hardware at the proper intervals.
 - 2.3. The support shall be equipped with precision punched or drilled holes to allow installation of bolt-in hangers.
 - 2.4. The support system shall be sized for 50% growth beyond initial system implementation.
-

- 2.5. The support materials will be of similar construction as other tower materials to appear integral to the structure.
- 2.6. The support shall be designed to meet rigidity specifications similar to the tower.

3. **Waveguide Bridge**

- 3.1. The tower shall be equipped with a waveguide bridge with support posts spaced at intervals compliant to the wind loading specifications, but not more than 10 feet distant.
 - 3.2. There shall be a post(s) placed on the bridge to fully support the load.
 - 3.3. The bridge shall be designed to support all initial antenna transmission lines plus 50% growth capacity.
 - 3.4. The structure shall comply with the tower wind and ice requirements as specified in TIA -222 Standard current revision.
 - 3.5. The Contractor shall furnish and install the waveguide bridge between the tower and equipment shelter.
 - 3.6. The following criteria shall govern the design of the waveguide bridge:
 - 3.6.1. Structurally sturdy to support live and dead loads
 - 3.6.2. Free standing (i.e., not attached to the shelter or tower)
 - 3.6.3. Minimum width of 2 feet in width
 - 3.6.4. Length/height as required by the site specifics
 - 3.6.5. Bridge/ice shield material shall be fabricated from galvanized bar grating or approved equivalent
 - 3.6.6. All components of the waveguide bridge shall be hot-dipped galvanized after fabrication
 - 3.6.7. Posts shall have galvanized caps
 - 3.6.8. Posts shall be set in concrete foundations.
-

- 3.6.9. Each post shall be separately grounded to the site ground system with 1/0 AWG solid bare copper conductor.
- 3.6.10. Waveguide bridge shall be built to interface with the entry ports and the appropriate tower intersecting points.
- 3.6.11. Waveguide Bridge shall be effectively grounded to the external ground bar.

4. **Climbing Equipment**

- 4.1. The tower shall be equipped with an approved climbing ladder and safety device.
 - 4.1.1. The ladder may be integrated into the structural components of the tower.
- 4.2. There should be a climbing safety system compliant with the original manufacturer's specifications.
- 4.3. The equipment shall comply with TIA-222 current revision.

5. **Lighting System & Control**

- 5.1. The Contractor shall supply a lighting system for towers more than 200 feet.
 - 5.2. A lighting system is not required by the FAA for towers under 200 feet. However, the FAA may require the installation of a lighting system due to the proximity of a site to an airport.
 - 5.3. The Contractor shall furnish and install an obstruction lighting system approved by the FAA and compliant with applicable standards.
 - 5.4. The lighting system should include:
 - 5.4.1. Controller
 - 5.4.2. Lamps
 - 5.4.3. Lightning protection
 - 5.4.4. Mounting hardware
 - 5.4.5. Service Cabling and conduit
 - 5.4.6. Conduit drain-breather system
-

- 5.4.7. Wiring
 - 5.4.8. Other material required for complete installation
 - 5.5. The lighting system shall be controlled by a 120-volt AC, single-phase solid-state control unit and power supply. Include battery backup for 8 hours.
 - 5.6. The control unit shall be installed within a NEMA 3R metal cabinet or a NEMA 4X cabinet. The control unit shall be mounted inside the equipment shelter.
 - 5.7. The lights shall be automatically controlled by means of a photoelectric unit. The control unit shall be designed with relays for:
 - 5.7.1. ON-OFF status of lights
 - 5.7.2. Control unit failure
 - 5.7.3. Light failure
 - 5.8. The lighting system shall automatically revert to back-up power source upon loss of primary power
 - 5.8.1. The lighting system shall automatically reset upon power restoration of primary power.
 - 5.9. The controller should include a test switch allowing simulation of daytime and nighttime modes.
 - 5.10. All tower lighting wiring shall be contained within rigid galvanized conduit, junction boxes, and lighting equipment housing.
 - 5.11. Vertical conduit runs shall be adjacent to the waveguide supports tower.
 - 5.12. All levels of lighting shall be clearly visible from any direction of approach to the tower.
 - 5.13. The photoelectric unit shall be installed in a moisture-proof protective metal or high impact plastic housing.
 - 5.14. The photoelectric unit shall be installed on the building in an inconspicuous location and adjusted to attain an unobstructed view of the NNE sky.
-

- 5.15. The photocell shall be mounted such that it is not affected by artificial light.
 - 5.16. Photocell wiring shall be installed entirely within rigid galvanized conduit.
 - 5.17. Ice shields shall be installed for all lighting system fixtures except for the topmost light.
 - 5.18. The controller case shall be grounded to the equipment shelter building ground with #4 AWG or larger copper wire.
-

22039 Public Safety Radio Network
New Generator Specifications

The Contractor shall supply a new site generator for the site. Scope of Work. Generator specifications include the following:

1. Power and Electric Requirements

1.1. Fuel: Liquid Propane

1.1.1. Natural gas or diesel may be provided with approval from the County

1.1.2. Output: 40 kW (minimum, and sized for the proposed system)

1.1.3. Phase: Single

1.4. Voltage: 120/240 VAC

1.5. Frequency: 60 Hz

2. Enclosure

The generator enclosure shall be outdoor weather protective and securely attached to a foundation designed to the generator manufacturer's specifications.

3. Muffler Type

The generator muffler shall be of residential critical grade including flexible exhaust section. All remote generators must have spark arrester.

4. Control Panel

4.1. The generator control panel shall be either analog or digital and capable of displaying the following:

4.1.1. Oil Pressure

4.1.2. Coolant temperature

4.1.3. Fuel level (where applicable)

4.1.4. DC battery voltage

4.1.5. Run time hours

4.1.6. Alarm Status

4.2. The generator shall be capable of providing, at a minimum, the following alarm status information:

4.2.1. High or low AC voltage

4.2.2. High or low battery voltage

4.2.3. High or low frequency

- 4.2.4. Low or pre-low oil pressure
- 4.2.5. Low water level
- 4.2.6. Low water temperature
- 4.2.7. High and pre-high engine temperature
- 4.2.8. High, low and critical low fuel levels (where applicable)
- 4.2.9. Over crank
- 4.2.10. Over speed
- 4.2.11. Unit not in "Automatic Mode"

5. Miscellaneous

- 5.1. The generator will be supplied with a block heater, 10 Amp battery charger, and meet NFPA99 and 110 requirements.
- 5.2. The size of the tank and fuel system components shall provide a minimum of 120 hours of run time at full load or 500 gallons, whichever is greater.
- 5.3. The Contractor shall be responsible for generator installation, test, and first fill of all fuel tanks.
- 5.4. Fuel tanks shall be equipped with monitoring devices capable of triggering an alarm contact upon low fuel. The low full threshold shall be programmable. It shall be compatible with Site Boss.
- 5.5. Fuel tanks shall be securely attached to a poured concrete foundation.
- 5.6. Fuel tanks should be in its own enclosure. It must meet US Forrest Service enclosure standards.

6. Automatic Transfer Switch (ATS)

- 6.1. The ATS shall be compatible with the generator set to maintain power system compatibility and local service responsibility for the complete emergency power system.
 - 6.2. The automatic transfer switch shall be electrically installed between the commercial main electrical entry point and the panel with 200-ampere capacity main circuit breaker.
 - 6.3. Wiring must comply with NEC table 373-6(b). The size of the ATS shall be adequate to match the generator and shelter electrical systems.
 - 6.3.1. Controls shall signal the generator to stop after the load retransfers to normal.
 - 6.3.2. A solid-state engine cool down timer, adjustable from 1-30 minutes, shall permit the engine to run unloaded to cool down before shutdown.
 - 6.3.3. Should the utility power fail during this time, the switch will immediately transfer back to the generator.
-

22039 Public Safety Radio Network New Equipment Shelters

New Equipment Shelters

The Contractor shall supply a new equipment shelter for the sites listed in Table 1 of the Scope of Work. Generators shall not be installed in the shelters, which are part of the scope of work.

1. Shelter Size

- 1.1. Minimum shelter size shall be 12' x 20', with a minimum interior height of 9', unless otherwise waived by the County.
- 1.2. Shelter dimensions shall accommodate legacy and new equipment with enough room to expand the usable rack footprint by 40%.

2. Shelter Design and Construction Requirements

- 2.1. The shelter construction shall be concrete or concrete composite.
- 2.2. In addition to all applicable codes and standards, Contractor shall design the shelter to meet or exceed the following structure requirements:
 - 2.2.1. 200 pounds per square foot distributed floor loading while on foundation
 - 2.2.2. 125 pounds per square foot distributed floor loading while lifting
 - 2.2.3. 200 pounds per square foot minimum roof load and a concentrated load of at least 500 pounds per square foot
 - 2.2.4. Minimum wind requirements as specified in TIA 222 Standard current revision
 - 2.2.5. Seismic Design Category [D]
 - 2.2.6. Vents and entryways shall be constructed to deter vandalism
 - 2.2.7. Vents and entryways shall be constructed to prevent the entry of rodents
 - 2.2.8. Waterproof

3. Exterior Finish

The exterior finish of the shelter shall be exposed aggregate.

4. Bullet Resistance

Shelter walls must be capable of stopping 30.06 rifle fires per UL 752 requirements.

5. Fire Rating

Shelter walls must provide a two-hour fire rating.

6. Insulation and Interior Finish

- 6.1. Walls and ceiling must be insulated to a minimum value of R-11.
- 6.2. Interior walls and ceiling must be sheathed with ½ inch white Nu-Poly® or similar board.
- 6.3. Shelter walls must be reinforced as required to support wall mounted equipment.
- 6.4. Floor will be covered with light colored industrial grade vinyl tile floor covering.

7. Exterior Door

- 7.1. The shelter shall be equipped with a 42" x 84" door.
- 7.2. The door shall have a bullet resistance rating that complies with levels 1-4 of UL 752 ballistic standards.
- 7.3. Door, frame and frame components shall be painted or otherwise treated to be rust-proof.
- 7.4. Each door shall as a minimum be equipped with the following hardware and accessories:
 - 7.4.1. A continuous stainless-steel hinge the entire length of the door
 - 7.4.2. Neoprene weather strip
 - 7.4.3. High security locking cylinder latch set
 - 7.4.4. Mortised dead bolt
 - 7.4.5. Anti-pick plate on strike of door to restrict access to the latch and deadbolt
 - 7.4.6. Hydraulic closer
 - 7.4.7. An exterior mounted canopy to protect the door entry shall be designed to support a load of 100 pounds per square foot

8. Power Distribution

Power distribution shall include the following:

- 8.1. One MOV/SAD only lightning arrestor, Type 1
 - 8.2. One MOV lightning arrestor, Type 2
 - 8.3. One 60 Amp enclosed circuit breaker for safety disconnect of TVSS unit
-

- 8.4. One 200 Amp, 10,000 AIC, 120/240 VAC, single phase, 60 Hz, 30 space main breaker, snap-in utility power distribution panel, in a NEMA 1 surface mount enclosure
- 8.5. Circuit breakers for all communications system equipment and customer loads as specified
- 8.6. One 200 Amp, 240 VAC, fused, double pole, single throw safety switch
- 8.7. One 200 Amp, 240 VAC, non-fused, double pole, double throw manual transfer switch
- 8.8. One 200 Amp, four-pin, reversed service exterior power receptacle
- 8.9. Six 20 Amp specification grade duplex receptacles
- 8.10. All wiring shall be installed in surface mounted conduit or NEMA wire ways and be in full compliance with ANSI/NFPA-70 - The National Electric Code, latest version

9. Lighting

- 9.1. Equipment shelter lighting shall be energy efficient and generate low heat levels. Acceptable lighting shall be long-lasting energy efficient technologies, such as light emitting diodes (LED).
 - 9.2. Equipment shelter lighting shall comply with the U.S. defense standard MIL- STD-461E or most current version for low radio frequency interference (RFI) lighting fixtures.
 - 9.3. There should be sufficient interior lighting to provide a level of 540 Lux (50-foot candles at 1 meter (39.4 inches) above the equipment shelter floor. Refer to TIA-569-B or most current version standard for additional information.
 - 9.4. Placement of equipment shelter lighting shall ensure illumination in front of and behind tall equipment racks (within aisle ways; not directly above equipment racks).
 - 9.5. Light fixtures should be hard mounted, if feasible. If hanging fixtures are required, they shall employ earthquake bracing.
 - 9.6. Interior lighting control switches shall be located near the non-hinged side of the entrance door to the equipment shelter. One switch shall control a single lighting fixture, and the second switch shall control the remaining lighting fixtures. Refer to NFPA, NEC 70-2011 (or latest edition) Article 410 - Luminaries, Lamp Holders, and Lamps for additional information.
 - 9.7. Interior emergency backup lighting units shall be installed and activated immediately upon failure of all AC power. The emergency backup lighting shall also be equipped with an illuminated "Exit" sign mounted above the exit door of the equipment shelter indicating exit locations in the equipment shelter during emergency evacuation.
 - 9.8. Exterior lighting shall illuminate points-of-exit and entry into the site compound and the equipment shelter and be located to the side of the entrance way and above door level.
 - 9.9. Each equipment shelter shall have light-emitting diode (LED) exterior lighting fixtures with cutoff housings that limit the beam top to 35° below horizontal, and protection from falling ice.
-

- 9.10. Each shelter shall have a combination photoelectric/motion switch that provides for automatic illumination at sunrise or when motion is detected, and extinguishment of the exterior equipment shelter lights at twilight.
- 9.11. Each exterior light equipped with a combination photoelectric/motion switch shall also have a photoelectric /motion bypass switch installed at the same location as the interior lighting control switches.

10. HVAC

- 10.1. HVAC shall be redundant wall mount air conditioning units, with low ambient and compressor anti-cycle controls, and washable dust filters.
- 10.2. The contractor will ensure HVAC is sized correctly with equipment heat loads and include the following features:
- 10.3. Redundant lead/lag controls allowing approximately equal operating time on each air conditioning unit
- 10.4. Active dehumidification controls that modulate heat and air conditioning operation to control high humidity conditions
- 10.5. One 650 cfm (at 0" of H2O static pressure) exhaust fan system, including motorized intake and exhaust louvers, thermostat, fiberglass hoods, and exhaust insect screen.

11. Site Alarms

Any change in the state of site equipment shall induce an alarmed state that is compatible with Site Boss.

- 11.1. Equipment monitored shall include, but not be limited to the following:
 - 11.2. Surge arrestors
 - 11.3. Transfer switch (normal or bypass state)
 - 11.4. Power fail
 - 11.5. HVAC
 - 11.6. Smoke detector
 - 11.7. Intrusion detection
 - 11.8. High temperature
 - 11.9. Low temperature
 - 11.10. High humidity
-

11.11. UPS/DC Power Plant failure

11.12. UPS state (normal or bypass)

11.13. Generator (including, e.g., generator run, low fuel, high temp, and failure)

11.14. Generator not in auto

11.15. Propane fuel level low

11.16. Tower lighting alarms

11.17. To reduce false alarms, all alarm contacts shall be normally closed when no alarm is present.

12. Grounding

12.1. The Contractor shall follow industry standard best practices for the grounding and bonding of the building, electrical service, tower, cable trays, transmission line entrance portal, and all equipment and other structures, that the County will pre-approve. The Contractor shall provide the standards documents to the County and include these documents in all site documentation.

12.2. The required impedance of the ground system is 5-Ohms or less.

13. Entry Ports

Cable entry ports shall consist of one 12-port/waveguide entry panel with 4-inch sleeves and protective blank covers.

14. Cable Ladder

The Contractor shall supply and install up to 40 feet of 18-inch-wide cable ladder/tray, with prior approval from the County, as the equipment layout may be different on a site-by-site basis.

15. Accessories

The Contractor shall provide the following accessories:

15.1. One portable 10-pound CO2 fire extinguisher

15.2. One handheld emergency eye washing station

15.3. One first aid kit

15.4. One service manual

15.5. One smoke detector

16. Drawings

16.1. The Contractor shall provide two sets of shelter drawings with each shelter.

16.2. The Contractor shall supply typical foundation drawings based on normal soil conditions.

16.3. The Contractor shall supply support calculations for recommended building tie down locations.

17. Generator Plug

17.1. The shelter shall include a wall penetration for exterior weatherproof generator plug, to accommodate the use of a mobile generator.

17.2. The location of the penetration and the type of exterior generator plug that is to be installed in the penetration will be coordinated with the County prior to manufacture of the shelter.

EXECUTED IN 1 ORIGINAL COUNTERPART
BOND NUMBER: GM256851

PAYMENT BOND

KNOW ALL MEN BY THESE PRESENTS:

That the County of Santa Barbara of the State of California (hereinafter referred to as the County) and NORMILE CONSTRUCTION (hereinafter referred to as Principal) have by written agreement dated DECEMBER 29TH, 2025, entered into a contract identified as:

Project Title: County of Santa Barbara
Fire Station 7 Communication Complex
2411 Stanwood Drive, Santa Barbara, CA 93101
Project No. 22039

(Hereinafter referred to as the Contract) and

That, pursuant to law and to said Contract, and before entering upon the performance of said Contract, the principal is required to file with the County a good and sufficient bond to secure the payment of labor and materials claims.

NOW, THEREFORE, said Principal and GREAT MIDWEST INSURANCE COMPANY

as corporate surety (hereinafter referred to as Surety), are held firmly bound unto the County in the amount of \$ 657,420.00, for the payment of which Principal and Surety bind themselves, their heirs, executors, administrators, successors and assigns both jointly and severally. Surety shall be and hereby warrants that it is listed in the Insurance Organizations Authorized by the Insurance Commissioner to Transact Business of Insurance in the State of California, published by the Department of Insurance, State of California or successor publications.

THE CONDITION OF THIS OBLIGATION IS SUCH that if said principal, his or its subcontractors, heirs, executors, administrators, successors, or assigns, shall fail to pay any of the persons named or referred to in Section 9100 of the California Civil Code, or amounts due under Unemployment Insurance Code with respect to work or labor performed by any such claimant, or for any amounts required to be deducted, withheld and paid over to the Employment Development Department from the wages of employees of the Contractor and his subcontractors pursuant to Section 13020 of the Unemployment Insurance Code with respect to such work and labor as required by the California Civil Code, or this bond, then said Surety will pay for the same, in an amount not to exceed the amount hereinafter set forth.

This bond shall insure to the benefit of any and all persons, entities, companies and corporations named or referred to in Section 9100 of the California Civil Code, so as to give a right of action to them or their assign in any suit brought upon this bond.

And the said Surety, for value received, hereby agrees that no change, extension of time, alteration or addition to the terms of the Contract, or to the work to be performed thereunder, or the Specifications accompanying the same, shall in anywise affect its obligations on this bond, and it does hereby waive notice of any such change, extension of time, alteration or addition to the terms of the Contract or to the Specifications.

In the event suit is brought upon this Bond by County and judgment is recovered, Surety shall pay all costs incurred by the County in such suit, including a reasonable attorney's fee to be fixed by the court.

Death, illness, disability or disqualification of the Principal shall not relieve Surety of its obligations hereunder.

NORMILE CONSTRUCTION
Principal

By: 

DATED: FEBRUARY 13TH, 2026

GREAT MIDWEST INSURANCE COMPANY
Surety

Signature of Attorney-in-fact

BRITTON CHRISTIANSEN, ATTORNEY-IN-FACT

800 GESSNER #600
Address

HOUSTON, TX 77024
City, State & Zip Code

Surety's Agent for Service of Process (located within the State of California):

C&D BONDING & INSURANCE SERVICES
Name of Agent

534 E. BADILLO ST.
Address

COVINA, CA 91723
City, State & Zip Code

626-859-1000
Telephone Number

626-859-1001
FAX Number

NOTE: Signature of those executing for Surety must be properly acknowledged.

POWER OF ATTORNEY

Great Midwest Insurance Company

KNOW ALL MEN BY THESE PRESENTS, that GREAT MIDWEST INSURANCE COMPANY, a Texas Corporation, with its principal office in Houston, TX, does hereby constitute and appoint: Philip E. Vega, Kevin Vega, Britton Christiansen

its true and lawful Attorney(s)-In-Fact to make, execute, seal and deliver for, and on its behalf as surety, any and all bonds, undertakings or other writings obligatory in nature of a bond.

This authority is made under and by the authority of a resolution which was passed by the Board of Directors of GREAT MIDWEST INSURANCE COMPANY, on the 1st day of April, 2025 as follows:

Resolved, that the President, or any officer, be and hereby is, authorized to appoint and empower any representative of the Company or other person or persons as Attorney-In-Fact to execute on behalf of the Company any bonds, undertakings, policies, contracts of indemnity or other writings obligatory in nature of a bond not to exceed One-Hundred Million dollars (\$100,000,000.00), which the Company might execute through its duly elected officers, and affix the seal of the Company thereto. Any said execution of such documents by an Attorney-In-Fact shall be as binding upon the Company as if they had been duly executed and acknowledged by the regularly elected officers of the Company. Any Attorney-In-Fact, so appointed, may be removed in the Company's sole discretion and the authority so granted may be revoked as specified in the Power of Attorney.

Resolved, that the signature of the President and the seal of the Company may be affixed by electronic mail on any power of attorney granted, and the signature of the Secretary, and the seal of the Company may be affixed by electronic mail to any certificate of any such power and any such power or certificate bearing such electronic signature and seal shall be valid and binding on the Company. Any such power so executed and sealed and certificate so executed and sealed shall, with respect to any bond of undertaking to which it is attached, continue to be valid and binding on the Company.

IN WITNESS THEREOF, GREAT MIDWEST INSURANCE COMPANY, has caused this instrument to be signed by its President, and its Corporate Seal to be affixed this 8th day of April, 2025.



GREAT MIDWEST INSURANCE COMPANY

BY Mark W. Haushill
Mark W. Haushill
President

ACKNOWLEDGEMENT

On this 8th day of April 2025, before me, personally came Mark W. Haushill to me known, who being duly sworn, did depose and say that he is the President of GREAT MIDWEST INSURANCE COMPANY, the corporation described in and which executed the above instrument; that he executed said instrument on behalf of the corporation by authority of his office under the By-laws of said corporation.

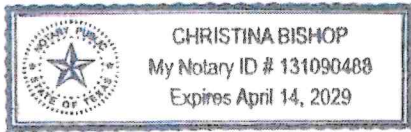

BY Christina Bishop
Christina Bishop
Notary Public

CERTIFICATE

I, the undersigned, Secretary of GREAT MIDWEST INSURANCE COMPANY, A Texas Insurance Company, DO HEREBY CERTIFY that the original Power of Attorney of which the foregoing is a true and correct copy, is in full force and effect and has not been revoked and the resolutions as set forth are now in force.

Signed and Sealed at Houston, TX this 13th Day of February 2026.



BY Patricia Ryan
Patricia Ryan
Secretary

WARNING: Any person who knowingly and with intent to defraud any insurance company or other person, files and application for insurance of claim containing any materially false information, or conceals for the purpose of misleading, information concerning any fact material thereto, commits a fraudulent insurance act, which is a crime and subjects such person to criminal and civil penalties.

CALIFORNIA ALL-PURPOSE ACKNOWLEDGMENT

CIVIL CODE § 1189

A notary public or other officer completing this certificate verifies only the identity of the individual who signed the document to which this certificate is attached, and not the truthfulness, accuracy, or validity of that document.

State of California)
County of SAN LUIS OBISPO)
On FEB 13 2026 before me, McKENZIE SALAZAR, NOTARY PUBLIC
Date Here Insert Name and Title of the Officer
personally appeared BRITTON CHRISTIANSEN
Name(s) of Signer(s)

who proved to me on the basis of satisfactory evidence to be the person(s) whose name(s) is/are subscribed to the within instrument and acknowledged to me that he/she/they executed the same in his/her/their authorized capacity(ies), and that by his/her/their signature(s) on the instrument the person(s), or the entity upon behalf of which the person(s) acted, executed the instrument.

I certify under PENALTY OF PERJURY under the laws of the State of California that the foregoing paragraph is true and correct.

WITNESS my hand and official seal.



Signature *M Salazar*
Signature of Notary Public

Place Notary Seal Above

OPTIONAL

Though this section is optional, completing this information can deter alteration of the document or fraudulent reattachment of this form to an unintended document.

Description of Attached Document

Title or Type of Document: _____ Document Date: _____
Number of Pages: _____ Signer(s) Other Than Named Above: _____

Capacity(ies) Claimed by Signer(s)

Signer's Name: _____
 Corporate Officer — Title(s): _____
 Partner — Limited General
 Individual Attorney in Fact
 Trustee Guardian or Conservator
 Other: _____
Signer Is Representing: _____

Signer's Name: _____
 Corporate Officer — Title(s): _____
 Partner — Limited General
 Individual Attorney in Fact
 Trustee Guardian or Conservator
 Other: _____
Signer Is Representing: _____

In the event suit is brought upon this Bond by County and judgment is recovered, Surety shall pay all costs incurred by the County in such suit, including a reasonable attorney's fee to be fixed by the court.

Death, illness, disability or disqualification of the Principal shall not relieve Surety of its obligations hereunder.

NORMILE CONSTRUCTION

Principal

By: 

MIDWEST INSURANCE COMPANY

Surety

Signature of Attorney-in-fact

DATED: FEBRUARY 13TH, 2026

BRITTON CHRISTIANSEN, ATTORNEY-in-FACT

800 GESSNER #600
Address

HOUSTON, TX 77024
City, State & Zip Code

Surety's Agent for Service of Process (located within the State of California):

C&D BONDING & INSURANCE SERVICES
Name of Agent

534 E. BADILLO ST.
Address

COVINA, CA 91723
City, State & Zip Code

626-859-1000
Telephone Number

626-859-1001
FAX Number

NOTE: Signature of those executing for Surety must be properly acknowledged.

POWER OF ATTORNEY

Great Midwest Insurance Company

KNOW ALL MEN BY THESE PRESENTS, that GREAT MIDWEST INSURANCE COMPANY, a Texas Corporation, with its principal office in Houston, TX, does hereby constitute and appoint: Philip E. Vega, Kevin Vega, Britton Christiansen

its true and lawful Attorney(s)-In-Fact to make, execute, seal and deliver for, and on its behalf as surety, any and all bonds, undertakings or other writings obligatory in nature of a bond.

This authority is made under and by the authority of a resolution which was passed by the Board of Directors of GREAT MIDWEST INSURANCE COMPANY, on the 1st day of April, 2025 as follows:

Resolved, that the President, or any officer, be and hereby is, authorized to appoint and empower any representative of the Company or other person or persons as Attorney-In-Fact to execute on behalf of the Company any bonds, undertakings, policies, contracts of indemnity or other writings obligatory in nature of a bond not to exceed One-Hundred Million dollars (\$100,000,000.00), which the Company might execute through its duly elected officers, and affix the seal of the Company thereto. Any said execution of such documents by an Attorney-In-Fact shall be as binding upon the Company as if they had been duly executed and acknowledged by the regularly elected officers of the Company. Any Attorney-In-Fact, so appointed, may be removed in the Company's sole discretion and the authority so granted may be revoked as specified in the Power of Attorney.

Resolved, that the signature of the President and the seal of the Company may be affixed by electronic mail on any power of attorney granted, and the signature of the Secretary, and the seal of the Company may be affixed by electronic mail to any certificate of any such power and any such power or certificate bearing such electronic signature and seal shall be valid and binding on the Company. Any such power so executed and sealed and certificate so executed and sealed shall, with respect to any bond of undertaking to which it is attached, continue to be valid and binding on the Company.

IN WITNESS THEREOF, GREAT MIDWEST INSURANCE COMPANY, has caused this instrument to be signed by its President, and its Corporate Seal to be affixed this 8th day of April, 2025.



GREAT MIDWEST INSURANCE COMPANY

BY Mark W. Haushill
Mark W. Haushill
President

ACKNOWLEDGEMENT

On this 8th day of April 2025, before me, personally came Mark W. Haushill to me known, who being duly sworn, did depose and say that he is the President of GREAT MIDWEST INSURANCE COMPANY, the corporation described in and which executed the above instrument; that he executed said instrument on behalf of the corporation by authority of his office under the By-laws of said corporation.

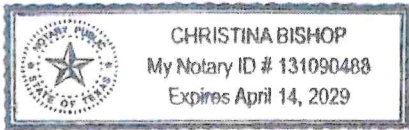

BY Christina Bishop
Christina Bishop
Notary Public

CERTIFICATE

I, the undersigned, Secretary of GREAT MIDWEST INSURANCE COMPANY, A Texas Insurance Company, DO HEREBY CERTIFY that the original Power of Attorney of which the foregoing is a true and correct copy, is in full force and effect and has not been revoked and the resolutions as set forth are now in force.

Signed and Sealed at Houston, TX this 13th Day of February 2026



BY Patricia Ryan
Patricia Ryan
Secretary

WARNING: Any person who knowingly and with intent to defraud any insurance company or other person, files and application for insurance of claim containing any materially false information, or conceals for the purpose of misleading, information concerning any fact material thereto, commits a fraudulent insurance act, which is a crime and subjects such person to criminal and civil penalties.

CALIFORNIA ALL-PURPOSE ACKNOWLEDGMENT

CIVIL CODE § 1189

A notary public or other officer completing this certificate verifies only the identity of the individual who signed the document to which this certificate is attached, and not the truthfulness, accuracy, or validity of that document.

State of California)
County of SAN LUIS OBISPO)
On FEB 13 2026 before me, McKENZIE SALAZAR, NOTARY PUBLIC
Date Here Insert Name and Title of the Officer
personally appeared BRITTON CHRISTIANSEN
Name(s) of Signer(s)

who proved to me on the basis of satisfactory evidence to be the person(s) whose name(s) is/are subscribed to the within instrument and acknowledged to me that he/she/they executed the same in his/her/their authorized capacity(ies), and that by his/her/their signature(s) on the instrument the person(s), or the entity upon behalf of which the person(s) acted, executed the instrument.

I certify under PENALTY OF PERJURY under the laws of the State of California that the foregoing paragraph is true and correct.

WITNESS my hand and official seal.



Signature *msalazar*
Signature of Notary Public

Place Notary Seal Above

OPTIONAL

Though this section is optional, completing this information can deter alteration of the document or fraudulent reattachment of this form to an unintended document.

Description of Attached Document

Title or Type of Document: _____ Document Date: _____
Number of Pages: _____ Signer(s) Other Than Named Above: _____

Capacity(ies) Claimed by Signer(s)

Signer's Name: _____
 Corporate Officer — Title(s): _____
 Partner — Limited General
 Individual Attorney in Fact
 Trustee Guardian or Conservator
 Other: _____
Signer Is Representing: _____

Signer's Name: _____
 Corporate Officer — Title(s): _____
 Partner — Limited General
 Individual Attorney in Fact
 Trustee Guardian or Conservator
 Other: _____
Signer Is Representing: _____

BID BOND

KNOW ALL BY THESE PRESENTS, That we, NORMILE CONSTRUCTION, INC.

of 8795 MORRO RD. ATASCADERO, CA 93422 (hereinafter called the Principal),

as Principal, and GREAT MIDWEST INSURANCE COMPANY

(hereinafter called the Surety), as Surety are held and firmly bound unto COUNTY OF SANTA BARBARA

(hereinafter called the Obligee) in the penal sum of TEN PERCENT OF AMOUNT BID

Dollars (\$ 10%)

for the payment of which the Principal and the Surety bind themselves, their heirs, executors, administrators, successors and assigns, jointly and severally, firmly by these presents.

THE CONDITION OF THIS OBLIGATION IS SUCH, That WHEREAS, the Principal has submitted or is about to submit a proposal to the Obligee on a contract for FIRE STATION 7 COMMUNICATION COMPLEX

NOW, THEREFORE, If the said Contract be timely awarded to the Principal and the Principal shall, within such time as may be specified, enter into the Contract in writing, and give bond, if bond is required, with surety acceptable to the Obligee for the faithful performance of the said Contract, then this obligation shall be void; otherwise to remain in full force and effect.

Signed and sealed this 15TH day of DECEMBER, 2025.

Witness

NORMILE CONSTRUCTION, INC. (Seal)
Principal
[Signature]
Title

Witness

GREAT MIDWEST INSURANCE COMPANY
By [Signature]
KEVIN VEGA, Attorney-in-Fact

POWER OF ATTORNEY

Great Midwest Insurance Company

KNOW ALL MEN BY THESE PRESENTS, that GREAT MIDWEST INSURANCE COMPANY, a Texas Corporation, with its principal office in Houston, TX, does hereby constitute and appoint: Philip E. Vega, Kevin Vega, Britton Christiansen

its true and lawful Attorney(s)-In-Fact to make, execute, seal and deliver for, and on its behalf as surety, any and all bonds, undertakings or other writings obligatory in nature of a bond.

This authority is made under and by the authority of a resolution which was passed by the Board of Directors of GREAT MIDWEST INSURANCE COMPANY, on the 1st day of April, 2025 as follows:

Resolved, that the President, or any officer, be and hereby is, authorized to appoint and empower any representative of the Company or other person or persons as Attorney-In-Fact to execute on behalf of the Company any bonds, undertakings, policies, contracts of indemnity or other writings obligatory in nature of a bond not to exceed One-Hundred Million dollars (\$100,000,000.00), which the Company might execute through its duly elected officers, and affix the seal of the Company thereto. Any said execution of such documents by an Attorney-In-Fact shall be as binding upon the Company as if they had been duly executed and acknowledged by the regularly elected officers of the Company. Any Attorney-In-Fact, so appointed, may be removed in the Company's sole discretion and the authority so granted may be revoked as specified in the Power of Attorney.

Resolved, that the signature of the President and the seal of the Company may be affixed by electronic mail on any power of attorney granted, and the signature of the Secretary, and the seal of the Company may be affixed by electronic mail to any certificate of any such power and any such power or certificate bearing such electronic signature and seal shall be valid and binding on the Company. Any such power so executed and sealed and certificate so executed and sealed shall, with respect to any bond of undertaking to which it is attached, continue to be valid and binding on the Company.

IN WITNESS THEREOF, GREAT MIDWEST INSURANCE COMPANY, has caused this instrument to be signed by its President, and its Corporate Seal to be affixed this 8th day of April, 2025.



GREAT MIDWEST INSURANCE COMPANY

BY Mark W. Haushill
Mark W. Haushill
President

ACKNOWLEDGEMENT

On this 8th day of April 2025, before me, personally came Mark W. Haushill to me known, who being duly sworn, did depose and say that he is the President of GREAT MIDWEST INSURANCE COMPANY, the corporation described in and which executed the above instrument; that he executed said instrument on behalf of the corporation by authority of his office under the By-laws of said corporation.

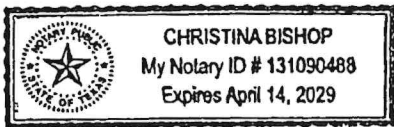

BY Christina Bishop
Christina Bishop
Notary Public

CERTIFICATE

I, the undersigned, Secretary of GREAT MIDWEST INSURANCE COMPANY, A Texas Insurance Company, DO HEREBY CERTIFY that the original Power of Attorney of which the foregoing is a true and correct copy, is in full force and effect and has not been revoked and the resolutions as set forth are now in force.

Signed and Sealed at Houston, TX this 15th Day of December 2025.



BY Patricia Ryan
Patricia Ryan
Secretary

"WARNING: Any person who knowingly and with intent to defraud any insurance company or other person, files and application for insurance of claim containing any materially false information, or conceals for the purpose of misleading, information concerning any fact material thereto, commits a fraudulent insurance act, which is a crime and subjects such person to criminal and civil penalties.

CALIFORNIA ALL-PURPOSE ACKNOWLEDGMENT

A notary public or other officer completing this certificate verifies only the identity of the individual who signed the document to which this certificate is attached, and not the truthfulness, accuracy, or validity of that document.

State of California }
} ss.
County of LOS ANGELES }

On December 15th, 2025 before me, Philip Vega, Notary Public
Here Insert Name and Title of the Officer

personally appeared Kevin Vega, Attorney-in-Fact
Name(s) of Signer(s)

who proved to me on the basis of satisfactory evidence to be the person(s) whose name(s) is/are subscribed to the within instrument and acknowledged to me that he/she/they executed the same in his/her/their authorized capacity(ies), and that by his/her/their signature(s) on the instrument the person(s), or the entity upon behalf of which the person(s) acted, executed the instrument.

I certify under PENALTY OF PERJURY under the laws of the State of California that the foregoing paragraph is true and correct.

WITNESS my hand and official seal.

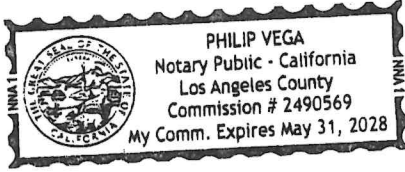

Signature:

Signature of Notary Public

Place Notary Seal Above

OPTIONAL

Though the information below is not required by law, it may prove valuable to persons relying on the document and could prevent fraudulent removal and reattachment of this form to another document.

Description of Attached Document

Title of Type of Document:
Document Date: Number of Pages:
Signer(s) Other Than Named Above:

Capacity(ies) Claimed by Signer(s)

Signer's Name:
Individual
Corporate Officer Title(s):
Partner - Limited General
Attorney in Fact
Trustee
Guardian or Conservator
Other:

Right Thumbprint of Signer
Top of thumb here

Signer's Name:
Individual
Corporate Officer Title(s):
Partner - Limited General
Attorney in Fact
Trustee
Guardian or Conservator
Other:

Right Thumbprint of Signer
Top of thumb here

Signer is Representing:

Signer is Representing:

BIDDER'S BOND

KNOW ALL MEN BY THESE PRESENTS:

That we, Mormik Construction Inc as Principal, and Great Midwest Insurance Company as Surety (hereinafter referred to as Surety), are held firmly bound unto the County of Santa Barbara, State of California (hereinafter called "Owner") in the penal sum of Ten Percent (10%) of the total aggregate amount of the bid of the Principal above named, submitted by said Principal to Owner for the work described below, for the payment of which sum in lawful money of the United States, well and truly to be made, we bind ourselves, our heirs, executors, administrators, and successors, jointly and severally, firmly by these presents. Surety shall be and hereby warrants that it is listed in the Insurance Organizations Authorized by the Insurance Commissioner to Transact Business of Insurance in the State of California, published by the Department of Insurance, State of California or successor publications. In no case shall the liability of the Surety hereunder exceed the sum of Ten percent of amount bid DOLLARS (\$ 10%). The condition of this obligation is such that a bid to Owner for certain construction specifically described as follows:

**COUNTY OF SANTA BARBARA
Fires Station 7 Communication Complex
2411 Stanwood Drive, Santa Barbara, CA 91301
Project No. 22039**

for which bids are due on Monday December 22, 2025 at 3:00 PM has been submitted by Principal to Owner.

NOW, THEREFORE, if the aforesaid Principal shall not withdraw said bid within the period therein after the opening of the same, or, if no period be specified within sixty (60) days after said opening and shall within the period specified therefore, or, if no period be specified, within eight (8) days after the prescribed forms are presented to him for signature, enter into a written Contract with Owner, in the prescribed form, in accordance with the bid as accepted, and file the two Bonds with Owner, one to guarantee faithful performance and the other to guarantee payment for labor and materials, as required by law, then this obligation shall be null and void; otherwise, it shall remain in full force, virtue and affect.

Said Surety, for value received, hereby stipulates and agrees that no change, extension of time, alteration or addition to the terms of said Contract or to the work to be performed thereunder or the Specifications accompanying the same shall in any manner affects its obligations on this bond, and it does hereby waive notice of any change, extension, alteration, or addition.

It is hereby agreed that any progress payment made after the scheduled completion date will not constitute a waiver of any liquidated damages heretofore agreed upon.

In the event suit is brought upon said Bond by Owner and judgment is recovered, the Surety shall pay all costs incurred by Owner in such suit, including a reasonable attorney's fee to be fixed by the Court.

Death, Bankruptcy, Receivership, Going Out of Business for any reason, or incompetence of the Principal shall not relieve the Surety of its obligations hereunder.

Normile Construction, Inc.
Name of Principal

Dated 11-22-2025

[Signature] (Seal)
Signature of Principal

Great Midwest Insurance Company
Name of Surety

800 Gessner #600
Address

Houston TX 77029
City, State & Zip

Dated _____

Signature of Surety's Attorney-in-fact (Seal)

Surety's Agent for Service of Process (located within the State of California):

Name of Agent

Address

City, State & Zip

Telephone Number

FAX Number

NOTE: Signatures of those executing for Surety MUST be properly acknowledged. This form may be reproduced for transmittal to the Surety for execution and attached to the front of the original Bid Bond Form.

EXHIBIT B

EXHIBIT B

Contractor Proposal

BID FORM

1. Pursuant to and in compliance with your Notice to Bidders and the Contract Documents relating to the construction of:

COUNTY OF SANTA BARBARA
Fires Station 7 Communication Complex
2411 Stanwood Drive, Santa Barbara, CA 91301
Project No. 22039
Bid Due Date: Monday, December 22, 2025, at 3:00 PM

including Addendum No(s). 1, 2, __, __, __, __, __, the undersigned bidder, having become thoroughly familiar with the terms and conditions of the Contract Documents and with local conditions affecting the performance and the costs of the Work at the place where the Work is to be done, hereby proposes and agrees to fully perform the Work within the time stated in and in strict accordance with the Contract Documents (including the furnishing of any and all labor, materials, tools, expendable equipment and utility and transportation services necessary to fully perform the work and complete it in a workmanlike manner) for the total sum of:

2. **BASE BID:**

\$

--	--

 ,

6	5	7
---	---	---

 ,

4	2	0
---	---	---

 .

0	0
---	---

(Place figures in appropriate boxes.)

Estimated number of workdays: 65

3. If the project has additive bid items or additive groups, the lowest responsible bidder will be determined in accordance with Public Contract Code Division II, Part 3, Chapter 1, Section 20103.8, Subdivision (c) and as follows:
 - a. The project funding amount will be disclosed before the first bid is opened.
 - b. The lowest responsible bidder will be determined on the basis of the Total Base Bid plus Total Additive Items or Total Base Bid plus Total Additive Groups, if any.
 - c. In the event that all bids including Total Base Bid plus Total Additive Items or Total Base Bid plus Total Additive Groups exceeds the project funding amount, the lowest bid will be determined on the basis of the Total Base Bid plus those additive items or Total Base Bid plus those additive groups that, when taken in numerical order from the additive list, and added to the Total Base Bid are less than or equal to the funds available.
4. It is understood that Owner reserves the right to reject the proposal and that it shall remain open and not be withdrawn for a period of sixty (60) calendar days from the date prescribed for its opening.
5. Attached hereto and incorporated herein is the complete and entire list of subcontractors to be employed by the undersigned and in the performance of the Work.
6. It is understood and agreed that if written notice of the acceptance of this proposal is mailed or delivered personally to the undersigned bidder within thirty (30) calendar days after the opening of the proposal, or at any time thereafter before it is withdrawn, the undersigned bidder will execute and deliver the Contract Documents to Owner in accordance with the proposal as accepted, and will also furnish and deliver to Owner any Payment Bond required under the provisions of California Civil Code Section 3247 through 3252 and Performance Bond as required under the provisions of the California Government Code and/or California Public Contract Code all within fourteen (14) calendar days after personal delivery or deposit in the mails, as the case may be, of the notifications of award. The

work under the contract shall be commenced by the undersigned bidder on the date stated in COUNTY'S written Notice to Proceed and shall be completed within **365 calendar** days thereafter.

- 7. Notice of acceptance or request for additional information may be addressed to the undersigned bidder at the business address set forth below.
- 8. The bid, contract or other submittal of the CONTRACTOR identified below in connection with the foregoing project is not made in the interest of or on behalf of any undisclosed person, partnership, company, association, organization, or corporation; and that the bid is genuine, and not collusive or sham; that the undersigned bidder has not directly or indirectly induced or solicited any other bidder to put in a false or sham bid and has not directly or indirectly colluded, conspired, connived or agreed with any bidder or anyone else to put in a sham bid, or to refrain from bidding; that the undersigned bidder has not directly or indirectly sought by agreement, communication or conference with anyone to fix his bid price or the bid price of any other bidder or to fix any overhead, profit or cost element of such bid price or of that of any other bidder or to secure any advantage against the COUNTY of Santa Barbara of anyone interested in the proposed contract; or all statements contained in this proposal are true; and that the undersigned bidder has not directly or indirectly, submitted his or her bid price or any breakdown thereof, or the contents thereof, or divulged information or data relative thereto, or paid, and will not pay any fee to any corporation, partnership, company association, organization, Bid Depository or to any member or agent thereof to effectuate a collusive or sham bid. I declare under the penalty of perjury under the laws of the State of California that the foregoing is true and correct.
- 9. Wherever in this proposal an amount is stated in both words and figures, in case of discrepancy between words and figures the words shall prevail; if all or any portion of the proposal is required to be given in unit prices and totals and a discrepancy existing between any such unit prices and totals so given, the unit prices shall prevail.
- 10. In accordance with the provisions of Sections 1860 and 1861 of the California Labor Code, every CONTRACTOR will be required to secure the payment of compensation of his or her employees. Each CONTRACTOR to whom a public works contract is awarded shall sign the following certification prior to performing the work of the contract: "I am aware of the provisions of Section 3700 of the Labor Code which requires every employer to be insured against liability for worker's compensation or to undertake self-insurance in accordance with the provisions of that code, and I will comply with such provisions before commencing the performance of the work of this contract."
- 11. Protests of any bid(s) received must be in writing, must specify all grounds for the protest, and must be filed within ten working days after the opening of bids.

CONTRACTOR

Normile Construction Inc.
Company

IRS No.: 00-1657412

8795 Motto Rd.
Street Address

License Classification(s): B

Atascadero, Ca 93422
City

Phone Number: 805-460-6022

BY: 
Signature

Rusty Shepherd / Construction Manager
Printed Name, Title

DESIGNATION OF SUBCONTRACTORS

The bidder agrees if this proposal is accepted, that he will contract with the County of Santa Barbara to do all work and furnish all labor, materials, machinery, tools and apparatus necessary to completely perform said Contracts in the manner and time prescribed by said Contract.

COUNTY OF SANTA BARBARA
Fires Station 7 Communication Complex
2411 Stanwood Drive, Santa Barbara, CA 91301
Project No. 22039

Bid Due Date: Monday, December 22, 2025 at 3:00 PM

In compliance with the provisions of Section 4100-4107 of the Public Contract Code of the State of California, and any amendments, thereof, the undersigned bidder has set forth below the name and location of the place of business of each subcontractor who will perform work or labor or render service to the undersigned in or about the construction of the work to be performed. That portion of the work which will be done by each subcontractor for each subcontract in excess of one-half of one percent of the undersigned's total aggregate bid shall be listed.

DIVISION OF WORK	SUBCONTRACTOR	LIC NO.	LOCATION
Engineering	Streamline Engineering	54469	Loomis, Ca
Electrical	Dynamic Electric	CI0-458336	Atascadero, Ca

COMPANY: Normie Construction Inc BY: 
Bidder's Signature

NOTE: This form may be reproduced and attached behind this page to list more Subcontractors.

NONCOLLUSION AFFIDAVIT

In accordance with Public Contract Code § 7106. Rusty Shepherd
(Bidder's full name)

being first duly sworn, deposes and says that he or she is Construction Manager
(Bidder's title)

of Normile Construction Inc.
(Company's name)

the party making the foregoing Bid, that the Bid is not made in the interest of, or on behalf of, any undisclosed person, partnership, company, association, organization, or corporation; that the Bid is genuine and not collusive or sham; that the Bidder has not directly or indirectly induced or solicited any other bidder to put in a false or sham Bid, and has not directly or indirectly colluded, conspired, connived, or agreed with any Bidder or anyone else to put in a sham Bid, or that anyone shall refrain from bidding; that the Bidder has not in any manner, directly or indirectly, sought by agreement, communication, or conference with anyone to fix the Bid price of the Bidder or any other Bidder, or to fix any overhead, profit, or cost element of the Bid price, or of that of any other Bidder, or to secure any advantage against the public body awarding the contract of anyone interested in the proposed Contract; that all statements contained in the Bid are true; and further, that the Bidder has not, directly or indirectly, submitted his or her bid price or any breakdown thereof, or the contents thereof, or divulged information or data relative thereto, to any corporation, partnership, company, association, organization, bid depository, or to any member or agent thereof to effectuate a collusive or sham Bid and has not paid, and will not pay, any person or entity for such purpose.

Any person executing this declaration on behalf of a bidder that is a corporation, partnership, joint venture, limited liability company, limited liability partnership, or any other entity, hereby represents that he or she has full power to execute, and does execute, this declaration on behalf of the bidder.

I declare under penalty of perjury under the laws of the State of California that the foregoing is true and correct.

SIGNATURE BLOCK <i>(Signature Block must be completed in ink & changes must be initialed.)</i>	
Bidder's Signature: <u><i>Rusty Shepherd</i></u>	Date: <u>12/19/2025</u>
Bidder's Name & Title (Print): <u>Rusty Shepherd / Construction Manager</u>	
At CITY: <u>Atascadero</u>	STATE: <u>CA</u>

CERTIFICATE OF COMPLIANCE

This is to certify that all requirements for insurance of subcontractors as specified for this project will be met.

12-22-2025
Dated

Signature of Principal

Chad Normile owner
Printed Name, Title of Principal

Normile Construction Inc.
Company

8795 Morro Rd.
Address

Atascadero, Ca 93422
City, State & Zip

BIDDER'S STATEMENTS

REGARDING INSURANCE COVERAGE:

Bidder hereby certifies that he has reviewed the insurance coverage requirements specified in the Contract Forms. Should he be awarded the contract for the work, Bidder further certifies that he can meet all the Contract Specification requirements for insurance including insurance coverage of his subcontractors.

REGARDING TITLE 13 OF THE CA CODE OF REGULATIONS, BIDDER'S FLEET:

Bidder must provide to the County, prior to executing the Contract, a true and correct copy of each valid Certificate of Reported Compliance, as described in section 2449(n) of Title 13 of the California Code of Regulations, for Bidder's fleet, and for each fleet of each subcontractor listed in Bidder's Bid, of vehicles subject to 13 CCR section 2449 that may be used in performance of the Contract.

REGARDING PUBLIC CONTRACT CODE SECTION 10232:

In accordance with Public Contract Code Section 10232, the Contractor hereby states, under penalty of perjury, that no more than one final unappealable finding of contempt of court by a Federal Court has been issued against the Contractor within the immediately preceding two year period because of the Contractor's failure to comply with an order of a Federal Court which orders the Contractor to comply with an order of the National Labor Relations Board.

REGARDING PUBLIC CONTRACT CODE SECTION 10162:

In accordance with Public Contract Code Section 10162, the Bidder shall complete, under penalty of perjury, the following questionnaire:

Has the bidder, any officer of the bidder, or any employee of the bidder who has proprietary interest in the bidder, ever been disqualified, removed, or otherwise prevented from bidding on, or completing, a federal, state, or local government project because of a violation of law or safety regulation?

Yes _____

No X

(If the answer is yes, explain the circumstances on a separate sheet of paper and attach to proposal)

12-22-2025
Date

Signature of Principal

Chad Normile owner
Printed Name, Title of Principal

Normile Construction Inc.
Company

8795 Morro Rd.
Address

Atascadero, Ca 93422
City, State & Zip

ANTI-FRAUD CERTIFICATION

COUNTY OF SANTA BARBARA
Fires Station 7 Communication Complex
2411 Stanwood Drive, Santa Barbara, CA 91301
Project No. 22039
Bid Due Date: Monday December 22,2025

In accordance with Public Contract Code Section 10285.1 (Chapter 376, Stats. 1985), the bidder hereby declares under penalty of perjury that the bidder **has** __, **has not** __, been convicted within the preceding three years of any offenses referred to in that section, including any charge of fraud, bribery, collusion, conspiracy, or any other act in violation of any state or federal antitrust law in connection with the bidding upon award of, or performance of, any public works contract, as defined in Public Contract Code Section 1101, with any public entity, as defined in Public Contract Code Section 1100, including the Regents of the University of California or Trustees of the California State University.

The term "bidder" is understood to include any partner, member, officer, director, responsible managing officer, or responsible managing employee thereof, as referred to in Section 10285.1.

NOTE: The bidder must place a check mark after "has" or "has not" in one of the blank spaces provided.

<u>12-22-2025</u> Date	 Signature of Principal
	<u>Chad Normile owner</u> Printed Name, Title of Principal
	<u>Normile Construction Inc.</u> Company
	<u>8795 Motro Rd.</u> Address
	<u>Atascadero, Ca 93422</u> City, State & Zip

BID BOND

KNOW ALL BY THESE PRESENTS, That we, NORMILE CONSTRUCTION, INC.

of 8795 MORRO RD. ATASCADERO, CA 93422 (hereinafter called the Principal),

as Principal, and GREAT MIDWEST INSURANCE COMPANY

(hereinafter called the Surety), as Surety are held and firmly bound unto COUNTY OF SANTA BARBARA

(hereinafter called the Obligee) in the penal sum of TEN PERCENT OF AMOUNT BID

Dollars (\$ 10%)

for the payment of which the Principal and the Surety bind themselves, their heirs, executors, administrators, successors and assigns, jointly and severally, firmly by these presents.

THE CONDITION OF THIS OBLIGATION IS SUCH, That WHEREAS, the Principal has submitted or is about to submit a proposal to the Obligee on a contract for FIRE STATION 7 COMMUNICATION COMPLEX

NOW, THEREFORE, If the said Contract be timely awarded to the Principal and the Principal shall, within such time as may be specified, enter into the Contract in writing, and give bond, if bond is required, with surety acceptable to the Obligee for the faithful performance of the said Contract, then this obligation shall be void; otherwise to remain in full force and effect.

Signed and sealed this 15TH day of DECEMBER, 2025.

Witness

NORMILE CONSTRUCTION, INC. (Seal)
Principal
[Signature]
Title

Witness

GREAT MIDWEST INSURANCE COMPANY
By [Signature]
KEVIN VEGA, Attorney-in-Fact

POWER OF ATTORNEY

Great Midwest Insurance Company

KNOW ALL MEN BY THESE PRESENTS, that GREAT MIDWEST INSURANCE COMPANY, a Texas Corporation, with its principal office in Houston, TX, does hereby constitute and appoint: Philip E. Vega, Kevin Vega, Britton Christiansen

its true and lawful Attorney(s)-In-Fact to make, execute, seal and deliver for, and on its behalf as surety, any and all bonds, undertakings or other writings obligatory in nature of a bond.

This authority is made under and by the authority of a resolution which was passed by the Board of Directors of GREAT MIDWEST INSURANCE COMPANY, on the 1st day of April, 2025 as follows:

Resolved, that the President, or any officer, be and hereby is, authorized to appoint and empower any representative of the Company or other person or persons as Attorney-In-Fact to execute on behalf of the Company any bonds, undertakings, policies, contracts of indemnity or other writings obligatory in nature of a bond not to exceed One-Hundred Million dollars (\$100,000,000.00), which the Company might execute through its duly elected officers, and affix the seal of the Company thereto. Any said execution of such documents by an Attorney-In-Fact shall be as binding upon the Company as if they had been duly executed and acknowledged by the regularly elected officers of the Company. Any Attorney-In-Fact, so appointed, may be removed in the Company's sole discretion and the authority so granted may be revoked as specified in the Power of Attorney.

Resolved, that the signature of the President and the seal of the Company may be affixed by electronic mail on any power of attorney granted, and the signature of the Secretary, and the seal of the Company may be affixed by electronic mail to any certificate of any such power and any such power or certificate bearing such electronic signature and seal shall be valid and binding on the Company. Any such power so executed and sealed and certificate so executed and sealed shall, with respect to any bond of undertaking to which it is attached, continue to be valid and binding on the Company.

IN WITNESS THEREOF, GREAT MIDWEST INSURANCE COMPANY, has caused this instrument to be signed by its President, and its Corporate Seal to be affixed this 8th day of April, 2025.



GREAT MIDWEST INSURANCE COMPANY

BY Mark W. Haushill
Mark W. Haushill
President

ACKNOWLEDGEMENT

On this 8th day of April 2025, before me, personally came Mark W. Haushill to me known, who being duly sworn, did depose and say that he is the President of GREAT MIDWEST INSURANCE COMPANY, the corporation described in and which executed the above instrument; that he executed said instrument on behalf of the corporation by authority of his office under the By-laws of said corporation.

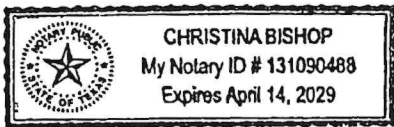

BY Christina Bishop
Christina Bishop
Notary Public

CERTIFICATE

I, the undersigned, Secretary of GREAT MIDWEST INSURANCE COMPANY, A Texas Insurance Company, DO HEREBY CERTIFY that the original Power of Attorney of which the foregoing is a true and correct copy, is in full force and effect and has not been revoked and the resolutions as set forth are now in force.

Signed and Sealed at Houston, TX this 15th Day of December 2025.



BY Patricia Ryan
Patricia Ryan
Secretary

"WARNING: Any person who knowingly and with intent to defraud any insurance company or other person, files and application for insurance of claim containing any materially false information, or conceals for the purpose of misleading, information concerning any fact material thereto, commits a fraudulent insurance act, which is a crime and subjects such person to criminal and civil penalties.

CALIFORNIA ALL-PURPOSE ACKNOWLEDGMENT

A notary public or other officer completing this certificate verifies only the identity of the individual who signed the document to which this certificate is attached, and not the truthfulness, accuracy, or validity of that document.

State of California }
} ss.
County of LOS ANGELES }

On December 15th, 2025 before me, Philip Vega, Notary Public
Here Insert Name and Title of the Officer

personally appeared Kevin Vega, Attorney-in-Fact
Name(s) of Signer(s)

who proved to me on the basis of satisfactory evidence to be the person(s) whose name(s) is/are subscribed to the within instrument and acknowledged to me that he/she/they executed the same in his/her/their authorized capacity(ies), and that by his/her/their signature(s) on the instrument the person(s), or the entity upon behalf of which the person(s) acted, executed the instrument.

I certify under PENALTY OF PERJURY under the laws of the State of California that the foregoing paragraph is true and correct.

WITNESS my hand and official seal.

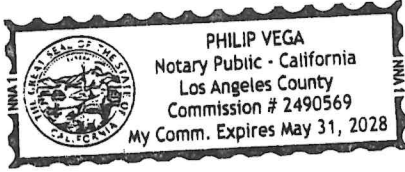

Signature:

Signature of Notary Public

Place Notary Seal Above

OPTIONAL

Though the information below is not required by law, it may prove valuable to persons relying on the document and could prevent fraudulent removal and reattachment of this form to another document.

Description of Attached Document

Title of Type of Document:
Document Date: Number of Pages:
Signer(s) Other Than Named Above:

Capacity(ies) Claimed by Signer(s)

Signer's Name:
Individual
Corporate Officer Title(s):
Partner - Limited General
Attorney in Fact
Trustee
Guardian or Conservator
Other:

Signer's Name:
Individual
Corporate Officer Title(s):
Partner - Limited General
Attorney in Fact
Trustee
Guardian or Conservator
Other:

Right Thumbprint of Signer
Top of thumb here

Right Thumbprint of Signer
Top of thumb here

Signer is Representing:

Signer is Representing:

BIDDER'S BOND

KNOW ALL MEN BY THESE PRESENTS:

That we, Mormik Construction Inc as Principal, and Great Midwest Insurance Company as Surety (hereinafter referred to as Surety), are held firmly bound unto the County of Santa Barbara, State of California (hereinafter called "Owner") in the penal sum of Ten Percent (10%) of the total aggregate amount of the bid of the Principal above named, submitted by said Principal to Owner for the work described below, for the payment of which sum in lawful money of the United States, well and truly to be made, we bind ourselves, our heirs, executors, administrators, and successors, jointly and severally, firmly by these presents. Surety shall be and hereby warrants that it is listed in the Insurance Organizations Authorized by the Insurance Commissioner to Transact Business of Insurance in the State of California, published by the Department of Insurance, State of California or successor publications. In no case shall the liability of the Surety hereunder exceed the sum of Ten percent of amount bid DOLLARS (\$ 10%). The condition of this obligation is such that a bid to Owner for certain construction specifically described as follows:

**COUNTY OF SANTA BARBARA
Fires Station 7 Communication Complex
2411 Stanwood Drive, Santa Barbara, CA 91301
Project No. 22039**

for which bids are due on Monday December 22, 2025 at 3:00 PM has been submitted by Principal to Owner.

NOW, THEREFORE, if the aforesaid Principal shall not withdraw said bid within the period therein after the opening of the same, or, if no period be specified within sixty (60) days after said opening and shall within the period specified therefore, or, if no period be specified, within eight (8) days after the prescribed forms are presented to him for signature, enter into a written Contract with Owner, in the prescribed form, in accordance with the bid as accepted, and file the two Bonds with Owner, one to guarantee faithful performance and the other to guarantee payment for labor and materials, as required by law, then this obligation shall be null and void; otherwise, it shall remain in full force, virtue and affect.

Said Surety, for value received, hereby stipulates and agrees that no change, extension of time, alteration or addition to the terms of said Contract or to the work to be performed thereunder or the Specifications accompanying the same shall in any manner affects its obligations on this bond, and it does hereby waive notice of any change, extension, alteration, or addition.

It is hereby agreed that any progress payment made after the scheduled completion date will not constitute a waiver of any liquidated damages heretofore agreed upon.

In the event suit is brought upon said Bond by Owner and judgment is recovered, the Surety shall pay all costs incurred by Owner in such suit, including a reasonable attorney's fee to be fixed by the Court.

Death, Bankruptcy, Receivership, Going Out of Business for any reason, or incompetence of the Principal shall not relieve the Surety of its obligations hereunder.

Normile Construction, Inc.
Name of Principal

Dated 11-22-2025

[Signature] (Seal)
Signature of Principal

Great Midwest Insurance Company
Name of Surety

800 Gessner #600
Address

Houston TX 77029
City, State & Zip

Dated _____

Signature of Surety's Attorney-in-fact (Seal)

Surety's Agent for Service of Process (located within the State of California):

Name of Agent

Address

City, State & Zip

Telephone Number

FAX Number

NOTE: Signatures of those executing for Surety MUST be properly acknowledged. This form may be reproduced for transmittal to the Surety for execution and attached to the front of the original Bid Bond Form.

EXHIBIT C

EXHIBIT C

Certificate of Transmittal

Certificate of Insurance



CERTIFICATE OF INSURANCE TRANSMITTAL FORM

FOR THE FOLLOWING DESCRIBED PROJECT:

County of Santa Barbara
Fire Station 7 Communication Complex
2411 Stanwood Drive, Santa Barbara, CA 93103
Project No. 22039

CONTRACTOR:

Nonmike Construction Inc.
Name

2815 Ferro Canal Rd
Address

Atascadero CA 93422
City, State & Zip Code

The successful bidder shall furnish satisfactory proof of the maintenance of adequate Worker's Compensation Insurance, and the maintenance of Comprehensive General and Automobile Liability Insurance in the amount of not less than \$1,000,000 per occurrence and \$2,000,000 in the aggregate. The County of Santa Barbara (COUNTY), its officers, employees, and agents shall be named as additional insured on all certificates. A copy of the endorsement evidencing that the County has been added to the policy must be attached to the certificate of insurance. Said policy or policies shall provide that the COUNTY shall be given thirty (30) days written notice prior to cancellation or expiration of the policy or reduction in coverage. Refer to section 5.18 of the General Conditions.

In addition to the above, the following information must appear on the certificates:

County of Santa Barbara
Fire Station 7 Communication Complex
2411 Stanwood Drive, Santa Barbara, CA 93013
Project No. 22039

This form must be attached to all insurance forms sent to the County of Santa Barbara, General Services Department:

Francis Svedas
Authorized Insurance Company Representative's Signature

This form may be reproduced as required.

POLICY NUMBER: VUMA0300582

COMMERCIAL GENERAL LIABILITY
CG 20 10 12 19

THIS ENDORSEMENT CHANGES THE POLICY. PLEASE READ IT CAREFULLY.

ADDITIONAL INSURED – OWNERS, LESSEES OR CONTRACTORS – SCHEDULED PERSON OR ORGANIZATION

This endorsement modifies insurance provided under the following:

COMMERCIAL GENERAL LIABILITY COVERAGE PART

SCHEDULE

Name Of Additional Insured Person(s) Or Organization(s)	Location(s) Of Covered Operations
As required by written contract executed and signed by all parties prior to the date of loss but only to the extent permitted by law. The insurance afforded to such additional insured will not be broader than that which you are required by the contract or agreement to provide for such additional insured.	As designated in written contract with the Named Insured.
Information required to complete this Schedule, if not shown above, will be shown in the Declarations.	

A. Section II – Who Is An Insured is amended to include as an additional insured the person(s) or organization(s) shown in the Schedule, but only with respect to liability for "bodily injury", "property damage" or "personal and advertising injury" caused, in whole or in part, by:

1. Your acts or omissions; or
2. The acts or omissions of those acting on your behalf;

in the performance of your ongoing operations for the additional insured(s) at the location(s) designated above.

However:

1. The insurance afforded to such additional insured only applies to the extent permitted by law; and
2. If coverage provided to the additional insured is required by a contract or agreement, the insurance afforded to such additional insured will not be broader than that which you are required by the contract or agreement to provide for such additional insured.

B. With respect to the insurance afforded to these additional insureds, the following additional exclusions apply:

This insurance does not apply to "bodily injury" or "property damage" occurring after:

1. All work, including materials, parts or equipment furnished in connection with such work, on the project (other than service, maintenance or repairs) to be performed by or on behalf of the additional insured(s) at the location of the covered operations has been completed; or
2. That portion of "your work" out of which the injury or damage arises has been put to its intended use by any person or organization other than another contractor or subcontractor engaged in performing operations for a principal as a part of the same project.

- C. With respect to the insurance afforded to these additional insureds, the following is added to **Section III – Limits Of Insurance:**

If coverage provided to the additional insured is required by a contract or agreement, the most we will pay on behalf of the additional insured is the amount of insurance:

1. Required by the contract or agreement; or

2. Available under the applicable limits of insurance;
whichever is less.

This endorsement shall not increase the applicable limits of insurance.

POLICY NUMBER: VUMA0300582

COMMERCIAL GENERAL LIABILITY
CG 20 37 12 19

THIS ENDORSEMENT CHANGES THE POLICY. PLEASE READ IT CAREFULLY.

ADDITIONAL INSURED – OWNERS, LESSEES OR CONTRACTORS – COMPLETED OPERATIONS

This endorsement modifies insurance provided under the following:

COMMERCIAL GENERAL LIABILITY COVERAGE PART
PRODUCTS/COMPLETED OPERATIONS LIABILITY COVERAGE PART

SCHEDULE

Name Of Additional Insured Person(s) Or Organization(s)	Location And Description Of Completed Operations
As required by written contract executed prior to the date of occurrence but only to the extent permitted by law and the insurance afforded to such additional insured will not be broader than that which you are required by the contract or agreement to provide for such additional insured.	As designated in written contract with the Named Insured.
Information required to complete this Schedule, if not shown above, will be shown in the Declarations.	

A. Section II – Who Is An Insured is amended to include as an additional insured the person(s) or organization(s) shown in the Schedule, but only with respect to liability for "bodily injury" or "property damage" caused, in whole or in part, by "your work" at the location designated and described in the Schedule of this endorsement performed for that additional insured and included in the "products-completed operations hazard".

However:

1. The insurance afforded to such additional insured only applies to the extent permitted by law; and
2. If coverage provided to the additional insured is required by a contract or agreement, the insurance afforded to such additional insured will not be broader than that which you are required by the contract or agreement to provide for such additional insured.

B. With respect to the insurance afforded to these additional insureds, the following is added to **Section III – Limits Of Insurance:**

If coverage provided to the additional insured is required by a contract or agreement, the most we will pay on behalf of the additional insured is the amount of insurance:

1. Required by the contract or agreement; or
 2. Available under the applicable limits of insurance;
- whichever is less.

This endorsement shall not increase the applicable limits of insurance.

THIS ENDORSEMENT CHANGES THE POLICY. PLEASE READ IT CAREFULLY.

PRIMARY AND NONCONTRIBUTORY WORDING

This endorsement modifies insurance provided under the following:

COMMERCIAL GENERAL LIABILITY COVERAGE
PRODUCTS/COMPLETED OPERATIONS LIABILITY COVERAGE

With respect to coverage provided to an additional insured via attachment of an Additional Insured endorsement to this policy, such coverage is primary insurance and we will not seek contribution from any other insurance available to that additional insured.

ALL OTHER TERMS AND CONDITIONS OF THIS POLICY REMAIN UNCHANGED

POLICY NUMBER: VUMA0300582

COMMERCIAL GENERAL LIABILITY
CG 24 04 12 19

THIS ENDORSEMENT CHANGES THE POLICY. PLEASE READ IT CAREFULLY.

**WAIVER OF TRANSFER OF RIGHTS OF RECOVERY
AGAINST OTHERS TO US (WAIVER OF SUBROGATION)**

This endorsement modifies insurance provided under the following:

- COMMERCIAL GENERAL LIABILITY COVERAGE PART
- ELECTRONIC DATA LIABILITY COVERAGE PART
- LIQUOR LIABILITY COVERAGE PART
- POLLUTION LIABILITY COVERAGE PART DESIGNATED SITES
- POLLUTION LIABILITY LIMITED COVERAGE PART DESIGNATED SITES
- PRODUCTS/COMPLETED OPERATIONS LIABILITY COVERAGE PART
- RAILROAD PROTECTIVE LIABILITY COVERAGE PART
- UNDERGROUND STORAGE TANK POLICY DESIGNATED TANKS

SCHEDULE

<p>Name Of Person(s) Or Organization(s):</p> <p>Any person or organization to whom or to which you are obligated by virtue of a written contract to waive your right of recovery.</p>
<p>Information required to complete this Schedule, if not shown above, will be shown in the Declarations.</p>

The following is added to Paragraph 8. **Transfer Of Rights Of Recovery Against Others To Us** of Section IV – Conditions:

We waive any right of recovery against the person(s) or organization(s) shown in the Schedule above because of payments we make under this Coverage Part. Such waiver by us applies only to the extent that the insured has waived its right of recovery against such person(s) or organization(s) prior to loss. This endorsement applies only to the person(s) or organization(s) shown in the Schedule above.

THIS ENDORSEMENT CHANGES THE POLICY. PLEASE READ IT CAREFULLY.

DESIGNATED CONSTRUCTION PROJECT(S) GENERAL AGGREGATE LIMIT WITH A CAP

This endorsement modifies insurance provided under the following:

COMMERCIAL GENERAL LIABILITY COVERAGE

SCHEDULE

Designated Construction Projects: Construction project sites at which you perform work for additional insureds that require you to obtain per project general aggregate limits under a written contract that was executed prior to the date of any "occurrence" covered under this policy.

Maximum Aggregate Limit: \$5,000,000

- A. For all sums which the insured becomes legally obligated to pay as damages caused by "occurrences" under **COVERAGE A BODILY INJURY AND PROPERTY DAMAGE LIABILITY** and for all medical expenses caused by accidents under **COVERAGE C – MEDICAL PAYMENTS**, which can be attributed only to ongoing operations at a single designated construction project shown in the Schedule above:
1. A separate Designated Construction Project General Aggregate limit applies to each designated construction project, subject to an overall maximum aggregate limit as shown in the Schedule above, is equal to the amount of the General Aggregate Limit shown in the Declarations.
 2. The Designated Construction Project General Aggregate Limit is the most we will pay for the sum of all damages under **COVERAGE A**, except damages because of "bodily injury" or "property damage" included in the "products-completed operations hazard", and for medical expenses under **COVERAGE C** regardless of the number of:
 - a. Insureds; or
 - b. Claims made or "suits" brought; or
 - c. Persons or organizations making claims or bringing "suits".
 3. Any payments made under **COVERAGE A** for damages or under **COVERAGE C** for medical expenses shall reduce the Designated Construction Project Aggregate Limit for that designated construction project. Such payments shall not reduce the General Aggregate Limit shown in the Declarations nor shall they reduce any other Designated Construction Project General Aggregate Limit for any other designated construction project shown in the Schedule above.
 4. The limits shown in the Declarations for Each Occurrence, Fire Damage and Medical Expenses continue to apply. However, instead of being subject to the General Aggregate Limit shown in the Declarations, such limits will be subject to the applicable Designated Construction Project General Aggregate Limit.

- B. For all sums which the insured becomes legally obligated to pay as damages caused by “occurrences” under **COVERAGE A** and for all medical expenses caused by accidents under **COVERAGE C**, which cannot be attributed only to ongoing operations at a single designated construction project shown in the Schedule above:
1. Any payments made under **COVERAGE A** for damages or under **COVERAGE C** for medical expenses shall reduce the amount available under the General Aggregate Limit or the Products-Completed Operations Aggregate Limit, whichever is applicable; and
 2. Such payments shall not reduce any Designated Construction Project General Aggregate Limit.
- C. When coverage for liability arising out of the “products-completed operations hazard” is provided, any payments for damages because of “bodily injury” or “property damage” included in the “products-completed operations hazard” will reduce the Products-Completed Operations Aggregate Limit, and not reduce the General Aggregate Limit nor the Designated Construction Project General Aggregate Limit.
- D. If the applicable designated construction project has been abandoned, delayed, or abandoned and then restarted, or if the authorized contracting parties deviate from plans, blueprints, designs, specifications or timetables, the project will still be deemed to be the same construction project.
- E. The provisions of LIMITS OF INSURANCE SECTION III not otherwise modified by this endorsement shall continue to apply as stipulated.

ALL OTHER TERMS AND CONDITIONS OF THIS POLICY REMAIN UNCHANGED

COMMERCIAL AUTO
AC 70 05 03 16

THIS ENDORSEMENT CHANGES THE POLICY. PLEASE READ IT CAREFULLY.

BUSINESS AUTO PROTECTION - GOLD

This endorsement modifies insurance provided under the following:

BUSINESS AUTO COVERAGE FORM

SUMMARY OF COVERAGES

- A. Effect of This Endorsement
- B. Newly Acquired or Formed Entities
- C. Employees as Insureds – Nonowned Autos
- D. Additional Insured by Contract, Permit or Agreement
- E. Supplementary Payments – Bail Bonds
- F.S. Supplementary Payments – Loss of Earnings
- G. Personal Effects and Property of Others Extension
- H. Prejudgment Interest Coverage
- I. Fellow Employee – Officer, Managers and Supervisors
- J. Hired Auto Physical Damage
- K. Temporary Substitute Autos – Physical Damage Coverage
- L. Expanded Towing Coverage
- M. Auto Loan or Lease Coverage
- N. Original Equipment Manufacturer Parts – Leased Private Passenger Types
- O. Deductible Amendments
- P. Rental Reimbursement Coverage
- Q. Expanded Transportation Expense
- R. Extra Expense – Stolen Autos
- S. Physical Damage Limit of Insurance
- T.N. New Vehicle Replacement Cost
- U. Physical Damage Coverage Extension
- V. Transfer of Rights of Recovery Against Others To Us
- W. Section IV – Business Auto Conditions – Notice of and Knowledge of Occurrence
- X. Hired Car Coverage Territory
- Y. Emergency Lock Out
- Z.C. Cancellation Condition

COMMERCIAL AUTO

AC 70 05 03 16

A. EFFECT OF THIS ENDORSEMENT

Coverage provided under this policy is modified by the provisions of this endorsement. If there is any conflict between the provisions of this endorsement and the provision(s) of any state-specific endorsement also attached to this policy, then the provision(s) of the state-specific endorsement shall apply instead of the provisions of this endorsement that are in conflict, but only to the extent of the conflict, and only to the extent necessary to bring such provisions into conformance with the state requirement(s) contained in the provision(s) of the state-specific endorsement.

B. NEWLY ACQUIRED OR FORMED ENTITIES

The Named Insured shown in the Declarations is amended to include any organization you newly acquire or form, other than a partnership, joint venture, or limited liability company, and over which you maintain ownership or majority (more than 50%) interest; if there is no other similar insurance available to that organization. Coverage under this provision is afforded until the 180th day after you acquire or form the organization or the end of the policy period, whichever is later.

C. EMPLOYEES AS INSUREDS – NONOWNED AUTOS

The following is added to paragraph A.1. Who Is An Insured of SECTION II – COVERED AUTOS LIABILITY COVERAGE:

- d. Any "employee" of yours is an "insured" while using a covered "auto" you don't own, hire or borrow in your business or your personal affairs.

D. ADDITIONAL INSURED BY CONTRACT, PERMIT OR AGREEMENT

The following is added to A.1. Who Is An Insured of SECTION II – COVERED AUTOS LIABILITY COVERAGE:

Any person or organization that you are required to name as an additional insured in a written contract or agreement that is executed or signed by you prior to a "bodily injury" or "property damage" occurrence is an "insured" for Covered Auto Liability coverage. However, with respect to covered "autos", such person or organization is an insured only to the extent that person or organization qualifies as an "insured" under A.1. Who is an Insured of SECTION II – COVERED AUTOS LIABILITY COVERAGE:

If specifically required by the written contract or agreement referenced in the paragraph above, any coverage provided by this endorsement to an additional insured shall be primary and any other valid and collectible insurance available to the additional insured shall be non-contributory with this insurance. If the written contract does not require this coverage to be primary and the additional insured's coverage to be non-contributory, then this insurance will be excess over any other valid and collectible insurance available to the additional insured.

E. SUPPLEMENTARY PAYMENTS – BAIL BONDS

Supplementary Payments of SECTION II – COVERED AUTOS LIABILITY COVERAGE is revised as follows:

- (2) Up to \$2,500 for cost of bail bonds (including bonds for related traffic law violations) required because of an "accident" we cover. We do not have to furnish these bonds.

F. SUPPLEMENTARY PAYMENTS – LOSS OF EARNINGS

Supplementary Payments of the SECTION II – COVERED AUTOS LIABILITY COVERAGE is revised as follows:

- (4) All reasonable expenses incurred by the "insured" at our request, including actual loss of earnings up to \$500 a day because of time off from work.

G. PERSONAL EFFECTS AND PROPERTY OF OTHERS EXTENSION

- 1. The Care, Custody or Control Exclusion of SECTION II – COVERED AUTOS LIABILITY COVERAGE, does not apply to "property damage" to property, other than your property, up to an amount not exceeding \$250 in any one "accident". Coverage is excess over any other valid and collectible insurance.

- 2. The following paragraph is added to A.4. Coverage Extensions of SECTION III – PHYSICAL DAMAGE COVERAGE:

- c. We will pay up to \$500 for your property that is lost or damaged as a result of a covered "loss", without applying a deductible. Coverage is excess over any other valid and collectible insurance.

**COMMERCIAL AUTO
AC 70 05 03 16**

H. PREJUDGMENT INTEREST COVERAGE

The following paragraph is added to SECTION II – COVERED AUTOS LIABILITY COVERAGE, 2. Coverage Extensions, a. Supplementary Payments:

(7) Prejudgment interest awarded against the "insured" on that part of the judgment we pay. If we make an offer to pay the applicable limit of insurance, we will not pay any prejudgment interest based on that period of time after the offer.

I. FELLOW EMPLOYEE – OFFICERS, MANAGERS, AND SUPERVISORS

The Fellow Employee Exclusion in SECTION II – COVERED AUTOS LIABILITY COVERAGE is replaced as follows;

A. "Bodily injury" to any fellow "employee" of the "insured" arising out of and in the course of the fellow "employee's" employment or while performing duties related to the conduct of your business. This exclusion does not apply to an "insured" who occupies a position as an officer, manager, or supervisor.

J. HIRED AUTO PHYSICAL DAMAGE

If covered "auto" designation symbols 1 or 8 apply to Liability Coverage and if at least one "auto" you own is covered by this policy for Comprehensive, Specified Causes of Loss, or Collision coverages, then the Physical Damage coverages provided are extended to "autos" you lease, hire, rent or borrow without a driver; and provisions in the Business Auto Coverage Form applicable to Hired Auto Physical Damage apply up to a limit of \$100,000. The deductible will be equal to the largest deductible applicable to any owned "auto" for that coverage. Any Comprehensive deductible does not apply to fire or lightning.

K. TEMPORARY SUBSTITUTE AUTOS – PHYSICAL DAMAGE COVERAGE

The following is added to paragraph C. Certain Trailers, Mobile Equipment And Temporary Substitute Autos of SECTION I - COVERED AUTOS:

If Physical Damage Coverage is provided by this Coverage Form, the following types of vehicles are also covered "autos" for Physical Damage Coverage:

Any "auto" you do not own while used with the permission of its owner as a temporary

substitute for a covered "auto" you own that is out of service because of its:

- a. Breakdown;
- b. Repair;
- c. Servicing;
- d. "Loss"; or
- e. Destruction

The coverage that applies is the same as the coverage provided for the vehicle being replaced.

L. EXPANDED TOWING COVERAGE

- 1. We will pay up to:
 - a. \$100 for a covered "auto" you own of the private passenger type, or
 - b. \$500 for a covered "auto" you own that is not of the private passenger type,
 for towing and labor costs incurred each time the covered "auto" is disabled. However, the labor must be performed at the place of disablement.
- 2. This coverage applies only for an "auto" covered on this policy for Comprehensive or Specified Causes of Loss Coverage and Collision Coverages.
- 3. Payment applies in addition to the otherwise applicable amount of each coverage you have on a covered "auto".

M. AUTO LOAN OR LEASE COVERAGE

- 1. In the event of a total "loss" to a covered "auto", we will pay any unpaid amount due on the loan or lease, including up to a maximum of \$500 for early termination fees or penalties, for your covered "auto" less:
 - a. The amount paid under SECTION III – PHYSICAL DAMAGE COVERAGE of this policy; and
 - b. Any:
 - 1) Overdue lease/loan payments at the time of the "loss";
 - 2) Financial penalties imposed under a lease for excessive use, abnormal wear and tear or high mileage;
 - 3) Security deposits not refunded by a lessor;
 - 4) Costs of extended warranties, Credit Life insurance, Health, Accident, or Disability insurance purchased with the lease; and

**COMMERCIAL AUTO
AC 70 05 03 16**

- 5) Carry-over balances from previous leases.
2. This coverage only applies to a "loss" which is also covered under this policy for Comprehensive, Specified Causes of Loss, or Collision coverage.
3. Coverage does not apply to any unpaid amount due on a loan for which the covered "auto" is not the sole collateral.

N. ORIGINAL EQUIPMENT MANUFACTURER PARTS – LEASED PRIVATE PASSENGER TYPES

Under Paragraph C. Limit of Insurance of SECTION III – PHYSICAL DAMAGE COVERAGE, Section 4 is added as follows:

4. We will use new original equipment vehicle manufacturer parts for any private passenger type covered "auto" where required by the lease agreement which has a term of at least six months. If a new original equipment vehicle manufacturer part is not in production or distribution we may use a like, kind and quality replacement part.

O. DEDUCTIBLE AMENDMENTS

The following are added to the Deductible provision of SECTION III – PHYSICAL DAMAGE COVERAGE:

If another policy or coverage form that is not an automobile policy or coverage form issued by this company applies to the same "accident", the following applies:

1. If the deductible under this coverage is the smaller (or smallest) deductible, it will be waived:
2. If the deductible under this coverage is not the smaller (or smallest) deductible, it will be reduced by the amount of the smaller (or smallest) deductible.

If a Comprehensive or Specified Causes of Loss Coverage "loss" from one "accident" involves two or more covered "autos", only the highest deductible applicable to those coverages will be applied to the "accident," if the cause of the loss is covered for those vehicles. This provision only applies if you carry Comprehensive or Specified Causes of Loss Coverage for those vehicles, and does not extend coverage to any covered "autos" for which you do not carry such coverage.

No deductible applies to glass if the glass is repaired, in a manner acceptable to us, rather than replaced.

P. RENTAL REIMBURSEMENT COVERAGE

1. This coverage applies only to a covered "auto" for which Physical Damage Coverage is provided on this policy.
2. We will pay for rental reimbursement expenses incurred by you for the rental of an "auto" because of "loss" to a covered "auto". Payment applies in addition to the otherwise applicable amount of each coverage you have on a covered "auto." No deductibles apply to this coverage.
3. We will pay only for those expenses incurred during the policy period beginning 24 hours after the "loss" and ending, regardless of the policy's expiration, with the lesser of the following number of days:
 - a. The number of days reasonably required to repair or replace the covered "auto". If "loss" is caused by theft, this number of days is added to the number of days it takes to locate the covered "auto" and return it to you.
 - b. The number of days shown in the Schedule.
4. Our payment is limited to the lesser of the following amounts:
 - a. Necessary and actual expenses incurred.
 - b. \$75 for any one day or for a maximum of 30 days.
5. This coverage does not apply while there are spare or reserve "autos" available to you for your operations.
6. If "loss" results from the total theft of a covered "auto" of the private passenger type, we will pay under this coverage only that amount of your rental reimbursement expenses which is not already provided for under SECTION III – PHYSICAL DAMAGE COVERAGE Coverage Extension.

Q. EXPANDED TRANSPORTATION EXPENSE

Paragraph A.4.a. of SECTION III – PHYSICAL DAMAGE COVERAGE is replaced by the following:

We will pay up to \$50 per day to a maximum of \$1500 for temporary transportation expense incurred by you because of the total theft of a

**COMMERCIAL AUTO
AC 70 05 03 16**

covered "auto" of the private passenger type. We will only pay for those covered "autos" for which you carry Comprehensive or Specified Causes of Loss Coverage. We will pay for temporary transportation expenses incurred during the period beginning 24 hours after the theft and ending, regardless of the policy's expiration, when the covered "auto" is returned to use or we pay for its "loss".

R. EXTRA EXPENSE – STOLEN AUTOS

The following paragraph is added to Coverage Extensions of SECTION III – PHYSICAL DAMAGE COVERAGE:

- c. We will pay for up to \$5,000 for the expense of returning a stolen covered "auto" to you. We will pay only for those covered "autos" for which you carry Comprehensive or Specified Causes of Loss Coverage

S. PHYSICAL DAMAGE LIMIT OF INSURANCE

Under SECTION III – PHYSICAL DAMAGE COVERAGE, Paragraph C., Limit of Insurance is replaced by the following:

C. Limit Of Insurance

- 1. The most we will pay for "loss" in any one "accident" is the lesser of:
 - a. The actual cash value of the damaged or stolen property as of the time of the "loss", or
 - b. The cost of repairing or replacing the damaged or stolen property.
- 2. \$1500 is the most we will pay for "loss" in any one "accident" to all electronic equipment that reproduces, receives or transmits audio, visual or data signals which, at the time of "loss", is:
 - a. Permanently installed in or upon the covered "auto" in a housing, opening or other location that is not normally used by the "auto" manufacturer for the installation of such equipment.
 - b. Removable from a permanently installed housing unit as described in Paragraph 2.a. above or is an integral part of that equipment; or
 - c. An integral part of such equipment.
- 3. An adjustment for depreciation and physical condition will be made in determining actual cash value in the event of a total "loss".
- 4. The cost of repairing or replacing may:
 - a. Be based on an estimate which includes parts furnished by the original equip-

ment manufacturer or other sources including non-original equipment manufacturers and

- b. If a repair or replacement results in better than like kind or quality, we will not pay for the amount of the net improvement.
- 5. If we offer to pay the actual cash value of the damaged or stolen property, we will value auto advertising wraps, paint customization, and similar business related advertising modifications, in addition to the actual cash value of the property. Auto advertising wraps, paint customization, and similar business related advertising modifications will be valued at the cost to replace them with an adjustment made for depreciation and physical condition.

T. NEW VEHICLE REPLACEMENT COST

The following is added to the Limit of Insurance provision of SECTION III – PHYSICAL DAMAGE COVERAGE:

- 5. The provisions of paragraphs 1. and 3. do not apply to a covered "auto" of the private passenger type or a vehicle with a gross vehicle weight rating of 20,000 pounds or less which is a "new vehicle."

In the event of a total "loss" to your new vehicle to which this coverage applies, we will pay at your option:

- a. The verifiable "new vehicle" purchase price you paid for your damaged vehicle, not including any insurance or warranties purchased;
- b. If it is available, the purchase price, as negotiated by us, of a "new vehicle" of the same make, model, and equipment or the most similar model available, not including any furnishings, parts, or equipment not installed by the manufacturer or manufacturers' dealership; or .
- c. The market value of your damaged vehicle, not including any furnishings, parts, or equipment not installed by the manufacturer or manufacturer's dealership.

We will not pay for initiation or set up costs associated with loans or leases

As used in this endorsement, a "new vehicle" means an "auto" of which you are the original owner that has not been previ-

**COMMERCIAL AUTO
AC 70 05 03 16**

ously titled and which you purchased less than 365 days before the date of the "loss".

U. PHYSICAL DAMAGE COVERAGE EXTENSIONS

Under SECTION III – PHYSICAL DAMAGE COVERAGE, A. Coverage, Coverage Extensions, b. Loss of Use Expenses is replaced by the following:

b. Loss of Use Expenses

For Hired Auto Physical Damage, we will pay expenses for which an "insured" becomes legally responsible to pay for loss of use of a vehicle rented or hired without a driver, under a written rental contract or agreement. We will pay for loss of use expenses if caused by:

- (1) Other than collision if the Declarations indicate that Comprehensive Coverage is provided for any covered "auto";
- (2) Specified Causes of Loss only if the Declarations indicate that Specified Causes of Loss Coverage is provided for any covered "auto"; or
- (3) Collision only if the Declarations indicate that Collision Coverage is provided for any covered "auto."

However, the most we will pay for any expenses for loss of use is \$50 per day, to a maximum of \$1,500. The insurance provided by this provision is excess over any other collectible insurance.

V. TRANSFER OF RIGHTS OF RECOVERY AGAINST OTHERS TO US

The following is added to the Transfer Of Rights Of Recovery Against Others To Us Condition:

We waive any right of recovery we may have against any person or organization to the extent required of you by a written contract executed prior to any "accident" because of payments we make for damages under this coverage form.

W. NOTICE OF AND KNOWLEDGE OF OCCURRENCE

SECTION IV – BUSINESS AUTO CONDITIONS, Paragraph A is amended as follows:

6. NOTICE OF AND KNOWLEDGE OF OCCURRENCE

a. Your obligation in the Duties in the Event of Accident, Claim, Suit or Loss Condition relative to notification requirements applies only when the "accident" or "loss" is known to:

- (1) You, if you are an individual;
- (2) A partner, if you are a partnership;
- (3) A member, if you are a limited liability company; or
- (4) An executive officer or insurance manager, if you are a corporation.

b. Your obligation in the. Duties in the Event of Accident, Claim, Suit or Loss Condition relative to providing us with documents concerning a claim or "suit" will not be considered breached unless the breach occurs after such claim or "suit" is known to:

- (1) You, if you are an individual;
- (2) A partner, if you are a partnership;
- (3) A member, if you are a limited liability company; or
- (4) An executive officer or insurance manager, if you are a corporation.

X. HIRED CAR – COVERAGE TERRITORY

Item (5) of the Policy Period, Coverage Territory General Conditions is replaced by the following:

- (5) Anywhere in the world if a covered "auto" is leased, hired, rented or borrowed without a driver for a period of 30 days or less; and

Y. EMERGENCY LOCKOUT

We will reimburse you up to \$100 for reasonable expense incurred for the services of a locksmith to gain entry into your covered "auto" subject to these provisions:

- 1. Your door key, electronic key or key entry pad has been lost, stolen or locked in your covered "auto" and you are unable to enter such "auto" , or
- 2. Your keyless entry device battery dies and you are unable to enter such "auto" as a result,
- 3. Your key, electronic key or key entry pad has been lost or stolen and you have changed the lock to prevent an unauthorized entry; and

4. Original copies of receipts for services of a locksmith must be provided before reimbursement is payable.

Z. CANCELLATION CONDITION

Paragraph A.2. of the COMMON POLICY CONDITION – CANCELLATION applies except as follows:

**COMMERCIAL AUTO
AC 70 05 03 16**

If we cancel for any reason other than non-payment of premium, we will mail or deliver to the First Named Insured written notice of cancellation at least 60 days before the effective date of cancellation. This provision does not apply in those states that require more than 60 days prior notice of cancellation.