

# Water Quality Management Plan

SLO Cultivation – Carpinteria dba Cresco California  
APN: 005-310-024  
3861 Foothill Road  
Carpinteria, CA 93013

WDID Number: 3\_42CC403605

Preparation Date: January 2021, revised October 2021

**SCS ENGINEERS**

October 2021

2370 Skyway Dr.  
Suite 101  
Santa Maria, CA 93455  
805-346-6591

## Table of Contents

Section	Page
<b>1.0 Introduction And Background .....</b>	<b>1</b>
1.1 Introduction.....	1
1.2 Regulatory Background.....	1
<b>2.0 Site Location And Description.....</b>	<b>2</b>
2.1 Topography .....	3
2.2 Soils and Cover Type .....	3
2.3 Climate and Precipitation.....	4
2.4 Surface Water.....	4
2.5 Existing Site Conditions.....	5
<b>3.0 Proposed Construction.....</b>	<b>7</b>
<b>4.0 Erosion and Sediment Control .....</b>	<b>8</b>
4.1 Erosion Control .....	8
4.1.1 Current Erosion BMP Measures .....	9
4.1.1 Proposed Erosion BMP Measures .....	10
4.2 Sediment Control BMP MEASURES.....	12
4.2.1 Current Sediment Control BMP Measures.....	12
4.2.2 Proposed Sediment Control BMP Measures .....	13
<b>5.0 Waste Management BMPs .....</b>	<b>13</b>
5.1 Solid Waste Management BMPs .....	14
5.1.1 Method and Frequency of Cleaning .....	14
5.1.2 Means of Cannabis Waste Transport.....	14
5.1.3 Short-Term Waste Storage Facilities.....	14
5.1.4 Method and Area of Waste .....	15
5.1.5 Equipment Necessary to Implement the Plan .....	16
<b>6.0 Post Construction Maintenance Activities – Erosion Prevention And Sediment Control.....</b>	<b>16</b>
6.1 Maintenance.....	16
<b>7.0 Proposed Water System &amp; Nutrient Management.....</b>	<b>16</b>
7.1 Water Source & Usage .....	16
7.2 Water Cycle .....	17
7.2.1 De-Ionization Process.....	18
7.2.2 Nutrient Management Plan .....	19
7.2.3 Overview.....	19
7.2.4 Nutrient Delivery System.....	19
7.3 Water Conservation Features .....	19
7.3.1 Evaporative Barriers on Exposed Soils and Pots.....	19
7.3.2 Timed Drip Irrigation.....	19
7.3.3 Soil Moisture Monitors .....	20
7.3.4 Use of Recycled Water .....	20
7.3.5 Rain Capture.....	20
<b>8.0 Pesticide Management .....</b>	<b>21</b>

8.1	Santa Barbara County Pest Management Plan.....	21
8.1.1	Cultural Pest-Management Control Methods .....	21
8.1.2	Biological Pest-Management Control Methods .....	23
8.1.3	Chemical Pest-Management Control Methods.....	24

### Figures

Figure 1.	Vicinity Map .....	3
Figure 2.	USDA Soils Map.....	4
Figure 3.	Existing Site Conditions .....	6
Figure 4.	Proposed Site Plan.....	8
Figure 5.	Example of Velocity Dissipation Device .....	9
Figure 6.	Typical Existing Stormwater Detention Basin <sup>1</sup> .....	10
Figure 7.	Locking Mechanism of Waste Bin Onsite.....	15
Figure 8.	Water – Process Flow Diagram .....	18
Figure 9.	Drip Irrigation & Capture System .....	20

### Tables

Table 1.	WQMP Requirements & Location.....	1
Table 2.	Soil Group and Erosion Factors.....	3
Table 3.	Current and Proposed Water Usage .....	17
Table 4.	Chemicals Onsite .....	25

### Attachments

Attachment 1	Site Plan
Attachment 2	Civil Engineering Plans
Attachment 3	Existing Erosion and Sediment Control BMPs and Drainage Diagram
Attachment 4	Proposed Erosion and Sediment Control BMPs
Attachment 5	Landscaping Plans
Attachment 6	Site Specific Water Cycle Diagram
Attachment 7	De-Ionization Details

# 1.0 Introduction And Background

## 1.1 INTRODUCTION

SCS Engineers (SCS) has prepared the following Water Quality Management Plan (WQMP) on behalf of SLO Cultivation, Inc., dba as Cresco California for the property located at 3861 Foothill Road, Carpinteria, CA (Project Site or Site). This site-specific WQMP has been prepared at the request of the Santa Barbara County Department of Planning and Development (P&D) and in accordance with Santa Barbara County Article II Coastal Zoning Ordinance, *Section 35-102F.9, A.21*.

## 1.2 REGULATORY BACKGROUND

Per the Coastal Zoning Ordinance that was Published in January of 2014 and updated in July of 2020, Development Standards for Greenhouses and Related Development listed in *Section 35-102F.9, A.21* state that applicants must provide a WQMP for review and approval by P&D and consultation by Environmental Health Services (EHS), the Regional Water Quality Control Board (Water Board), and the Carpinteria Valley Water District (CVWD). It should be noted that pursuant to the consultation request included in the Article II regulations, SLO Cultivation has already consulted with the Water Board and the CVWD through each agencies respective process. SLO Cultivation has been enrolled in the Water Board’s Cannabis General Permit compliance program since July, 2018 and has filed all associated applications and annual reports. As a result, the Water Board is already well informed regarding this Project and the Site Management Plan already provided to the Water Board in 2018 covers much of the same water quality management elements included in this County specific report. Additionally, Lessor of SLO Cultivation, Ocean Breeze International submitted a request for an Intent-to-Serve Letter to CVWD and received same on July 24, 20; that request package included a description of the Project, relevant maps/plans, and the miscellaneous information needed by the District. Therefore, SLO Cultivation considers the consultation requirement to be satisfied and knowledge learned from this previous agency interaction has been incorporated into the WQMP where appropriate.

The WQMP is required for all greenhouses, greenhouse related development, and hoop structures and shall consist of the following:

Table 1. WQMP Requirements & Location

Requirement	Location in WQMP
An erosion and sediment control plan.	Section 4 & 5
The location, description and design of all post-construction Best Management Practices.	Section 4, 5, and Attachment 4
A flow diagram of the proposed water system to be used, including average and maximum daily flows.	Section 7.1
The mapped location of all existing and proposed surface and sub-surface drainage facilities.	Attachment 1 - 4
Information on the proposed water and nutrient delivery systems, specifying water conservation measures and a comprehensive nutrient management plan designed to minimize nutrient loss.	Section 7

Requirement	Location in WQMP
Pesticide Best Management Practices that minimize the use of pesticides as defined and required by the County Agricultural Commissioner.	Section 8
The location and type of treatment and disposal facilities for irrigation, wash water, boiler blowdown, water softener regeneration brines, and detention basins.	Section 7 & Attachment 1
Best Management Practices designed to eliminate or minimize polluted runoff, including but not limited to the following: <ul style="list-style-type: none"> <li>• Use of water systems that minimize surface water transport (i.e., trickle, drip, mist, hydroponic irrigation systems).</li> <li>• Use of water and nutrient recycling technologies.</li> <li>• Use of soil conservation techniques that reduce erosion and sedimentation and remove solids and associated pollutants in runoff.</li> <li>• Employment of fertilization methods that maximize the efficiency of nutrient delivery and uptake such as controlled-release fertilizers (CRF) or liquid fertilizer (LF).</li> <li>• Implementation of Integrated Pest Management techniques. All greenhouses, greenhouse related development, and hoop structures should implement measures to eliminate the need for discharge of wastewater (i.e. irrigation runoff). If any type of discharge to land, groundwater, or surface water of wastewater is proposed, then the discharger shall submit a Report of Waste Discharge to the Regional Water Quality.</li> </ul>	Section 4, 5, 6, 7 & 8
	Section 7.2
	Section 7.2
	Section 7
	Section 7
Section 8	

## 2.0 Site Location And Description

The Project Site is located at 3861 Foothill Road, also identified as APN 005-310-024, in an unincorporated region of Santa Barbara County (County) approximately one (1) mile west of the City of Carpinteria and approximately seven (7) miles east of the City of Santa Barbara. The Project Site is located within the Agricultural I (AG-I-10) zone district within the First Supervisorial District. Pursuant to Article II of the County’s Coastal Land Use Ordinance, cannabis cultivation is an allowed use in the AG-I zone district. No change in land use designation or zoning is proposed as a component of the Project. The Project Site is approximately 13.66 acres in size and is primarily accessed via a private driveway from Foothill Road. Surrounding land uses are predominantly agricultural operations including greenhouses and orchards. Low density residential development is interspersed in this predominately agricultural area. Figure 1 below is a vicinity map of the Property.

Figure 1. Vicinity Map

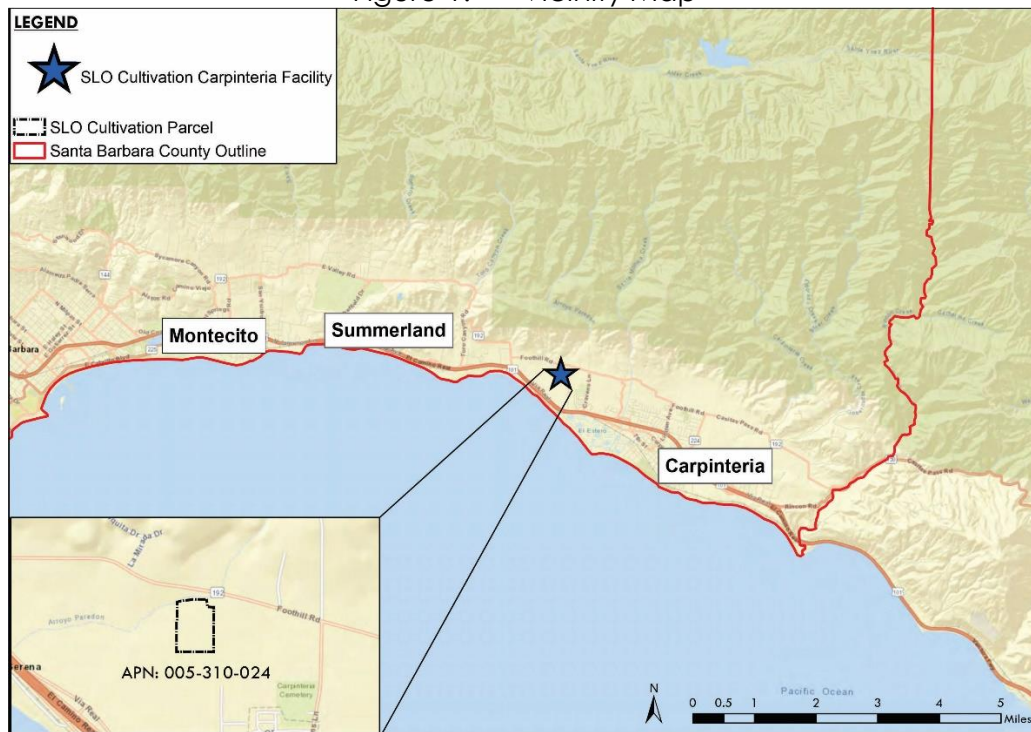

## 2.1 TOPOGRAPHY

The Project Site is primarily level land (elevations ranging from approximately 55 to 75 feet above mean sea level) with the exception of a seasonal drainage area, known as Arroyo Paredon Creek, which crosses the northern fringes of the parcel. Refer to Attachment 2 to view topographic contours on the Project Site.

## 2.2 SOILS AND COVER TYPE

According to the United States Department of Agriculture (USDA) web soil survey, soil on-Site consists of Elder sandy loam, 0-2% slopes (93.7% of Site) and Riverwash (6.3% of Site). Soil property data for each map unit component include the hydrologic soil group, erosion factor Kf for the surface horizon, erosion factor T, and the representative percentage of sand, silt, and clay in the mineral surface horizon, the surface mineral horizon properties are displayed or the first mineral horizon below an organic surface horizon. The USDA Soils Map is presented as Figure 2.

Table 2. Soil Group and Erosion Factors

Map symbol and soil name	Pct. of map unit	Acres	Hydrologic group	Kf	T factor	Representative value		
						% Sand	% Silt	% Clay
EaA – Elder sandy loam, 0 to 2 percent slopes, MLRA 14	93.7	12.5	A	.17	5	67.0	20.0	13.0
RA – Riverwash	6.3	0.8	Not Specified					

Figure 2. USDA Soils Map



## 2.3 CLIMATE AND PRECIPITATION

The weather in the Carpinteria area is typical of a Mediterranean climate. Summers are warm and dry while the winters are cool and often wet. Approximately 90% of the annual runoff occurs in less than 30-60 days, with over 80% of that coming in January, February, and March (Cachuma Resource Conservation District and the Carpinteria Creek Watershed Coalition 2005). Most of the annual precipitation and corresponding runoff occurs in only a few large storms, resulting in high peak flows and rapid return to near base-flow conditions (Beighley et al., 2004). Although rainfall is highly seasonal and varies significantly from year to year, the U.S. Department of Agriculture’s Natural Resource Conservation Service (NRCS) National Water and Climate Center for Carpinteria reports mean annual precipitation as approximately 20 inches (NRCS, 2018a). The Site lies within a Type CA5 (California) temporal rainfall distribution area (USDA-NRCS and NOAA Atlas precipitation data, 2015).

## 2.4 SURFACE WATER

United States Geological Survey (USGS) Blueline Creek, Arroyo Paredon Creek, is present and flows roughly parallel to the north property line with distances ranging from approximately 100 to 190 feet from edge of cannabis operation structures to the approximate top of bank (See Figure 3). The Arroyo Paredon Creek flows under California Highway State 101 and daylights into the Pacific Ocean approximately 4,000 feet west of the Site.

## 2.5 EXISTING SITE CONDITIONS

The Project Site contains four (4) existing greenhouse structures and twelve (12) pre-fabricated supporting structures used for agricultural storage and other supporting uses, totaling approximately 390,440 square feet of development. The existing greenhouse structural development and associated agricultural uses were approved by the County via 10DVP-00000-00010 and 11CDP-00000-00009. This existing structural development consists of:

- a. **Greenhouse 1 (GH1)**- Approximately 264,500 square feet in area with an approximate height of 17 feet, 7 inches.
- b. **Greenhouse 2 (GH2)**- Approximately 40,700 square feet in area with an approximate height of 15 feet.
- c. **Greenhouse 3 (GH3)**- Approximately 40,700 square feet in area with an approximate height of 15 feet.
- d. **Greenhouse 4 (GH4)**- Approximately 40,700 square feet in area with an approximate height of 15 feet.
- e. **Storage Containers**- Twelve (12) pre-fabricated steel storage containers (i.e. sea containers) located on concrete paved areas between GH2, GH3, and GH4. Each container is forty (40) feet in length, eight (8) feet in width, and eight and one half (8.5) feet in height.

The Project Site contains supporting uses such as an employee parking area, an internal access road, four (4) stormwater detention basins (basins), and 7-foot tall perimeter fencing. The existing employee parking area is located north of the existing greenhouses and has a pervious gravel surface. A paved internal access road is located along the eastern edge of the Project site, it is approximately 400 linear feet in length and approximately 20 feet wide. The four (4) existing basins total approximately 14,625 square feet in area and are dispersed along the western and southern edges of the Project Site. Stormwater runoff is directed from the roofs of the greenhouses to the basins via a network of drainage gutters and piping.

The remainder of the Project Site is occupied by approximately 49,117 square feet of existing agricultural disturbance (Avocado Orchard), 16,969 square feet of existing parking and vehicular access, 5,610 square feet of private road used to access parcels to the west, (which is outside the Project Site security fence) and 27,911 square feet of riparian canopy and drainage area.

The Existing Site Conditions is presented as Figure 3:



Figure 3. Existing Site Conditions

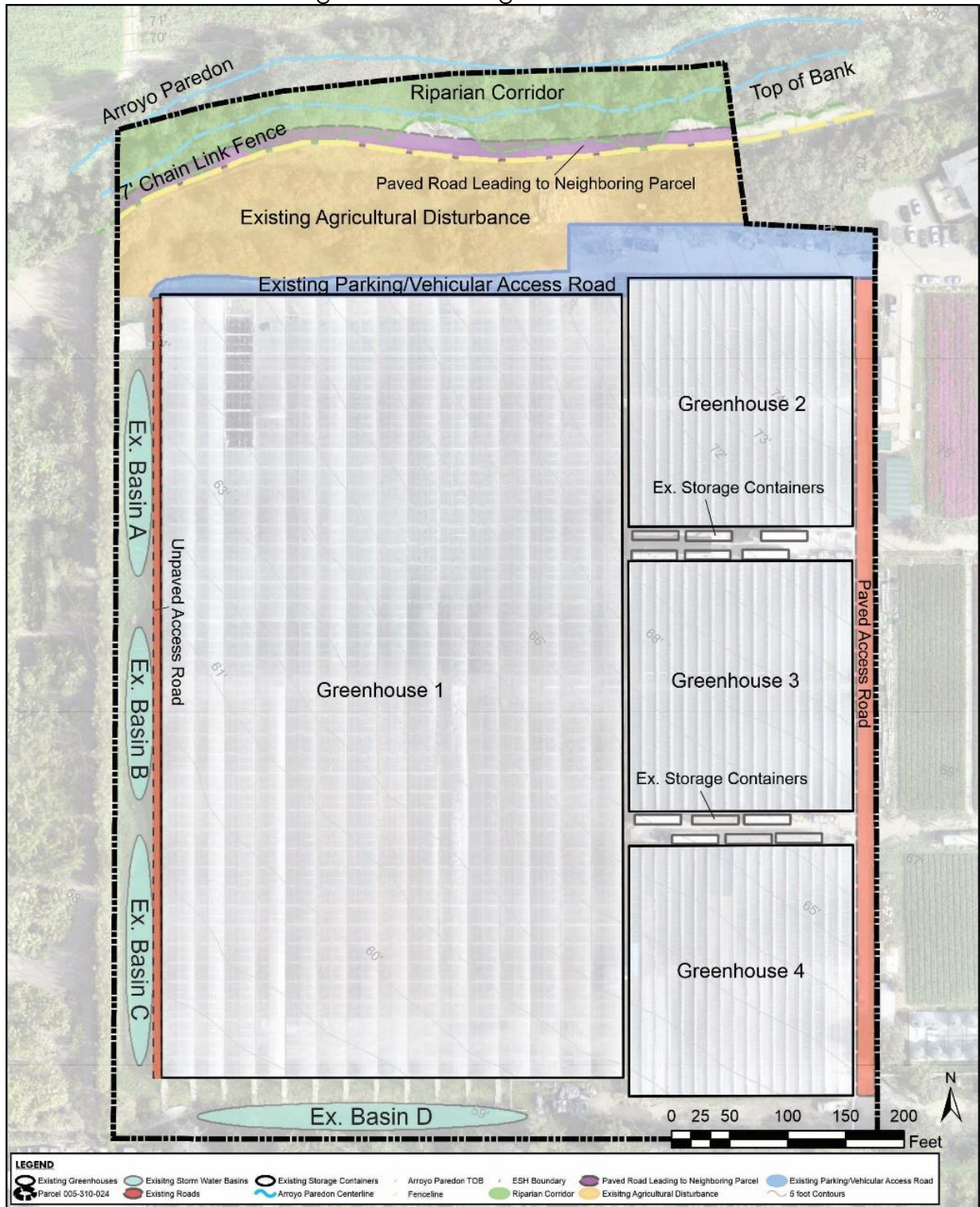

### 3.0 PROPOSED CONSTRUCTION

The proposed construction is as follows:

1. Retain existing **Greenhouse 1 (GH1)**, approximately 264,500 square feet in size, for mature mixed-light cannabis cultivation.
2. Demolition of three (3) existing greenhouses, known as **Greenhouse 2 (GH2)**, **Greenhouse (GH3)**, and **Greenhouse 4 (GH4)**, which are approximately 40,700 square foot each.
3. Development and operation of a 61,840 square foot addition to **GH1** for nursery/juvenile mixed-light cannabis cultivation.
4. Development of a new 24,751 square foot pack house which will be utilized for cannabis processing (bucking, drying, and packaging; none of these activities require water).
5. The development of sixty-five (65) onsite parking spaces.
6. Expansion of the Project Site's stormwater detention basin system.
7. Minor ancillary improvements to the Project Site including installation of security cameras and lighting, installation and use of irrigation recycling and fertigation equipment, septic waste disposal systems, and placement of cannabis waste storage containers.
8. Removal of twelve (12) pre-fabricated containers, totaling 3,840 square feet, historically used for agricultural and cannabis support activities.

It is important to note that the expansion of the Project Site's stormwater detention basins is needed to complete ministerial permitting of GH1 irrespective of the proposed cannabis uses. In the event cannabis use is not approved for the Site, the stormwater improvements are still required to continue use of the GH1 structure for cut flowers or other agricultural products. Figure 4 displays the proposed site plan. Refer to Attachment 1 for a detailed site plan.

Figure 4. Proposed Site Plan

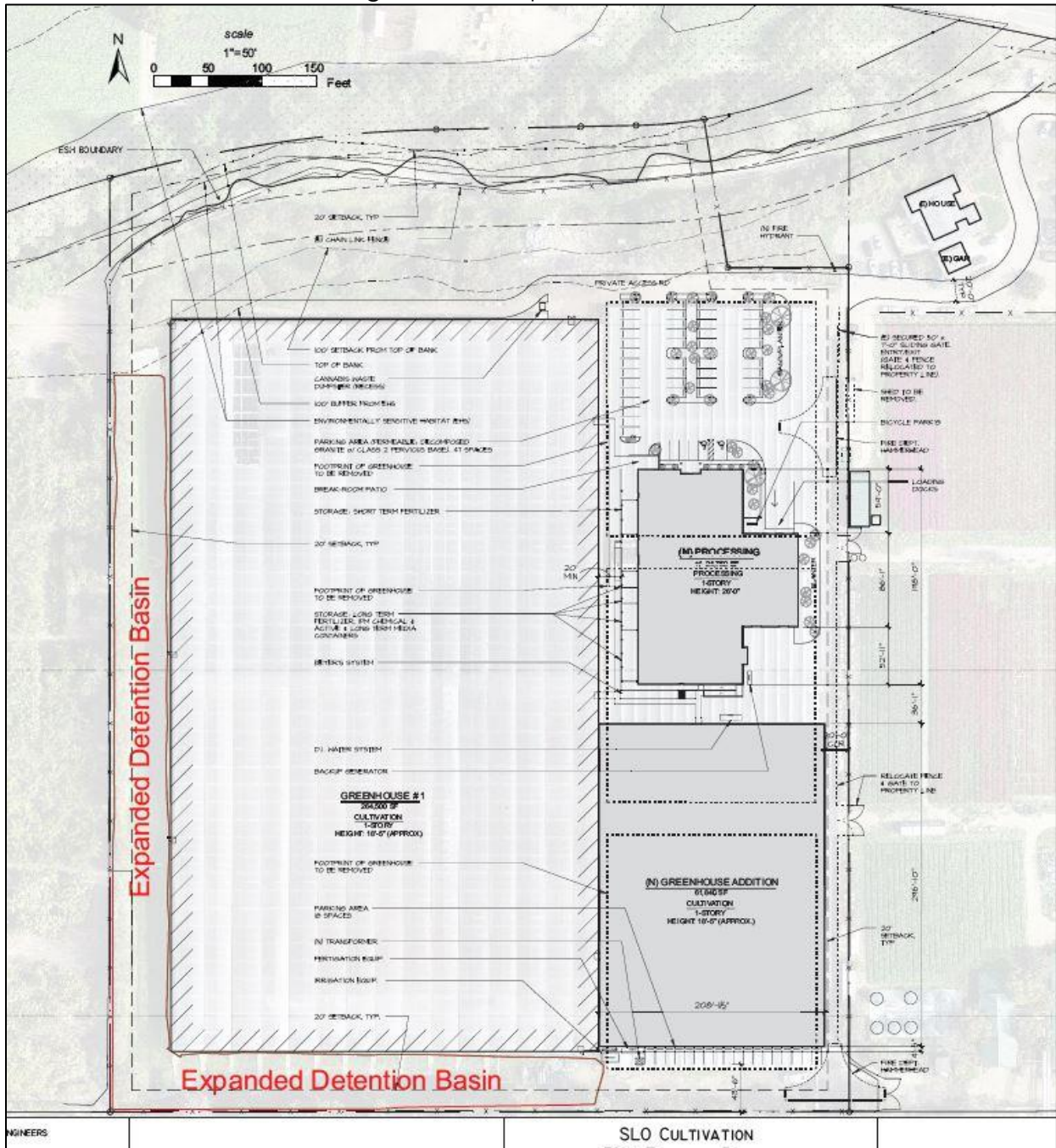

## 4.0 EROSION AND SEDIMENT CONTROL

### 4.1 EROSION CONTROL

Erosion control, also referred to as soil stabilization, consists of measures that are designed to prevent soil particles from detaching and becoming transported in stormwater runoff. Erosion control BMPs protect the soil surface by covering and/or binding soil particles.

Sufficient soil stabilization materials shall be maintained onsite to allow implementation in conformance with requirements as described in this WQMP. This includes implementation requirements for active areas and non-active areas that require deployment before the onset of rain.

#### 4.1.1 Current Erosion BMP Measures

As described section 2.0 above, the majority of the Site (~66%) is covered with existing structures. Through cover and stabilization, these areas are deemed to be a lesser threat to water quality and have a lesser concern to cause or contribute pollutants of concern in stormwater discharge. As discussed in further detail in the water system section of this WQMP, all cultivation is restricted to indoor greenhouses where plants will utilize an efficient drip irrigation system; this is a closed loop system that ensures excess irrigation water will drip into an overflow trough and be transported to holding tanks that will be recycled for additional irrigation. As a result, there should be no erosion or sediment resulting from cultivation processes. Any erosion or sediment runoff will come from existing vegetated areas outside of the greenhouses. The roofs on the greenhouses capture rainwater and discharge into one of the four (4) stormwater detention basins. Typically, stormwater then percolates into the regional aquifer and assists in maintaining recharge of the groundwater; in instances where rainfall exceeds a 25-year storm event that basins would likely reach maximum capacity and overflow drains would outfall to Arroyo Paredon Creek. The physical best management practices (BMPs) measures are as follows:

- **Velocity Dissipation Devices:** Outfall armoring of the stormwater basins is currently implemented. Rock rip-rap is used for velocity dissipation in flow and to reduce sediment at discharging locations which mitigates erosion where needed in the dirt culverts.

Figure 5. Example of Velocity Dissipation Device<sup>1</sup>

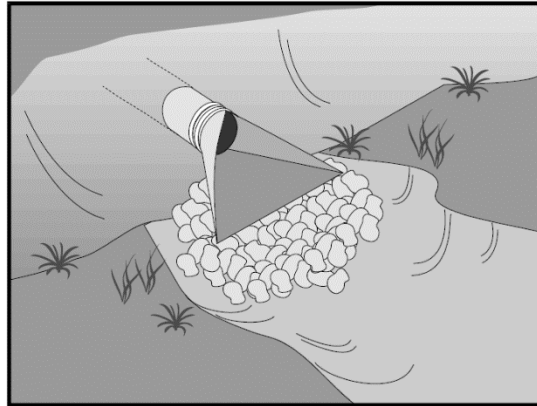

- **Roof Drains:** Roof drains are used to direct stormwater into the existing stormwater basins. Below one of the existing stormwater detention basins on the west side of the Site.

<sup>1</sup> CASQA, 2009, California Stormwater BMP Handbook.

Figure 6. Typical Existing Stormwater Detention Basin<sup>1</sup>

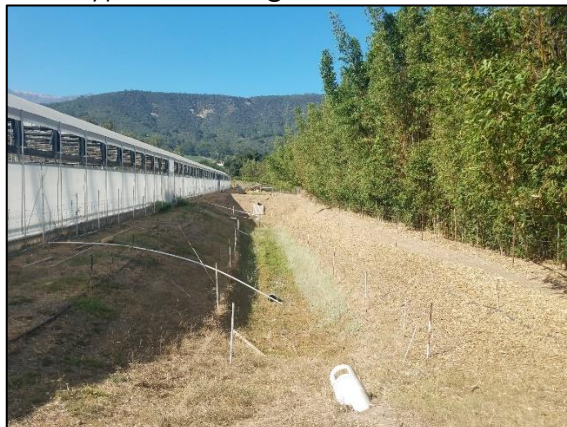

- **Concrete Overflow Weirs:** An existing concrete overflow weir is utilized on the west side of the Basin G. The weir is a flow control structure made of non-erosive material (reinforced concrete) that is currently used to control outflow from the retention basin.
- The site and roads are inspected weekly for erosion with physical BMPs measures maintained regularly, or as needed.
- Good housekeeping measures are currently implemented. All trash, materials, and debris are removed and properly disposed of, Any items stored in temporary situations will be covered to the extent practicable.
- Drainage gutters and pipes are inspected monthly during rainy months (October-April), or on an as needed basis. Prior to and during wet weather qualifying rain events, the inspection team will look for and clear any sediment buildup or debris that may have accumulated.

Attachment 3 displays the location of existing erosion and sediment control BMP's as well as all existing surface and sub-surface drainage facilities.

#### 4.1.1 Proposed Erosion BMP Measures

As mentioned in section 3.0, proposed disturbance consists primarily of expanding the stormwater detention basin system, removal of Greenhouse 2, 3 and 4, the construction of the processing building and the Greenhouse 1 addition.

Approximately forty (40) non-native avocados trees will be removed to facilitate the construction of the new revegetation area. One (1) Coast Live Oak tree will remain. The existing natural vegetation and riparian corridor located on the Northern portion of the Site will remain in place and unaffected by the Project. The existing Site fencing and paved access road located between the riparian corridor will act as a buffer to ensure that the native habitats areas are not disrupted. Once developed, areas on the northern extent of the Project Site will be replanted with a mixture of native species including Coast Live Oaks, St Mary Magnolia trees, Brisbane Box, Southern Live Oaks, Creeping Wild Rye, Mulefat, Coffee Berry, Toyon, Deer Grass, and sunset manzanita.

The proposed erosion control best management practices (BMPs) measures are as follows:

- **Low and Midflow Outlets:** Low and midflow outlets will be constructed in the expanded southwestern detention basin. The outlets are designed to reduce the velocity of water entering the basins in order to lessen the amount of erosion.
- **Velocity Dissipation Devices:** Additional rock rip-rap will be added to the existing stormwater detention basin on the southwestern side of the Site. Rip-rap outlet protection will also be constructed on the southwest corner of the Site to reduce erosion from the two (2) adjacent overflow weirs. Rock rip-rap is used for velocity dissipation in flow and to reduce sediment at discharging locations which mitigates erosion where needed in the dirt culverts.
- **Roof Drains:** Greenhouse 1 roof drain pipes will be constructed to divert approximately all of the stormwater to the expanded detention basin. Stormwater from the proposed pack house will also be directed to the expanded southwestern basin.
- **CMU Retention Wall:** The CMU block retention wall along the expanded detention basins will be constructed to increase basin capacity as well as direct overflow along the expanded basin.
- **Storm Drains:** Drains in the parking lot and packhouse will be constructed to divert stormwater runoff to the proposed detention basin. Stormwater from the proposed pack house will also be directed to the expanded southwestern basin.
- **Naturalized Vegetation:** A native landscaping planting palette is being added to the northern side of the project site. As the vegetation matures, extensive root systems will help to hold soil in place, thus reducing erosion. In addition, vegetation helps keep soil from drying rapidly and becoming susceptible to erosion. Refer to Attachment 5 for details on the proposed landscaping plans.
- **Preservation of Existing Vegetation:** The existing riparian corridor will not be disturbed during construction of the expanded detention basin. The riparian corridor is protected by the security fence and paved road on the northern side of the Project Site. One (1) existing Coast Live Oak tree will be protected north of the greenhouse and processing building. Grading and site disturbance shall remain at least 6 feet outside of the existing oak's dripline whenever feasible. If grading must encroach within that protected area, all such work shall be conducted under the supervision of the landscape architect/arborist.

Tree Protection Example<sup>2</sup>

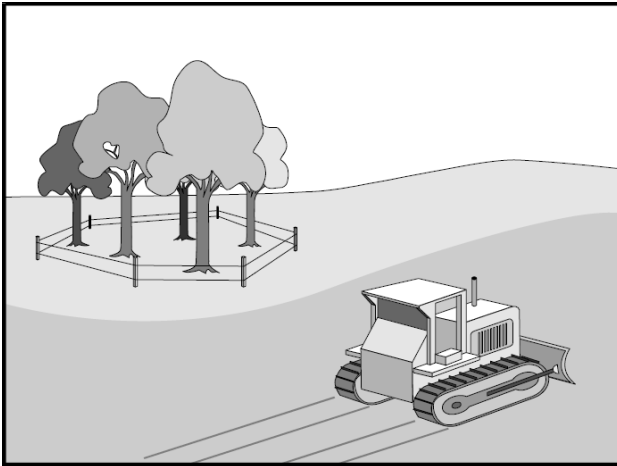

Orange Mesh Temporary Fencing Example<sup>3</sup>



- **Inspections:** The Project Site and roads are inspected weekly for erosion with physical BMPs measures maintained regularly, or as needed.
- **Housekeeping:** Good housekeeping measures are currently implemented. All trash, materials, and debris are removed and properly disposed of, Any items stored in temporary situations will be covered to the extent practicable.

Attachment 4 displays the location of proposed erosion and sediment control BMP's.

## 4.2 SEDIMENT CONTROL BMP MEASURES

Sediment controls are structural measures that are intended to complement and enhance the selected erosion control measures and reduce sediment discharge. Sediment controls are designed to intercept and settle out soil particles that have been detached and transported by the force of water.

### 4.2.1 Current Sediment Control BMP Measures

The Project Site is expected to produce low amounts of sediment erosion transport due to: 1) the Project Site is primarily covered by existing greenhouses and 2) the existing roads and surfaces that are unpaved are relatively flat with calculated slopes of 0-2 percent. However, any sediment particles that are entrained in runoff are collected in one of the four (4) existing stormwater detention basins.

The existing sediment control best management practices (BMPs) measures are as follows:

<sup>2</sup> CASQA, 2009, California Stormwater BMP Handbook.

<sup>3</sup> <http://www.best-texas.com/services/tree-protection-good-neighbor-fence/>

- **Outflow Weirs:** There is currently one (1) outflow weirs located on the west side of Basin D. Outflow weirs are inspected monthly during rainy months (October-April) or on an as needed basis during qualifying rain events. Inspections will look for and clear any sediment buildup or debris that may have accumulated. Any excess sediment will be compacted in available space.

Attachment 3 displays the location of existing erosion and sediment control BMP's as well as all existing surface and sub-surface drainage facilities.

#### 4.2.2 Proposed Sediment Control BMP Measures

As discussed above in section 3.0 and 4.1.1, proposed disturbance consists of expanding the stormwater detention basin system (Basin) in order to establish compliance with current Flood Control standards. In addition to the erosion control measures implemented, naturalized revegetation proposed on the northern side of the Project Area will provide additional sediment and erosion control.

The proposed erosion control best management practices (BMPs) measures are as follows:

- **Stormwater Detention Basins:** The four (4) existing basins will be replaced with one southwestern basin to comply with current Flood Control Standards. Any sediment particles transported through stormwater drainage will be collected in this basin.
- **Outflow Weirs:** Outflow weirs are inspected monthly during rainy months (October-April) or on an as needed basis during qualifying rain events. Inspections will look for and clear any sediment buildup or debris that may have accumulated. Any excess sediment will be compacted in available space.
- **Naturalized Revegetation** – As discussed above, the areas disturbed by construction will be replanted with naturalized vegetation. As the vegetation matures, extensive root systems will help to hold soil in place, thus reducing erosion. In addition, vegetation helps keep soil from drying rapidly and becoming susceptible to erosion. Refer to Attachment 5 for details on the proposed landscaping plans.

Attachment 4 displays the location of proposed erosion and sediment control BMP's.

## 5.0 WASTE MANAGEMENT BMPS

Waste management control practices consist of implementing procedural and structural BMPs for handling, storing and using materials to prevent the release of those materials into stormwater discharges. The proposed waste management measures are as follows:

**Material Delivery & Storage:** This BMP is applicable throughout the duration of the project. Cultivation materials such as fertilizers, pesticides, chemicals, etc. will be stored on the concrete pad on the south side of Greenhouse 1 utilizing proper secondary containment or completely enclosed storage structure as required by local and state regulations (See Attachment 4).

**Material Use:** Materials will be used by personnel with appropriate training and experience.



**Spill Prevention and Control:** Spill prevention will be ongoing throughout the duration of the Project. All personnel will be instructed as to the importance of careful handling of materials, fuels, oils, etc. and will be informed of procedures to follow in the event of a spill, including containment, cleanup, and reporting. Spill control materials will be readily available on the Project Site.

## **5.1 SOLID WASTE MANAGEMENT BMPS**

SLO Cultivation will produce cannabis plant waste through its operations, including unused seeds, stems, leaves, immature cannabis plants, and cannabis plants.

### **5.1.1 Method and Frequency of Cleaning**

SLO Cultivation prioritizes sanitation as its main method of pest prevention, regularly cleaning the receptacles according to a cleaning schedule to ensure waste disposal areas and waste receptacles remain clean and free of pestilence. The cleaning schedule details the times and areas that require cleaning on the licensed premises. Small bins used for collecting waste throughout the canopy area and processing areas are cleaned every day. Larger receptacles receive cleaning at least once per month. These receptacles are away from other cannabis activity and pose little risk to contaminating cannabis on the premises. Employees use standard cleaning materials to scrub, wipe down, and otherwise sanitize receptacles, such as brushes, sponges, non-toxic cleaning agents, hot water, rags, and other tools. Employees wash their hands before returning to work in other areas of the licensed premises.

### **5.1.2 Means of Cannabis Waste Transport**

SLO Cultivation disposes waste in the following manner:

- Collection and processing of cannabis waste by a local agency, a waste hauler franchised or contracted by a local agency, or a private waste hauler permitted by a local agency.
  - Name of Local Agency: MarBorg Industries
  - Company Business Address: 728 E Yanonali Santa Barbara, CA 93103
  - Primary contact person's name: Mario Borgatello Jr.
  - Primary contact person's phone number: (805) 963-1852

SLO Cultivation keeps receipts from the waste hauler in secure storage areas, and will continue to perpetually store them for seven (7) years as required by Section 8400 (a) of the California Code.

### **5.1.3 Short-Term Waste Storage Facilities**

Short-term waste storage occurs inside locked receptacles on site, which are metal and contain a locking mechanism that prevents unauthorized individuals from entering the container. The containers are a sufficient size and durability (are water resistant and do not rust) to withstand more waste than the premises will produce. The receptacles also have signage that prohibits certain products, including liquid, toxic, and hazardous materials. Only managers and waste haulers will have keys to the receptacle.

Figure 7. Locking Mechanism of Waste Bin Onsite.



#### 5.1.4 Method and Area of Waste

See Attachment 4 for cannabis waste receptacle location onsite.

The secure and separate area used for the storage and mixing of cannabis waste is always locked and protected from unauthorized entry. The only times waste requires handling is during the time required to move or render cannabis unusable or prepare mixed waste for transport by a waste hauler. Additionally, cannabis waste is stored and disposed of in a manner that:

- Minimizes the development of odors that could present a public nuisance;
- Minimizes the potential for such waste to attract, harbor, or become a breeding place for pests;
- Protects against contamination of cannabis, contact surfaces, facility areas, water supplies, and grounds surrounding the facilities;
- Prevents diversion, theft, or loss of cannabis plant material and cannabis products; and
- Ensures traceability through internal documentation and real-time electronic tracking in the track and trace system.

SLO Cultivation requires that staff document all waste created each day of operation in the state track-and-trace system, METRC. SLO Cultivation always places dumpsters and waste receptacles under video surveillance for protection. All waste receptacles are locked except for when in use. Additionally, SLO Cultivation will limit access to waste receptacles to those staff members responsible for destroying waste.

### **5.1.5 Equipment Necessary to Implement the Plan**

SLO Cultivation already engages in compliant waste disposal activity onsite. The equipment used includes small bins for collecting cannabis waste throughout canopy areas and processing areas and larger waste receptacles kept on site to contain all cannabis waste before a certified waste hauler removes it from the premises. Employees also use sanitation gear while cleaning the premises and handling cannabis waste, including gloves, brushes, sponges, non-toxic cleaning agents, hot water, rags, and other tools. Locks on receptacles are commercial grade and keys are kept in a secure area on site. Only Managers and the waste hauler have keys to the locking mechanisms of the waste receptacles.

## **6.0 Post Construction Maintenance Activities – Erosion Prevention And Sediment Control**

### **6.1 MAINTENANCE**

The locations and combinations of BMPs discussed in section 4 and 5 are shown on Attachment 4.

Maintenance will involve at minimum an annual visual evaluation of all BMP measures prior to commencement of the winter season. The site and its physical and biological erosion and sediment control measures will be inspected and maintained as necessary to adequately prepare for the coming winter months. During rainy months (October-April), staff is to inspect the site monthly or on an as needed basis during qualifying rain events. Inspections will look for any erosion or unstable slopes, any obstructions and changes in integrity to roads, drainage alleys, gutters, drainage pipes and stormwater detention basin; clear any sediment buildup or debris that may have accumulated. All erosion and sediment maintenance activities will be coordinated by the site manager and will include:

- Repair of erosion, such as rills;
- Repair/replacement of any damaged or leaking irrigation systems;
- Capturing of sediment and amendment with mulch or ground cover to stabilize in place;
- Clearing and compaction in available space of sediment buildup found in stormwater detention basin and drainage gutters/pipes;
- Observations/monitoring of rip-rap/overflow weirs areas during qualifying storm events; and
- Repair of erosion, slopes, compaction, and drainage channels for access roads so that they continue meeting compliance with the cannabis general order.

## **7.0 PROPOSED WATER SYSTEM & NUTRIENT MANAGEMENT**

This section has been prepared in compliance with applicable local and State regulations for the purposes of maintaining efficient use of local freshwater supplies and nutrients related to the cultivation of cannabis at the Project Site.

### **7.1 WATER SOURCE & USAGE**

The Project Site derives its primary water supply from the Carpinteria Valley Water District (CVWD). Additionally, SLO Cultivation has a water sharing agreement that allows the use of groundwater

produced by an existing private well located on the adjacent parcel to the East (APN 005-310-026). The well has historically been used to supply irrigation water for the Site so all necessary cross parcel piping connections are existing and available. However, SLO Cultivation plans to use well water in the event CVWD water is unavailable.

The Project Site is currently utilizing approximately 1/3 of its irrigation water need because there is no cultivation activity occurring in Greenhouse 1. The current and proposed water usage is shown in Table 3 below.

Table 3. Current and Proposed Water Usage

Timeframe	Units	Current Usage		Future Usage	
		Gallons	Acre Feet	Gallons	Acre Feet
Day	Average	5,000	0.015	15,000	0.046
	Maximum	6,000	0.018	20,000	0.061
Month	Average	150,000	0.46	450,000	1.38
	Maximum	180,000	0.552	600,000	1.84
Year	Average	1,825,000	5.6	5,475,000	16.8
	Maximum	216,000	0.663	7,200,000	22.1

Historical water usage for the cut flower cultivation has been 25,500-30,000 gallons per day. Therefore it is possible that the Project will result in a net reduction in onsite water demand

## 7.2 WATER CYCLE

SLO Cultivation operates a closed loop irrigation system in which no wastewater is produced; all water utilized is recycled and reused for irrigation. This section will describe the water cycle process.

Once the CVWD irrigation water enters the property it travels to water storage tanks on the southeast side of the property, the water is then processed using De-ionization technology before it is distributed to the fertigation skid, the fertigation skid then directs the water throughout the four (4) greenhouses using a high efficiency drip irrigation system with computerized timing controls. Although the timing controls will be optimized to limit over-irrigation, there is a secondary trough overflow collection system in-place to capture excess irrigation water and recycle it back into the system. The water process flow diagram is shown in Figure 8 below. Refer to Attachment 6 for an overview of how this water cycle is distributed across the Site.

Figure 8. Water – Process Flow Diagram

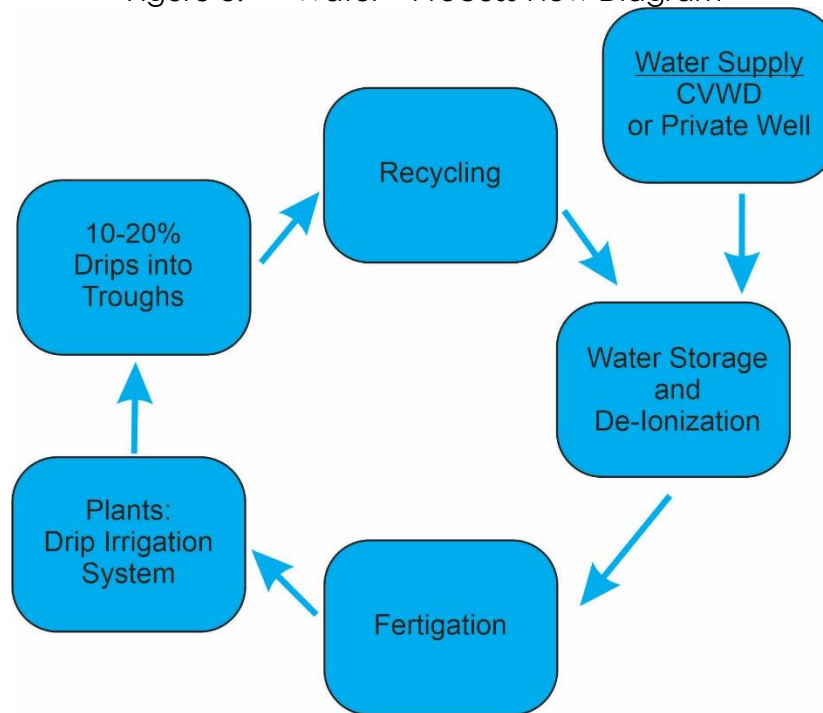

## 7.2.1 De-Ionization Process

As discussed above, the Carpinteria Valley Water District water is routed to the water storage tanks, which then sends the water through a series of De-Ionization (DI) tanks to remove excess minerals before it is transported to the fertigation system and in turn to the plants. Reverse Osmosis (RO) [RO water has been used but RO treatment has not – need to clarify] has historically been used on site to produce highly purified irrigation water suitable for cannabis cultivation, however the RO wastewater produces water with mineral concentrations above the groundwater quality objectives established in the Water Quality Control Plan for the Central Coastal Basin<sup>4</sup>. Utilizing DI tanks eliminates disposal of highly mineralized wastewater. As an aside, it is important to note that SLO Cultivation only utilized RO treated water; the physical RO system is not owned or operated or located on SLO Cultivation’s parcel 005-310-024. The RO system is located on assessor’s parcel 005-430-043 located to the southeast of SLO Cultivation’s property.

The DI system will utilize three (3) sets of the larger “Flowmax” 45 cubic feet, Portable DI water exchange tanks; there are two (2) tanks in each set (1-Cation and 1-Weak Base Anion). Each set can process 5,600 gallons per day and a total of 16,800 gallons per day for the 3 sets. The DI tanks will be rented from PureTec Industrial Water, who will exchange 2 sets of tanks per week. Subsequently, there will be no wastewater associated with the DI process because the used tanks are removed and replace weekly. See Attachment 7 for specifications on the DI Tanks.

The purpose of utilizing De-Ionization technology is to reduce sodium from the CVWD water. Analytical water quality testing completed on 7/23/20 on the CVWD water indicated the total

<sup>4</sup> Water Quality Control Plan for the Central Coastal Basin, June 2019. RWQCB, SWRCB and CEPA.

dissolved solids (TDS) is 640 mg/L. The DI technology estimates the produced water will have approximately 25 mg/L TDS.

## **7.2.2 Nutrient Management Plan**

Once the water has been de-ionized, it is directed to the fertigation skid to add nutrients. The NMP outlines the nutrient delivery system and water conservation measures developed for the Site.

## **7.2.3 Overview**

SLO uses a powdered salt based fertilizer as a nutrient regiment for the cannabis plants. The cannabis plants substrate consists of Coco Coir which contains no to very little nutrients. The fertilizer is applied to the substrate from drip irrigators at a low conductivity. The plants absorb the nutrients as a food source and all the run-off from the plants is captured and returned back to a tank farm. The run-off or leachate is blended with low conductivity water to achieve the desired conductivity prior to adding additional fertilizer and reapplying to the plants. The leachate is a closed looped recycling system.

## **7.2.4 Nutrient Delivery System**

The fertilizer consists of Nitrogen, Potassium, Phosphorus, and trace micro nutrients. The micro-nutrients include: Calcium, Magnesium, Copper, Iron, Manganese, Molybdenum, and Zinc. The nutrients are delivery from a Netafim, Netaflex fertigation skid. Small amounts of nutrients are added to the water at the fertigation skid and directly injected into the irrigation lines. Drippers are placed in the substrate to deliver the nutrient enriched water to the cannabis plants.

## **7.3 WATER CONSERVATION FEATURES**

Pursuant to the Santa Barbara County Water Efficiency for Commercial Cannabis Activities-Development Standards, SLO Cultivation plans to conserve water to the maximum extent feasible. SLO Cultivation plans to use a number of different techniques and measures to conserve water on Site during operations as outlined below.

### **7.3.1 Evaporative Barriers on Exposed Soils and Pots**

All cultivation will be restricted to indoor greenhouses which will limit direct evaporation. Additionally, all cannabis plants will be grown in pots utilizing timed, drip irrigation and coco fiber instead of typical potting/soil mix. This will ensure that the minimum amount of water will be used at any given time and irrigation will be quickly sequestered within the fiber matrix.

### **7.3.2 Timed Drip Irrigation**

An automated system, which delivers irrigation through a web of timers and automatic valves, will deliver each individual cannabis plant the precise amount of water it needs. The timing for irrigation periods will be monitored and adjusted based on variable Site conditions (seasons, weather patterns, etc.) to limit irrigation overflow to the maximum extent feasible. The automated drip irrigation will also reduce the potential for human error such as overwatering.

### 7.3.3 Soil Moisture Monitors

Widespread soil moisture monitors are not useful for this operation as excess irrigation will be detected by excessive rate of overflow into troughs and irrigation times will be adjusted in the automated system. SLO Cultivation may utilize sporadic soil moisture monitors primarily for the purpose of spot checking plants to ensure they receive sufficient irrigation.

### 7.3.4 Use of Recycled Water

In addition to limiting water use by carefully monitoring irrigation time periods, SLO has developed a water recycling program as a water conservation measure. The recycling program consists of capturing all cannabis plant run-off into drip irrigation troughs that is pumped into the tank farm. The tank farm blends the captured water with low conductivity water to achieve a desired conductivity. The tank farm feeds low conductivity water to the fertigation skid which adds nutrients. The nutrient enriched water is applied to the cannabis plants completing the recycling loop.

Figure 9. Drip Irrigation & Capture System



### 7.3.5 Rain Capture

The existing greenhouses, and associated irrigation infrastructure, on the Project Site are not designed to directly capture rain water into rain barrels or cisterns for direct return to the irrigation supply water. Rainfall in the region is too minimal and sporadic to make efficient use of such as system. Instead, rain water will be utilized as an indirect form of water conservation. As previously discussed, stormwater is directed from the greenhouse roofs to an existing network of four (4) large stormwater detention basins located along the Western and Southern edges of the Site. Stormwater then percolates into the regional aquifer and assists in maintaining recharge of the groundwater which in turn feeds the Site's private well.

## 8.0 PESTICIDE MANAGEMENT

### 8.1 SANTA BARBARA COUNTY PEST MANAGEMENT PLAN

For the purposes of this Pest Management Plan, SLO Cultivation, references *California Code of Regulations Title 3. Food and Agriculture Division 8. Cannabis Cultivation Chapter 1. Cannabis Cultivation Program Text of Modified Proposed Regulations* (the “California Code”); and *Santa Barbara County Code Chapter 50 - "Licensing of Cannabis Operations”* (“Chapter 50”). SLO Cultivation demonstrates good pest management practices, which include integrated pest-management (“IPM”) techniques. SLO Cultivation has developed a plan that describes the proposed use, storage, and application of pesticides, herbicides, and/or rodenticides by type and amount. Per Section 50-12 of Chapter 50, this plan is to be reviewed and approved by the Department and the County Agricultural Commissioner (“CAC”) prior to issuance of a land use entitlement for the proposed cultivation site.

This pest-management plan describes the type, location, timing, and methods used for any rodenticide. If rodents are a pest issue, SLO Cultivation prefers to use non-toxic alternatives to rodenticides, including:

- Cultural controls such as site maintenance and hygiene.
- Biological controls such as natural pheromones; or
- Mechanical controls like traps, gopher fencing, and weeding.

Consistent with the California Department of Pesticide Regulation (“California DPR”) determination that commercially grown cannabis is an agricultural commodity, cannabis cultivation on SLO Cultivation’s licensed site complies with the requirements of Division 6 and 7 of the Food and Agricultural Code and pertaining regulations. Staff use and store products on the site that ensures the products do not enter the natural environment, such as surface or ground waters. Per the California DPR's established regulatory process, SLO Cultivation has an Operator Identification from the CAC and may apply pesticides, herbicides, and/or rodenticides (4205199 SLO Cultivation Inc.). SLO Cultivation demonstrates knowledge of regulatory requirements regarding the safe and effective use of pesticides and/or rodenticides within the pest-management plan. If SLO Cultivation opts to use chemical rodenticides, it will provide an annual report of rodenticide use data to the CAC and County permitting.

#### 8.1.1 Cultural Pest-Management Control Methods

SLO Cultivation has the capacity to use the following cultural pest-management control methods:

- Programming and monitoring environmental controls;
- Employing good sanitation practices;
- Inspecting plants for indications of pests and disease; and
- Employing living-plant handling best practices.

SLO Cultivation employs IPM practices to minimize the likelihood and impact of pests and plant disease. IPM begins with designing and operating the facility in a way that eliminates favorable conditions for disease and pestilence to develop. Naturally, cannabis is susceptible to several influences in nature, which are defined as either “abiotic” or “biotic.” Abiotic factors are non-living



physical and chemical elements such as water, air, soil, sunlight, and minerals. Biotic factors are living or once-living organisms obtained from the biosphere, (i.e., from outside the proposed facility) and are capable of reproduction. Examples of biotic factors are animals, mold, bacteria, plants, fungi, and other organisms. Abiotic and biotic factors can influence each other to negatively impact cultivation procedures. These events may include infectious microbes, fungi, bacteria, viruses, nematodes, and noninfectious environmental factors.

The “plant disease triangle” (the combination of a pathogen, favorable environment, and susceptible host) best illustrates how disease may occur in the facility. Without all three factors present, disease or pestilence cannot occur. However, controlling one factor is not a responsible approach to cultivation, which is why SLO Cultivation prevents disease first by creating and maintaining optimal cultivation environment. Next, SLO Cultivation trains and supervises staff in managing plant health, as plants are the susceptible host in the triangle. Then, if necessary, SLO Cultivation takes direct action against pathogens and pests. The goal is to maintain the first two points of the triangle so that a pathogen does not enter or infest the facility. A fourth factor called a vector (how a pathogen enters the facility) influences disease formation, and can be insects, staff’s clothing, garden supplies, and vehicles in the vicinity of cultivation areas.

SLO Cultivation employs temperature, humidity, and ventilation controls to create an optimal environment for plants to thrive. Remote thermostats, humidity gauges, and fans help create a consistent environment throughout the entirety of the cultivation area. By programming ideal conditions with automated equipment, SLO Cultivation avoids factors that invite pests, such as hot/cold spots in the canopy, uneven irrigation, uneven airflow, and spikes in humidity.

SLO Cultivation further prevents and minimizes the impact of plant disease by employing good sanitation practices. Only a limited number of staff have access to growing plants, which limits plants’ exposure to the most vulnerable source of contamination – human bodies. Staff wear scrubs that never leave the facility and are only for working. SLO Cultivation contracts a local laundry service to wash clothing. Staff also wear other personal protective equipment, (“PPE”) such as gloves when handling cannabis, and when in production areas, staff don hairnets, beard nets (if applicable), and lab jackets. SLO Cultivation keeps rubber foot bath pads saturated with diluted hydrogen peroxide to clean shoes before entering vulnerable areas of the facility. The premises also feature handwashing sinks that staff exclusively use for washing hands. Equipment washing (multipurpose) sinks are separate from other operations.

Standard operating procedures (“SOPs”) guide staff in replicable sanitation and sterilization practices to prevent pests. Plants require daily maintenance, including aggressive pruning, defoliating, and trellising. Staff keep all cultivation areas free of plant litter, spilled media, and unused instruments. Additionally, staff never leave plant material waste left in the open and no trash remains in the facility longer than 12 hours. At the end of every shift, staff remove waste and place it in appropriate receptacles in accordance to waste management SOPs. In addition to daily cleanings, staff thoroughly disinfect cultivation areas after harvest.

Staff wash, rinse, and sanitize propagation tools after every shift. SLO Cultivation arranges tools and instruments in a tidy manner next to cultivation rooms to both help staff in their activities and to prevent contamination. Because standing water is a susceptible host to pathogens, staff store hoses coiled off the floor with nozzles upright. Floor drains around the facility help facilitate easy water/spill cleanup.

Staff also use living-plant handling best practices, including cleanly transplanting plants, arranging plants neatly and consistently on cultivation tables, and irrigating plants with minimal mess. Staff are

careful not to overcrowd plants, allowing them access to fresh moving air. Additionally, SLO Cultivation irrigates plants as early in the light period as possible and ensure plant foliage is dry prior to dark periods. These techniques minimize the potential for humidity spikes that can make plants extremely vulnerable to the pathogens botrytis (“bud rot”) and powdery mildew.

Staff are responsible for inspecting plants every day and identifying growth irregularities to ensure early identification of pest infection. SLO Cultivation strives to grow disease-resistant strains with low susceptibility to molds, fungi, and other pathogens. If plants do become infected, SLO Cultivation isolates and destroys them. Identifying a problem early and destroying a few plants saves the rest of the crop without significant financial consequences.

SLO Cultivation has quality assurance, quality control, and testing protocols throughout the cultivation process that limit the possibility for pests to enter and spread throughout the licensed premises. Staff are responsible for inspecting all plants every day. A multipoint inspection checklist monitors the following aspects of growing plants:

- Indications of nutrient deficiency;
- Even distribution of water through media;
- Grow media drainage;
- Stem strength and plant vitality;
- Environmental conditions, including:
  - Temperature,
  - Light distribution,
  - Humidity, and
  - Airflow;
- Litter, dead foliage, and clutter in cultivation rooms; and
- Standing water or spilt nutrient solution.

SLO Cultivation’s SOPs are comprehensively reviewed on an annual basis to confirm that cultural methods are effective in preventing pests from entering and spreading throughout the licensed premises.

### **8.1.2 Biological Pest-Management Control Methods**

Biological pest-management control methods are almost always safer than chemical pest-management control methods and SLO Cultivation always prefers to use them over chemicals. Biological pest-management control methods generally require less personal protective equipment while administering pest control methods. By favoring biological controls, SLO Cultivation saves labor, money, and chemical inputs otherwise required to control pests.

Biological control or “biocontrol” is a method of controlling pests using other organisms. It relies on predation, parasitism, or other natural mechanisms, but typically also involves an active human management role. Beneficial insects, such as wasps, mites, and ladybeetles can decimate harmful insects within just a few days. SLO Cultivation sources predatory insects from reliable sources and inspects all purchases, since some predatory insects can harbor mites and other microorganisms that can harm the cultivation environment.

Additionally, beneficial fungi natural in soils, such as mycorrhizae, greatly enhance plant health. Mycorrhizal fungi come into direct contact with plant roots and with the soil, adding to the plants

ability to gather nutrients and water from the soil through the fungus. SLO Cultivation uses supplemental beneficial fungi by incorporating them into grow media components. Many strains of fungi also benefit cannabis plant nutrition by improving soil health. This allows plants to uptake a greater volume of nutrients, thus improving the plants' natural immunities. The added nutrition helps plants build resistance to insects and improves crop yield.

### **8.1.3 Chemical Pest-Management Control Methods**

Per the Santa Barbara County Agricultural Commissioner's ("CAC") policy, SLO Cultivation will submit monthly reports to the CAC by the 10<sup>th</sup> day of the month that details chemical applications applied during the previous month.

SLO Cultivation uses chemical pest-management control methods as a last resort to control pests. Using chemicals can negate any benefit of using biological pest-management control methods and they require extreme caution to transport, handle, apply, store, and dispose. All chemicals on the licensed premises accompany safety data sheets ("SDS"), which guide staff in the proper handling, storage, and disposal of each substance. Pesticides, fertilizers, and other chemicals are kept separately from growing plants. SLO Cultivation employs a specific structure on the licensed premises to house pesticides. See the property diagram.

SLO Cultivation requires all staff responsible for applying pesticides to wear PPE. PPE for pesticide application includes:

- Respirator or mask as directed by chemical SDS;
- Tyvek cover-all suit;
- Gloves; and
- Goggles.

As a best practice, SLO Cultivation requires staff don more PPE than SDS require. For example, some pesticides may not explicitly require gloves to be worn while mixing or applying them, but because chemicals generally pose a health hazard, staff always wear gloves when handling any them on the licensed premises.

SLO Cultivation applies chemical pesticides in two ways: root drench and foliar application. Staff follow precise instructions when applying pesticides and take every precaution to protect the safety of other personnel, cannabis on the premises, and the environment. Before applying pesticides, staff post a re-entry interval ("REI") sign at the entrance of the applicable cultivation area. The REI, also known as restricted entry interval or re-entry time, is the minimum amount of time that must pass between the time a pesticide was applied to an area or crop and the time that personnel can go into that area without protective clothing and equipment. Each chemical on the premises has a specific REI.

SLO Cultivation contains all pesticide rinsates – the diluted pesticide mix rendered when washing pesticide sprayer tanks and other holding containers. SLO Cultivation has the capacity to transport rinsates to a labeled site. If transport is not possible, SLO Cultivation stores them in a compliant, labeled drum for pickup by a hazardous waste company. Staff have strict instruction to not tamper with containers that may contain chemicals. As a company protocol, staff must create chemical

application solutions in a manner that ensures 100% of the pesticide is used and none is wasted. This reduces the risk of pesticides flowing into water collection systems on the licensed premises.

A potential risk to using chemical pest-management control methods is spills. To mitigate the threat of chemical spillage, SLO Cultivation stores pesticides in a compliant area designed with a non-porous floor. SLO Cultivation houses a compliant spill kit and keeps updated protocols for collecting any spilled materials so that they can be hauled off by a hazardous waste pickup company.

Table 4 following list includes chemicals that may be on premises at any time:

Table 4. Chemicals Onsite

Product Name	Active Ingredient(s)
<b>Crop Application Log</b>	
Procidic 2	citric acid
Coco Wet	cocodiethanolamide
Azanguard	azadirachtin
Ecotec Plus	rosemary oil, peppermint oil, and geraniol
Regalia CG	Reynoutriasachalinensis
Javelin	bacillus thuringensis
Ancora	isaria fumosolosea
Neem Oil	neem oil
Sal's Suds	soap sodium suaralsulfate
Bio Repel	garlic oil
<b>Foliar Nutrient Log [Active ingredients not included in logs]</b>	
Phosguard	
Micro Flora	
Opfi-Dura Sulfur	
Caos	
Procidic 2	
Liquid Sulpher	
Sil Guard [0-2-5]	

## ATTACHMENTS

Attachment 1	Site Plan
Attachment 2	Civil Engineering Plans
Attachment 3	Existing Erosion and Sediment Control BMPs and Drainage Diagram
Attachment 4	Proposed Erosion and Sediment Control BMPs
Attachment 5	Landscaping Plans
Attachment 6	Site Specific Water Cycle Diagram
Attachment 7	De-Ionization Details

# Attachment 1 Site Plan

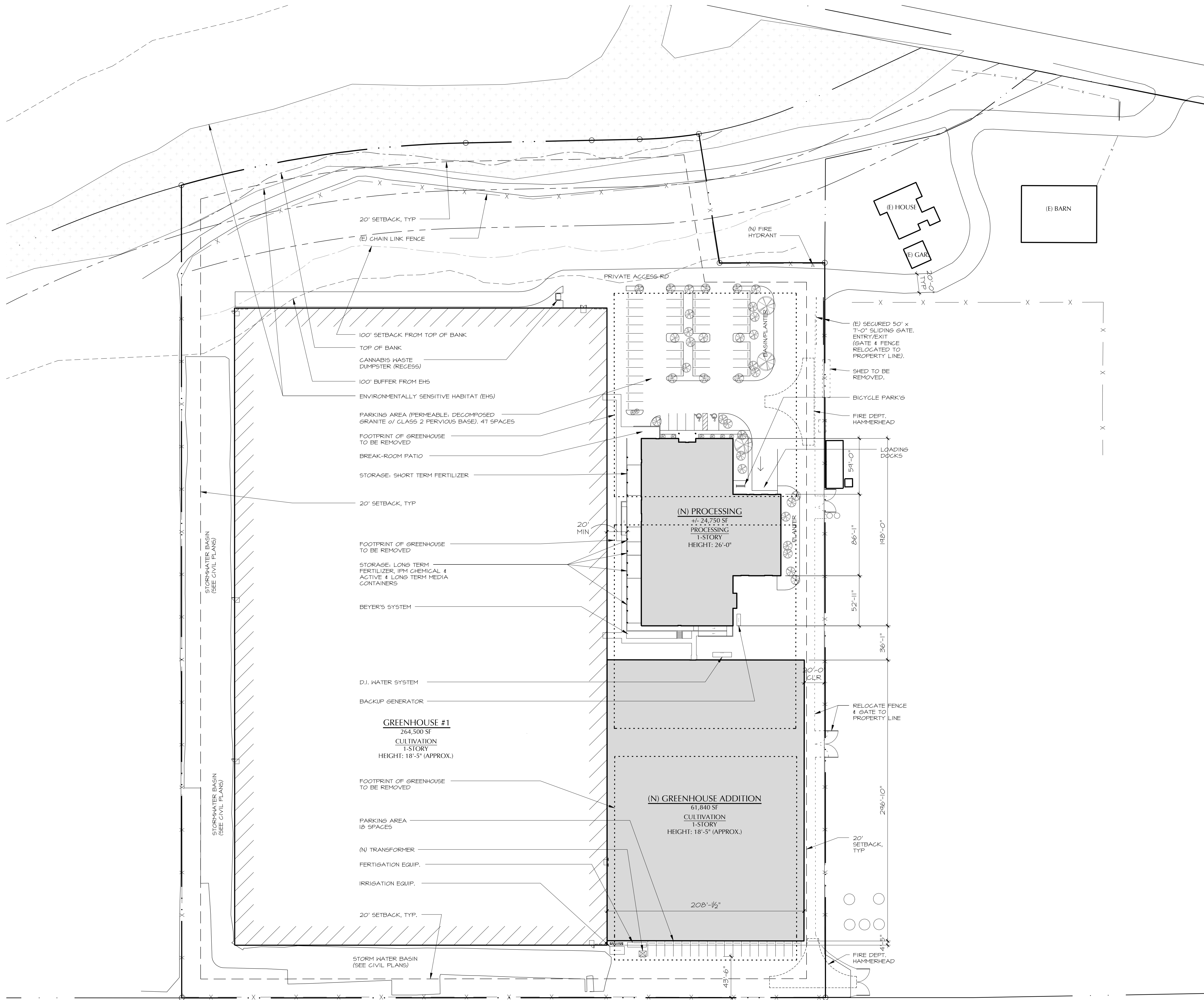

**SITE PLAN**

1"=50'



**SITE PLAN GENERAL NOTES:**

1. This plan is for architectural reference. See civil plans for specific grading and drainage information.
2. Positive drainage shall be provided away from the structure at a minimum slope of 5% for 10 feet.
3. Contractor shall verify location of all underground utilities prior to excavation.
4. Rain gutters and downspouts shall collect and discharge roof rain water run-off through an approved storm drain system. See civil plans for additional information.
5. Verify depth & separation of utilities within trenches w/ governing jurisdiction and comply w/ all applicable codes. Architect to be notified of any conflicts.



ARCHITECTURE

924 anacapa st  
suite: 2-U  
santa barbara, ca  
93101  
805.564.6074

**SLO CULTIVATION**  
3861 Foothill Rd  
Carpinteria, CA

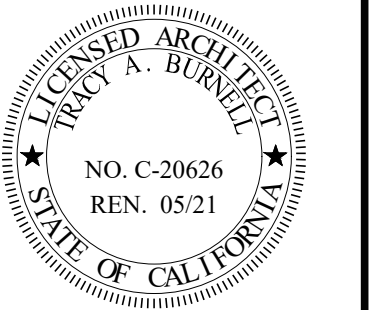

sheet description  
SITE PLAN

- date:**
- 8-7-2020
  - 8-20-2020
  - 8-28-2020
  - 9-3-2020
  - 9-9-2020
  - 9-17-2020
  - 12-9-2020
  - 12-18-2020
  - 12-29-2020
  - 1-13-2021
  - 2-3-2021
  - 2-9-2021
  - 2-10-2021
  - 2-18-2021
  - 4-27-2021
  - 6-1-2021
  - 7-6-2021
  - 9-15-2021
  - 10-1-2021

sheet no:  
**A-1**

# Attachment 2      Civil Engineering Plans



# GRADING AND DRAINAGE PLANS

## FOR

# SLO CULTIVATION - 3861 FOOTHILL RD

### CARPINTERIA, CALIFORNIA COUNTY OF SANTA BARBARA



#### COUNTY GENERAL NOTES

- OWNER AND OR OWNER'S CONTRACTOR SHALL PROTECT PUBLIC INFRASTRUCTURE FROM DAMAGE DURING THE COURSE OF CONSTRUCTION. NOTE: THE EXISTING STREET SECTIONS MAY BE SUBSTANDARD, AND THE CONTRACTOR SHALL PROTECT THE PUBLIC INFRASTRUCTURE FROM DAMAGE BY HEAVY LOADING/ EQUIPMENT DURING THE COURSE OF CONSTRUCTION. THE CONTRACTOR SHALL REPAIR, AT OWNER'S EXPENSE, ANY/ ALL DAMAGE TO PUBLIC INFRASTRUCTURE INCURRED DURING AND/ OR DUE TO CONSTRUCTION, TO THE SATISFACTION OF THE CITY ENGINEER.
- WHERE DETERMINED NECESSARY BY THE COUNTY ENGINEER, DAMAGED PORTIONS OF THE EXISTING CURB, GUTTER, AND SIDEWALK ALONG THE PROPERTY FRONTAGE SHALL BE REPLACED TO THE SATISFACTION OF THE CITY ENGINEER BEFORE FINAL APPROVAL.
- ENCROACHMENT PERMIT(S) MUST BE OBTAINED BEFORE ANY/ ALL WORK IN PUBLIC RIGHT- OF-WAY.
- COUNTY STREETS ARE TO REMAIN OPEN TO THROUGH TRAFFIC AT ALL TIMES. NO TEMPORARY OR LONG TERM PARKING OR STORAGE OF CONSTRUCTION EQUIPMENT OR MATERIALS SHALL OCCUR WITHOUT PRIOR ISSUANCE OF AN ENCROACHMENT PERMIT.
- A TRAFFIC AND PEDESTRIAN CONTROL PLAN IS REQUIRED FOR ANY DETOURS OR REROUTING OF TRAFFIC. DURING CONSTRUCTION, IT SHALL BE THE RESPONSIBILITY OF THE CONTRACTOR TO PROVIDE FOR SAFE TRAFFIC CONTROL IN AND AROUND THE SITE. THIS MAY INCLUDE BUT SHALL NOT BE LIMITED TO SIGNS, FLASHING LIGHTS, BARRICADES AND FLAG PERSONS AS DIRECTED BY THE BUILDING OFFICIAL OR THE COUNTY ENGINEER.
- EXCAVATION WITHIN THE STREETS SHALL BE COVERED WITH TRAFFIC RATED STEEL PLATES OR BACKFILLED AND PAVED, TO THE SATISFACTION OF THE COUNTY ENGINEER, PRIOR TO THE END OF WORK EACH DAY.
- EROSION AND DRAINAGE CONTROL FEATURES SHALL BE INSTALLED TO PREVENT SEDIMENT FROM LEAVING THE SITE. EROSION CONTROL DEVICES SHALL BE INSTALLED AND IN PLACE FOLLOWING DAILY CONSTRUCTION ACTIVITIES. THE APPLICANT SHALL NOTIFY THE ENGINEERING DIVISION OF ANY CHANGES IN CONSTRUCTION WHICH WILL REQUIRE ADDITIONAL EROSION CONTROL MEASURES OR OTHER CHANGES TO THE EROSION CONTROL PLAN.
- WASTE MATERIALS SHALL NOT BE WASHED INTO THE STORM DRAIN SYSTEM. THIS INCLUDES BUT IS NOT LIMITED TO SOIL, PAINT, STUCCO, GROUT, COLOR COAT, CONCRETE DUST, SAW RESIDUES, GRINDINGS, OIL, ETC.
- DURING THE CONSTRUCTION PERIOD, THE PROJECT FRONTAGE(S) SHALL BE SWEEPED DAILY AND KEPT FREE OF DIRT, DUST AND DEBRIS. AT THE CONCLUSION OF CONSTRUCTION, PRIOR TO THE ISSUANCE OF AN OCCUPANCY PERMIT, THE FRONTAGE(S) SHALL BE INSPECTED BY THE CITY ENGINEER AND REPAIRS COMPLETED AS DIRECTED TO THE SATISFACTION OF THE COUNTY ENGINEER.

#### COUNTY GRADING NOTES

- LOT GRADING SHALL MEET THE MINIMUM REQUIREMENTS OF THE LATEST CBC EDITION.
- DRAINAGE SHALL BE CARRIED TO THE STREET OR OTHER IMPROVED DRAINAGE DEVICE VIA A NON-EROSIVE DRAINAGE DEVICE.
- NO GRADING OR DRAINAGE IMPROVEMENTS WHICH ALTER EXISTING DRAINAGE COURSES OR CONCENTRATE DRAINAGE TO ADJACENT PROPERTIES SHALL BE ALLOWED WITHOUT PRIOR APPROVAL FROM THE COUNTY ENGINEER.

#### COUNTY STANDARD EROSION CONTROL NOTES

- EROSION CONTROL MEASURES SHALL BE FULLY INSTALLED AT ALL TIMES.
- EROSION CONTROL MEASURES SHALL BE FULLY INSTALLED PRIOR TO GROUND DISTURBANCE. CITY STAFF SHALL BE NOTIFIED AND INSPECT PRIOR TO GROUND DISTURBANCE.
- ALL SITE ACCESS SHALL BE PROTECTED AGAINST EROSION AT ALL TIMES THAT WORK IS NOT BEING PERFORMED ON THE SITE, INCLUDING EVENINGS, WEEKENDS AND HOLIDAYS. SUCH PROTECTION MAY BE REMOVED TO PROVIDE ACCESS TO THE SITE DURING WORK HOURS IF AND WHEN IT IS NOT REQUIRED DUE TO WEATHER CONDITIONS.
- PROPERTY FRONTAGE SHALL BE SWEEPED CLEAN AT THE END OF EACH DAY.
- THE FIRST DOWNSTREAM STORM DRAIN INLET SHALL BE PROTECTED PER DETAIL.
- ALL STOCKPILES SHALL BE PROTECTED AGAINST WIND AND WATER EROSION, PER DETAIL, IMMEDIATELY UPON PLACEMENT.
- PERMANENT EROSION CONTROL MEASURES SHALL BE FULLY ESTABLISHED TO THE SATISFACTION OF THE CITY ENGINEER PRIOR TO FINAL.
- STRUCTURAL STORMWATER CONTROL MEASURES SHALL BE INSPECTED BY THE ENGINEER OF RECORD AND CITY STAFF AT THE TIME OF INSTALLATION.
- PROJECTS SUBJECT TO POST-CONSTRUCTION REQUIREMENTS SHALL HAVE STORMWATER CONTROL PLAN RECORDED WITH THE COUNTY OF SAN LUIS OBISPO PRIOR TO FINAL.
- IN THE EVENT OF OFF-SITE EROSION, THE PROPERTY OWNER AND/ OR HIS REPRESENTATIVE(S) SHALL BE RESPONSIBLE FOR CLEANUP AND ALL ASSOCIATED COSTS OR DAMAGES.
- EROSION CONTROL PLANS REPRESENT THE MINIMUM ACCEPTABLE PROTECTION. FURTHER MEASURES WILL BE REQUIRED, TO THE SATISFACTION OF THE COUNTY ENGINEER IN THE EVENT OF INADEQUACY OR FAILURE.

#### Sheet List Table

SHEET NUMBER	REV	DRAWING TITLE
C1		TITLE SHEET
C2		GRADING - KEY MAP
C3		GRADING-PROCESSING BUILDING
C4		GRADING-GREENHOUSE ADDITION
C5		GRADING-BASINS
C6		CROSS SECTIONS A-B
C7		UTILITY PLAN
C8		EROSION CONTROL PLAN
C9		EROSION CONTROL DETAILS
C10		DETAILS SHEET

#### EARTHWORK QUANTITIES

**PARKING LOT AND BUILDING GRADING:**  
 • 1,390 CUT CUBIC YARDS  
 • 3,605 FILL CUBIC YARDS  
 • 2,215 IMPORT CUBIC YARDS  
 • 174,580 SQ. FT. DISTURBED AREA (4.0 AC)

**Basin Grading:**  
 • 4,640 CUT CUBIC YARDS  
 • 345 FILL CUBIC YARDS  
 • 4,295 EXPORT CUBIC YARDS  
 • 40,485 SQ. FT. DISTURBED AREA (0.93 AC)

**NOTE:**  
 EARTHWORK NUMBERS DO NOT INCLUDE SHRINKAGE

#### DECLARATION OF RESPONSIBLE CHARGE

I HEREBY DECLARE THAT I AM THE ENGINEER OF RECORD FOR THIS PROJECT AND THAT I HAVE EXERCISED RESPONSIBLE CHARGE OVER THE PROJECT AS DEFINED IN SECTION 6703 OF THE BUSINESS AND PROFESSIONS CODE. THESE PLANS AND SPECIFICATIONS, TO THE BEST OF MY KNOWLEDGE, COMPLY WITH CURRENT STANDARDS.

ANY ERRORS, OMISSIONS, OR OTHER VIOLATIONS OF THOSE ORDINANCES, STANDARDS OR DESIGN CRITERIA ENCOUNTERED DURING CONSTRUCTION SHALL BE CORRECTED AND SUCH CORRECTIONS REFLECTED ON CORRECTED PLANS.

DAVID W. CHANLEY R.C.E. 70849

#### PROJECT CONTACTS:

**OWNER:**  
 CRESCO LABS  
 400W. ERIE STREET SUITE 110  
 CHICAGO, IL 60654

**PLANNER:**  
 SCS ENGINEERS  
 NATHAN EADY  
 2370 SKYWAY DRIVE, SUITE 101  
 SANTA MARIA, CA 93455

**CIVIL:**  
 DIVERSIFIED PROJECT SERVICES INTERNATIONAL  
 705 FIERO LANE, SUITE 10  
 SAN LUIS OBISPO, CA 93401  
 PH: (805)250-2891  
 CONTACT: ALBERTO LOPEZ  
 ALOPEZ@DPSIINC.COM

**ARCHITECT:**  
 BBP ARCHITECTURE  
 TRACY BURNELL  
 924 ANACAPA STREET, SUITE-2-U  
 SANTA BARBARA, CA 93101  
 PH: (805) 564-6074

**SOILS ENGINEER:**  
 GEODON WEST, INC.  
 REX PANOFY  
 3303 NORTH SAN FERNANDO BOULEVARD SUITE 100  
 BURBANK, CA 91504

#### SITE INFORMATION

LOCATION: 3861 FOOTHILL RD, CARPINTERIA, CA 93110  
 APN: 005-310-024  
 SITE AREA: 13.66 ACRES

#### BENCHMARK

ELEVATIONS SHOWN HEREON ARE NAVD88 AND CONTROL WAS PREVIOUSLY ESTABLISHED BY STANTEC.

#### BASIS OF BEARINGS

THE "BASIS OF BEARING" IS GRID NORTH STATE PLANE COORDINATES FOR ZONE 5 AND OBSERVED LOCALLY BY GPS OBSERVATION.

#### UNDERGROUND UTILITY STATEMENT

THE EXISTENCE AND LOCATION OF ANY UNDERGROUND UTILITY PIPES OR STRUCTURES SHOWN ON THESE PLANS ARE OBTAINED BY A SEARCH OF THE AVAILABLE RECORDS. TO THE BEST OF OUR KNOWLEDGE THERE ARE NO EXISTING UTILITIES EXCEPT AS SHOWN ON THIS MAP.

THE CONTRACTOR IS REQUIRED TO TAKE DUE PRECAUTIONARY MEASURES TO PROTECT THE UTILITY LINES SHOWN AND ANY OTHER LINES NOT OF RECORD OR NOT SHOWN ON THIS DRAWING.

ENGINEER SHALL NOT BE RESPONSIBLE FOR THE ACCURACY OR COMPLETENESS OF ANY SUCH INFORMATION OR DATA.

UNDERGROUND SERVICE ALERT SHALL BE CONTACTED TWO WORKING DAYS PRIOR TO CONSTRUCTION BY CALLING (800) 642-2444.

#### SCOPE OF WORK

GRADING AND DRAINAGE PLAN FOR IMPROVEMENT PLAN OF EXISTING FACILITY INCLUDING DRIVEWAY, DRIVE AISLES, PARKING STALLS, SWALES, DRAINAGE BASINS AND TRASH ENCLOSURES.

#### LEGEND

- 100 — EXISTING CONTOURS - MAJOR
- — — EXISTING CONTOURS - MINOR
- - - - - EXISTING GRADE BREAK
- o EXISTING CHAINLINK FENCE
- x EXISTING BARB WIRE FENCE
- 100 — CONTOURS - MAJOR
- — — CONTOURS - MINOR
- — — GRADE BREAK
- — — LIMITS OF GRADING
- D STORM DRAIN (SIZE AS NOTED)
- FLOW LINE
- x EXISTING CHAIN LINK FENCE

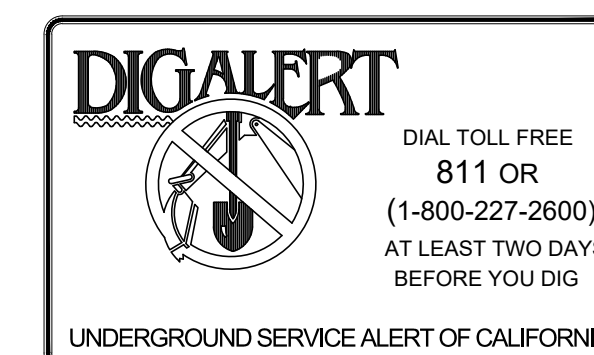

THE DELIVERY OF THIS DRAWING SHOULD NOT BE CONSTRUED TO PROVIDE AN EXPRESS WARRANTY OR GUARANTEE TO ANYONE THAT ALL DIMENSIONS AND DETAILS ARE EXACT OR TO INDICATE THAT THE USE OF THIS DRAWING IMPLIES THE REVIEW AND APPROVAL OF DPSI OF ANY FUTURE USE. ANY USE OF THIS INFORMATION IS AT THE SOLE RISK OF THE USER.

**TITLE SHEET**  
**SLO CULTIVATION**  
**3861 FOOTHILL ROAD**  
**CARPINTERIA, CA**

SHEET  
**C1**  
 OF 8 SHEETS  
 PROJECT: 201056  
 PLUMED 2023-10-11

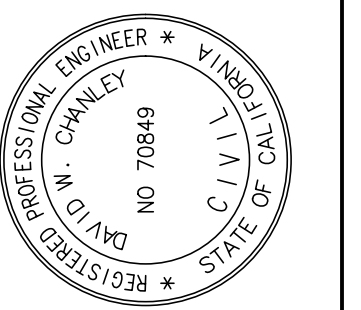

APPROVED:

DATE

DATE

AGENCY REPRESENTATIVE

SHEET

**C1**

OF 8 SHEETS

PROJECT: 201056

PLUMED 2023-10-11







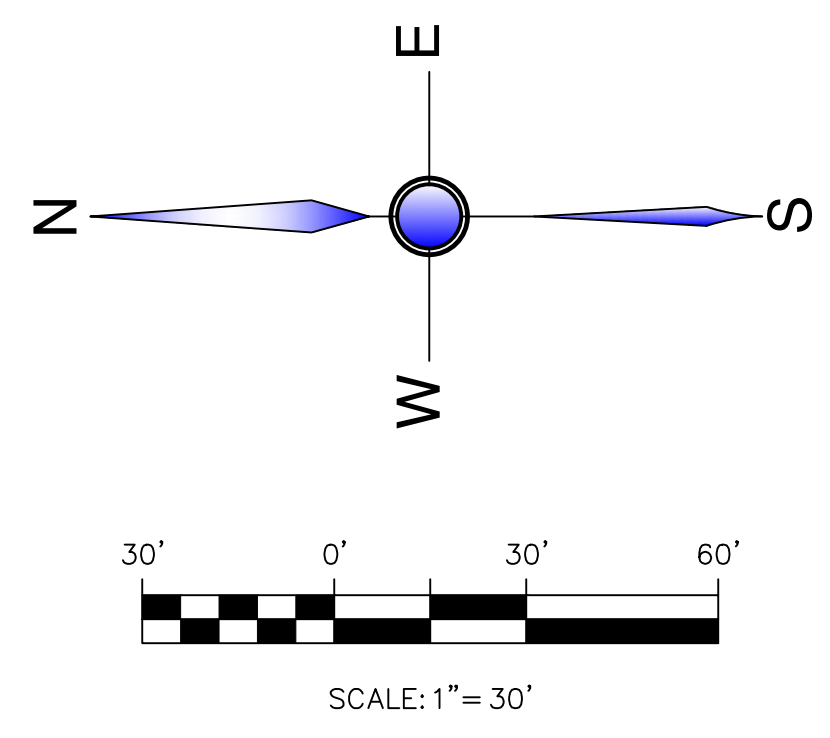
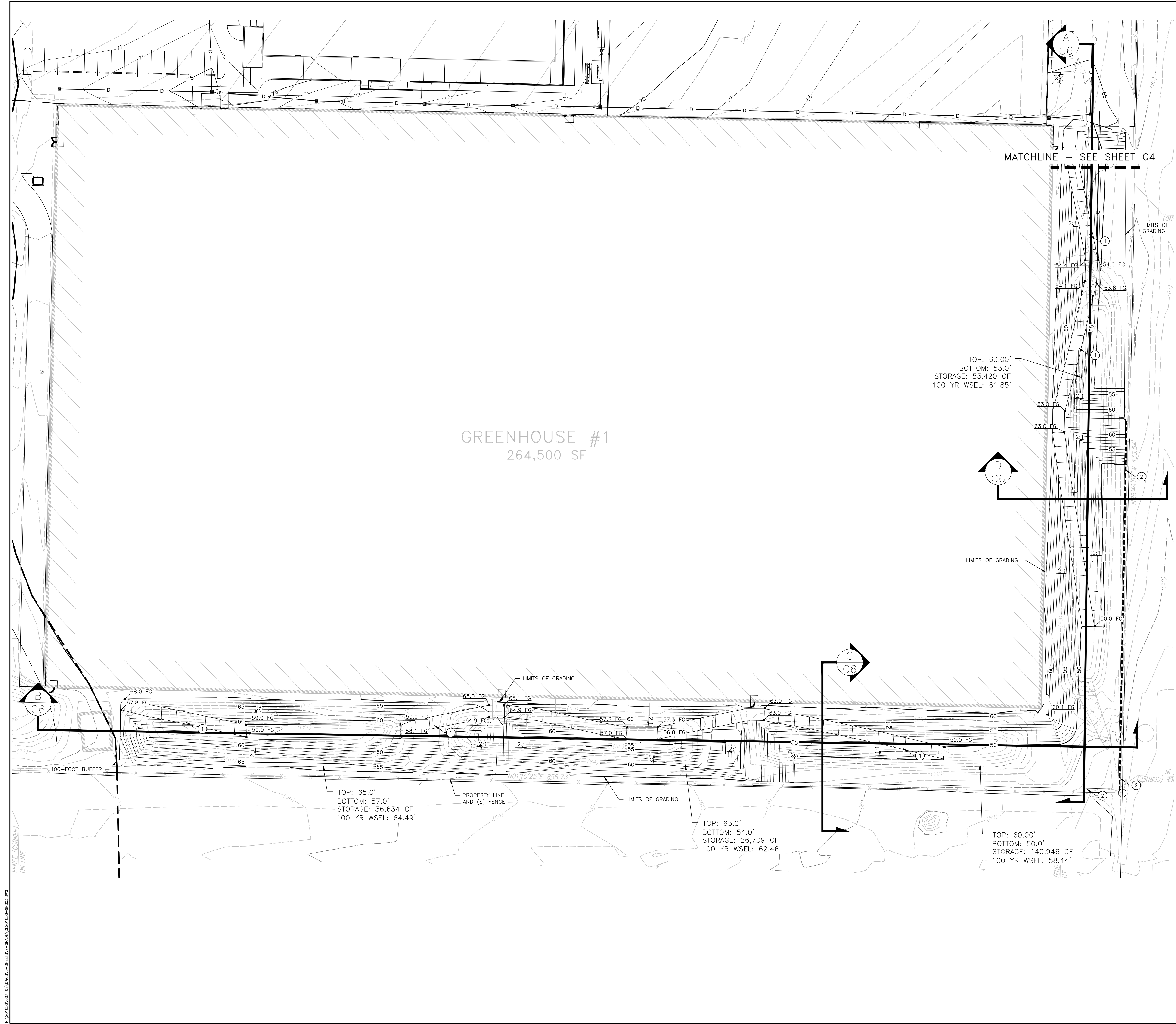

**CONSTRUCTION NOTES**

- ① CONSTRUCT 8' ACCESS RAMP TO BASIN. SEE CROSS SECTION A AND B, SHEET C6 FOR DETAIL.
- ② CONSTRUCT RETAINING WALL.

**NOTE:**  
 BFE WAS DETERMINED TO BE 2.5' ABOVE HIGHEST ADJACENT GRADE. THE HIGHEST ADJACENT GRADE WAS DETERMINED TO BE 77.5'. THEREFORE THE BFE IS 80.0'. SINCE THE FINISHED FLOOR ELEVATION IS BELOW BFE THE BUILDING WILL BE DRY FLOOD PROOFED UP TO THE BFE OF 80.0'.

APPROVED: \_\_\_\_\_ DATE \_\_\_\_\_  
 AGENCY REPRESENTATIVE \_\_\_\_\_

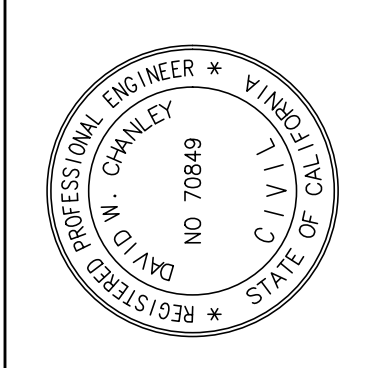

APP	REVISIONS	DATE	REV	BY
	ISSUED FOR SUBMITTAL	10/07/21	A	

**GRADING-BASINS  
 SLO CULTIVATION**  
 3861 FOOTHILL ROAD  
 CARPINTERIA, CA

SHEET **C5**  
 OF 8 SHEETS  
 PROJECT: 201056  
 PLOTTED: 2021-10-11

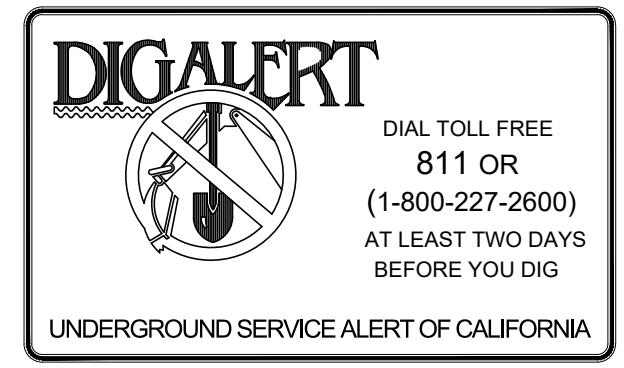

THE DELIVERY OF THIS DRAWING SHOULD NOT BE CONSTRUED TO PROVIDE AN EXPRESS WARRANTY OR GUARANTEE TO ANYONE THAT ALL DIMENSIONS AND DETAILS ARE EXACT OR TO INDICATE THAT THE USE OF THIS DRAWING IMPLIES THE REVIEW AND APPROVAL OF DPSI OF ANY FUTURE USE. ANY USE OF THIS INFORMATION IS AT THE SOLE RISK OF THE USER.

N:\201056\DOT\_CD\DWG\LS-SHEETS\2-DRAWING\201056-0003.dwg



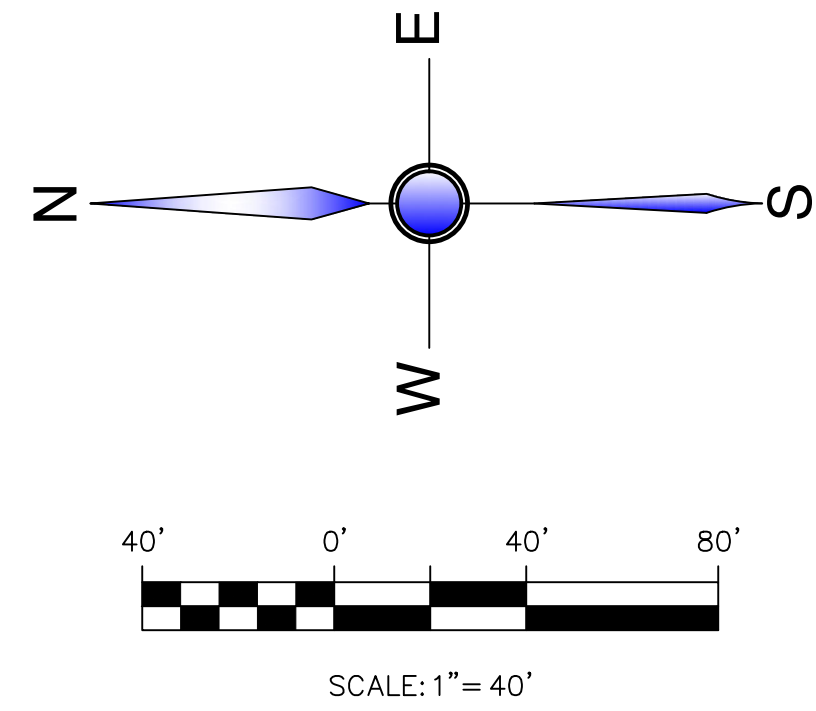
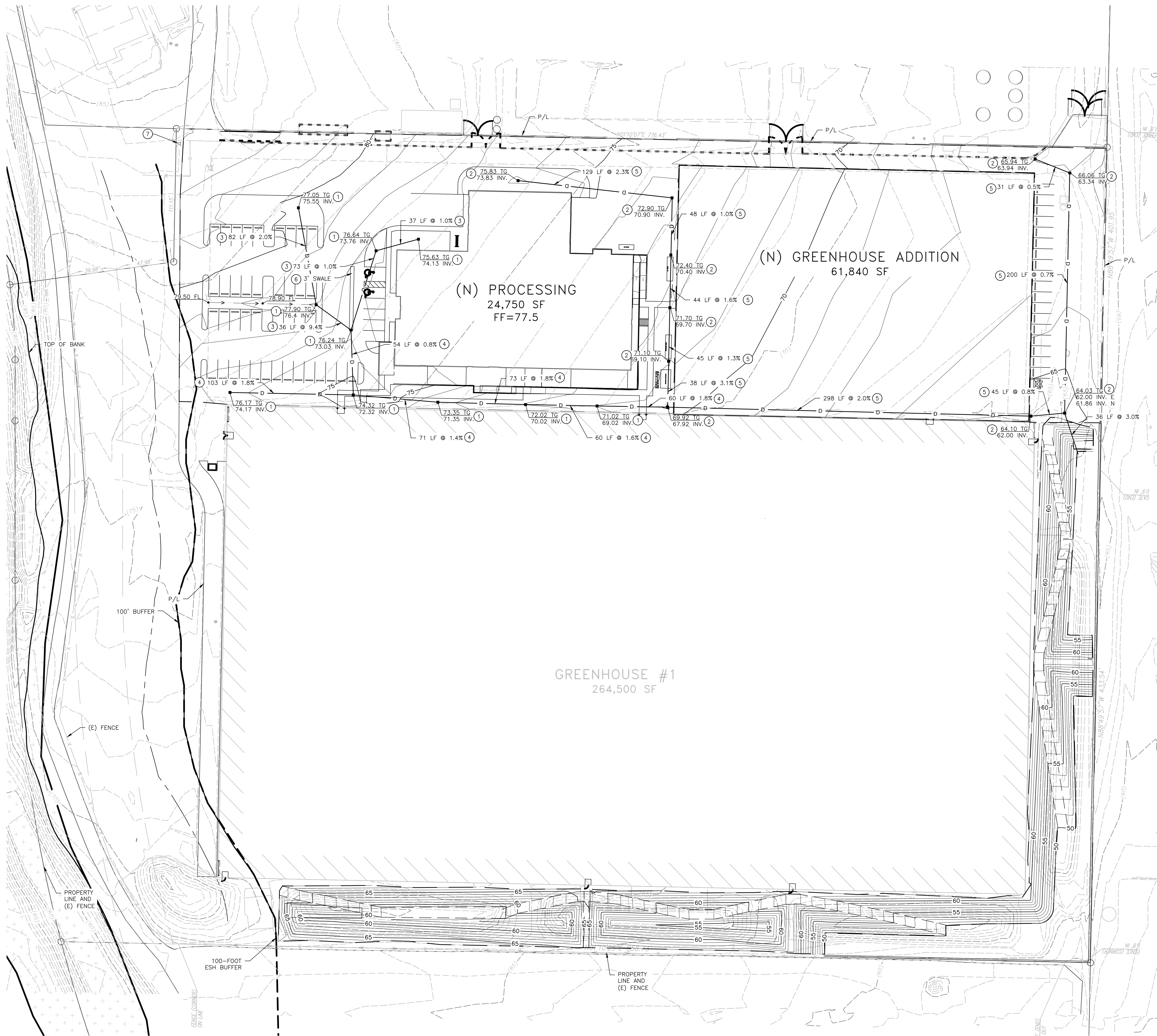

**CONSTRUCTION NOTES**

- 1 INSTALL 12" X 12" PRECAST CONCRETE CATCH BASIN BY MID-STATE CONCRETE PRODUCTS OR APPROVED EQUAL. SEE SHEET C10.
- 2 INSTALL 18" X 18" PRECAST CONCRETE CATCH BASIN BY MID-STATE CONCRETE PRODUCTS OR APPROVED EQUAL. SEE SHEET C10.
- 3 INSTALL 6" PVC SDR-35 STORM DRAIN, TRENCH BACKFILL PER COUNTY OF SANTA BARBARA STANDARD DETAIL 2-020, SHEET C10.
- 4 INSTALL 8" PVC SDR-35 STORM DRAIN, TRENCH BACKFILL PER COUNTY OF SANTA BARBARA STANDARD DETAIL 2-020, SHEET C10.
- 5 INSTALL 12" PVC SDR-35 STORM DRAIN, TRENCH BACKFILL PER COUNTY OF SANTA BARBARA STANDARD DETAIL, SHEET C10.
- 6 CONSTRUCT CONCRETE SWALE PER DETAIL B, SHEET C10. WIDTH PER PLAN.
- 7 INSTALL NEW FIRE HYDRANT. SEE MASTER FIRE PLAN FOR DETAILS.

**NOTE:**  
 BFE WAS DETERMINED TO BE 2.5' ABOVE HIGHEST ADJACENT GRADE. THE HIGHEST ADJACENT GRADE WAS DETERMINED TO BE 77.5'. THEREFORE THE BFE IS 80.0'. SINCE THE FINISHED FLOOR ELEVATION IS BELOW BFE THE BUILDING WILL BE DRY FLOOD PROOFED UP TO THE BFE OF 80.0'.

APPROVED: \_\_\_\_\_ DATE \_\_\_\_\_  
 AGENCY REPRESENTATIVE \_\_\_\_\_

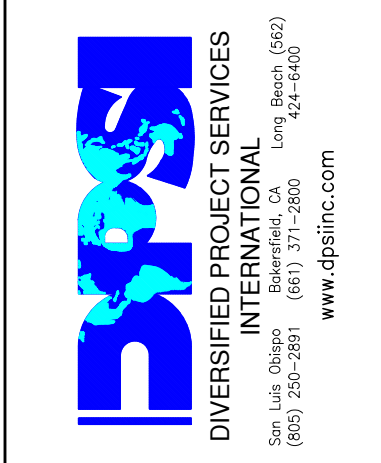
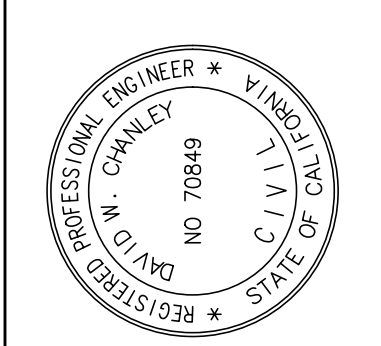

APP	REVISIONS	DATE	REV	BY
	ISSUED FOR SUBMITTAL	10/07/21	A	

**UTILITY PLAN**  
**SLO CULTIVATION**  
 3861 FOOTHILL ROAD  
 CARPINTERIA, CA

SHEET **C7**  
 OF 8 SHEETS  
 PROJECT: 201056  
 PLOTTED: 2021-10-11

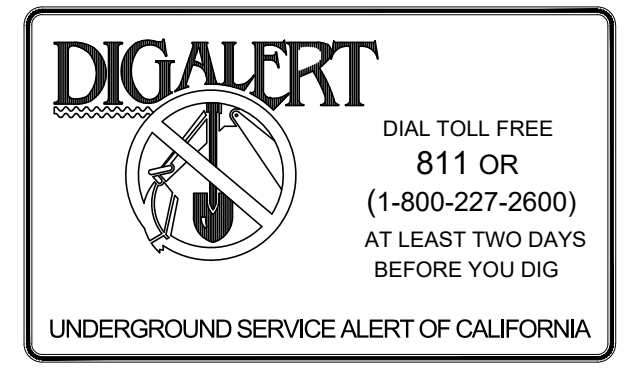

THE DELIVERY OF THIS DRAWING SHOULD NOT BE CONSTRUED TO PROVIDE AN EXPRESS WARRANTY OR GUARANTEE TO ANYONE THAT ALL DIMENSIONS AND DETAILS ARE EXACT OR TO INDICATE THAT THE USE OF THIS DRAWING IMPLIES THE REVIEW AND APPROVAL OF DPSI OF ANY FUTURE USE. ANY USE OF THIS INFORMATION IS AT THE SOLE RISK OF THE USER.

N:\201056\07\_CAD\DWG\CD-DWG\CD-DRWG\CD101056-UPROD.DWG

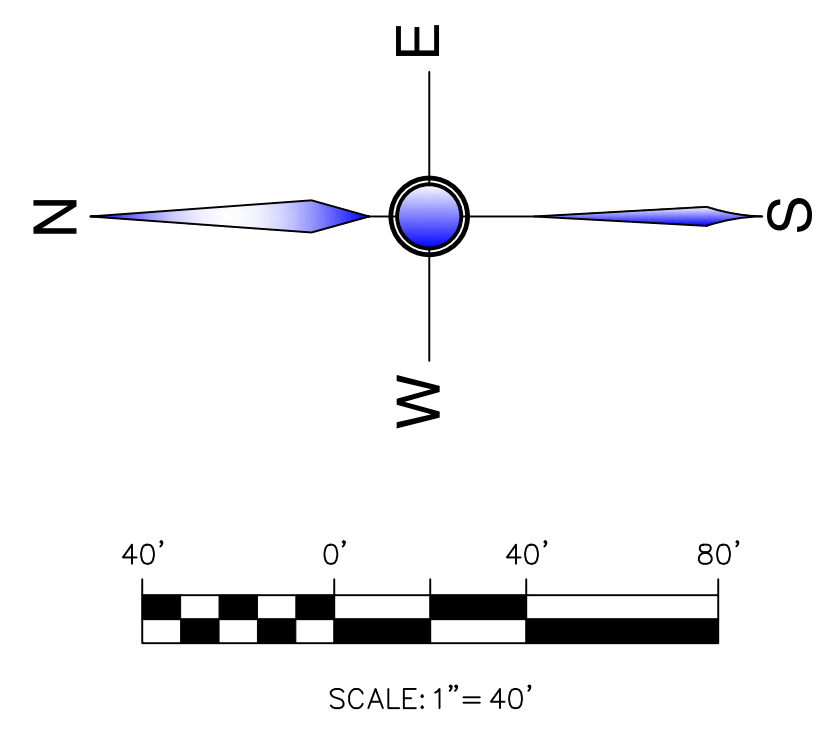
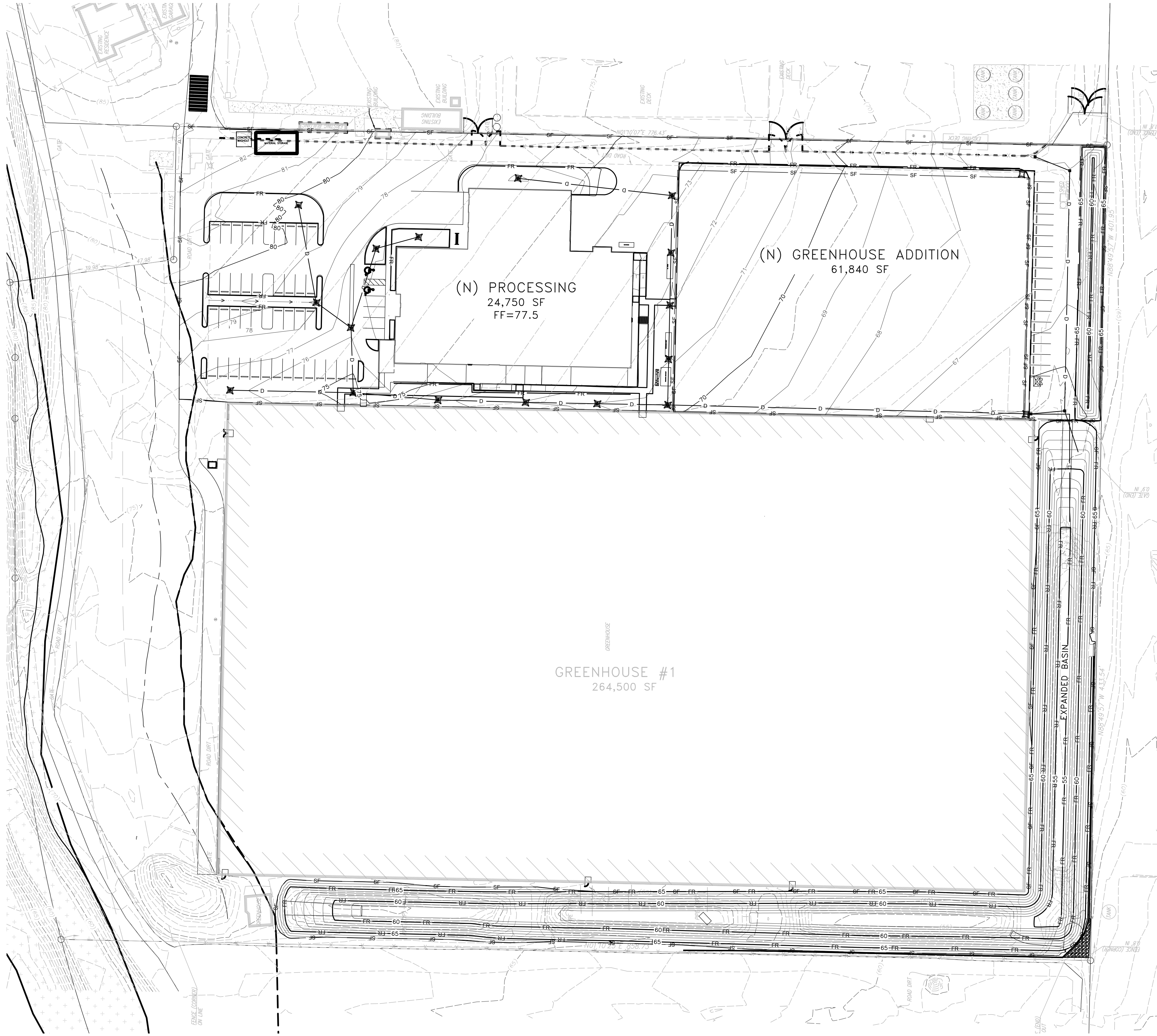

**LEGEND**

- INSTALL SILT FENCING PER CASQA DETAIL SE-1
- INSTALL FIBER ROLLS PER CASQA DETAIL SE-5
- INSTALL TRACKOUT PAD PER CASQA DETAIL TC-1
- INSTALL CONCRETE WASHOUT PER CASQA DETAIL WM-8
- INSTALL MATERIAL STORAGE PER CASQA DETAIL WM-1 AND FACT SHEET SC-31.
- INSTALL STORM DRAIN INLET PROTECTION PER CASQA DETAIL SE-10.

**NOTE:**  
 BFE WAS DETERMINED TO BE 2.5' ABOVE HIGHEST ADJACENT GRADE. THE HIGHEST ADJACENT GRADE WAS DETERMINED TO BE 77.5'. THEREFORE THE BFE IS 80.0'. SINCE THE FINISHED FLOOR ELEVATION IS BELOW BFE THE BUILDING WILL BE DRY FLOOD PROOFED UP TO THE BFE OF 80.0'.

GREENHOUSE #1  
 264,500 SF

(N) GREENHOUSE ADDITION  
 61,840 SF

(N) PROCESSING  
 24,750 SF  
 FF=77.5

**EROSION CONTROL PLAN  
 SLO CULTIVATION**  
 3861 FOOTHILL ROAD  
 CARPINTERIA, CA

SHEET **C8**  
 OF 8 SHEETS  
 PROJECT: 201056  
 PLOTTED: 2023-10-11

**DIGALERT**  
 DIAL TOLL FREE  
 811 OR  
 (1-800-227-2600)  
 AT LEAST TWO DAYS  
 BEFORE YOU DIG  
 UNDERGROUND SERVICE ALERT OF CALIFORNIA

THE DELIVERY OF THIS DRAWING SHOULD NOT BE CONSTRUED TO PROVIDE AN EXPRESS WARRANTY OR GUARANTEE TO ANYONE THAT ALL DIMENSIONS AND DETAILS ARE EXACT OR TO INDICATE THAT THE USE OF THIS DRAWING IMPLIES THE REVIEW AND APPROVAL OF DPSP OF ANY FUTURE USE. ANY USE OF THIS INFORMATION IS AT THE SOLE RISK OF THE USER.

APPROVED:

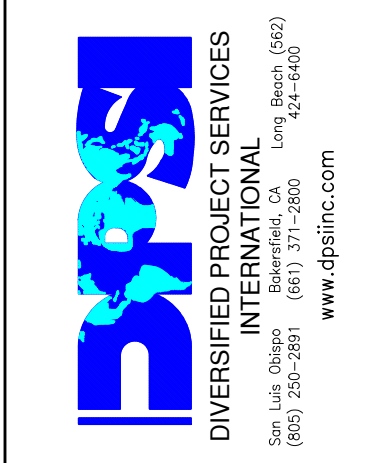
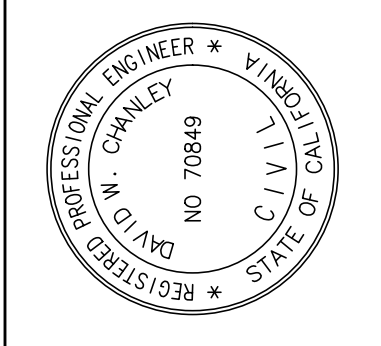

DATE	REV	REVISIONS	APP
10/07/21	A	ISSUED FOR SUBMITTAL	

DATE \_\_\_\_\_  
 AGENCY REPRESENTATIVE \_\_\_\_\_



**Silt Fence SE-1**

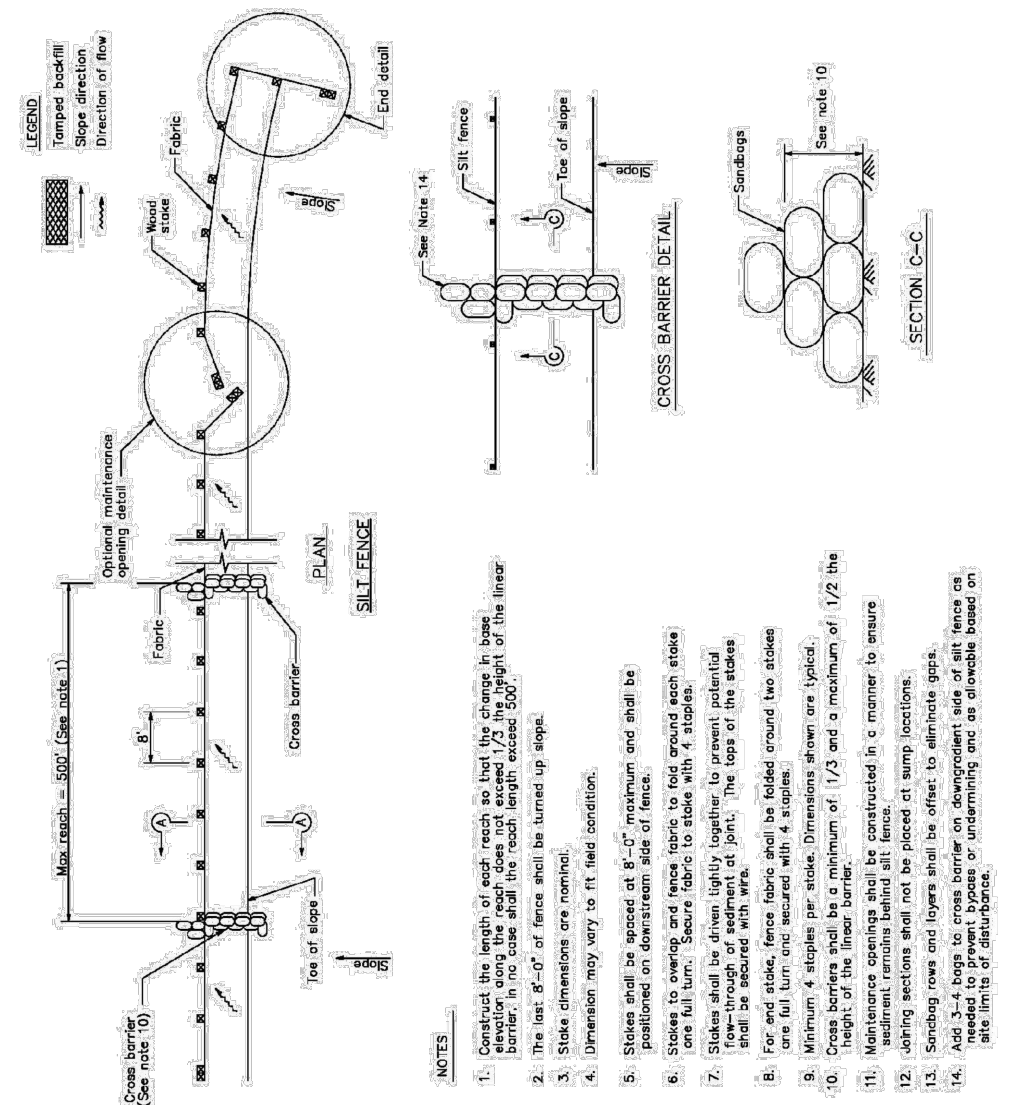

July 2012 California Stormwater BMP Handbook Portal Construction www.casqa.org 7 of 9

**Silt Fence SE-1**

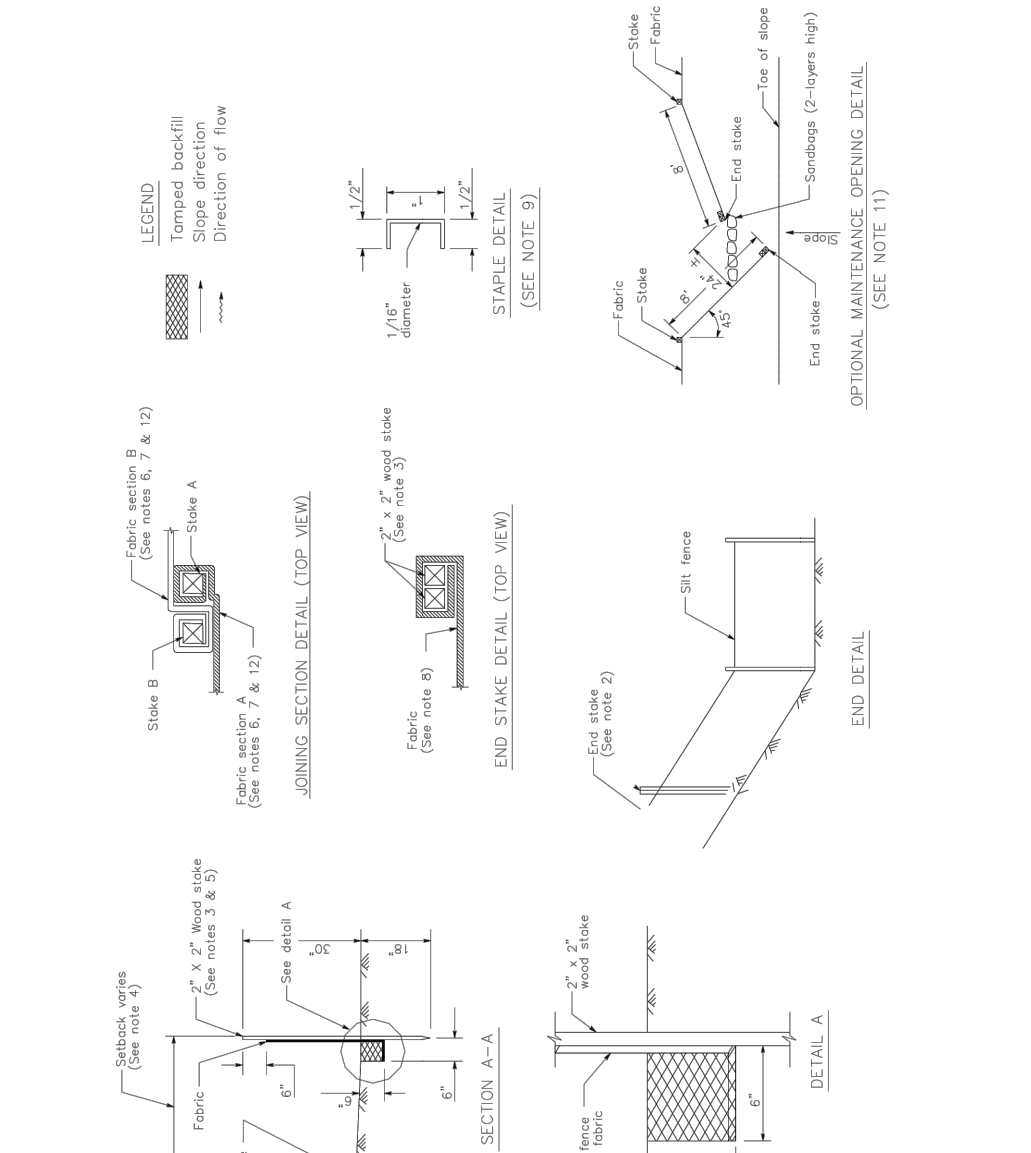

July 2012 California Stormwater BMP Handbook Portal Construction www.casqa.org 8 of 9

**Fiber Rolls SE-5**

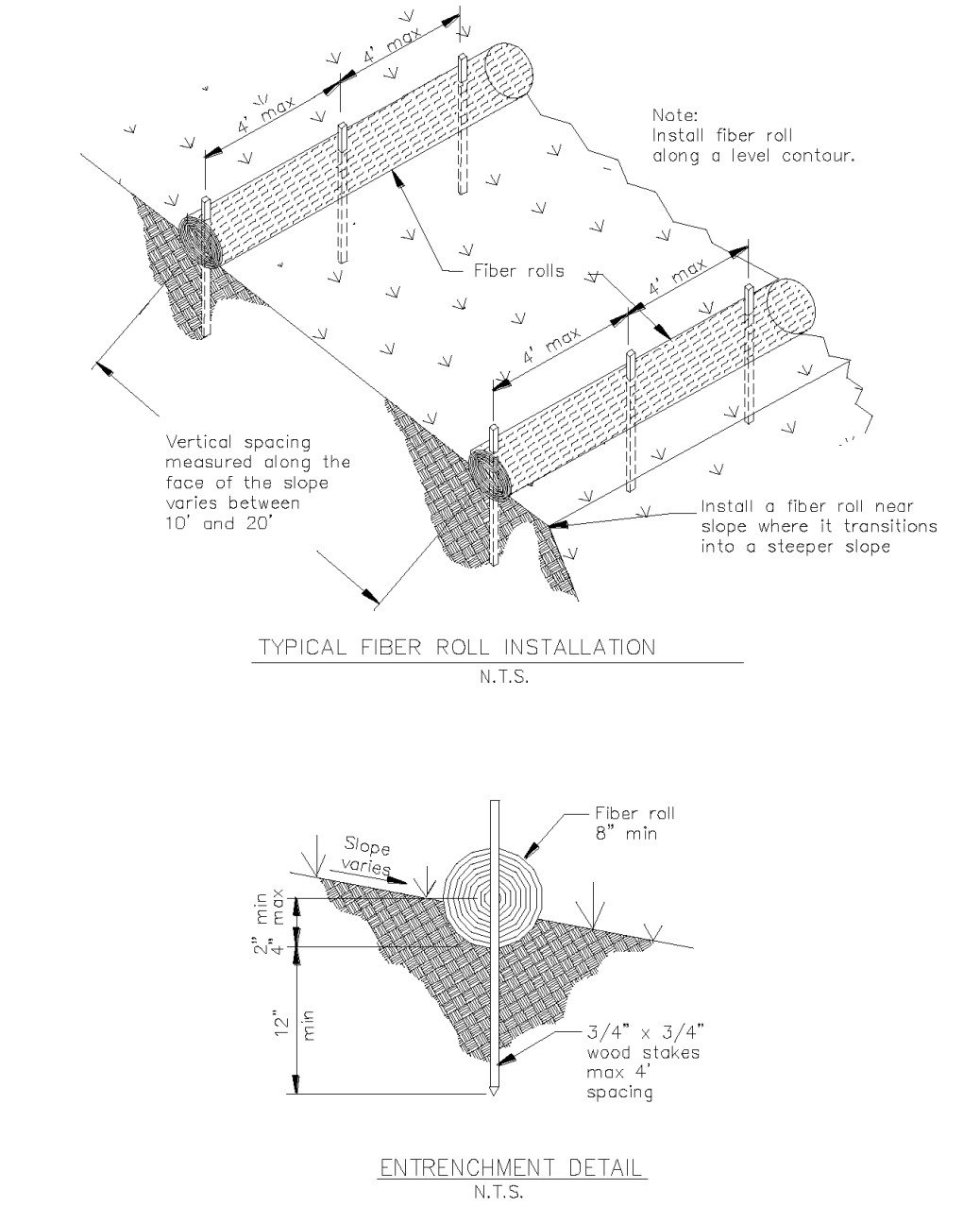

May 2011 California Stormwater BMP Handbook Portal Construction www.casqa.org 5 of 5

**Storm Drain Inlet Protection SE-10**

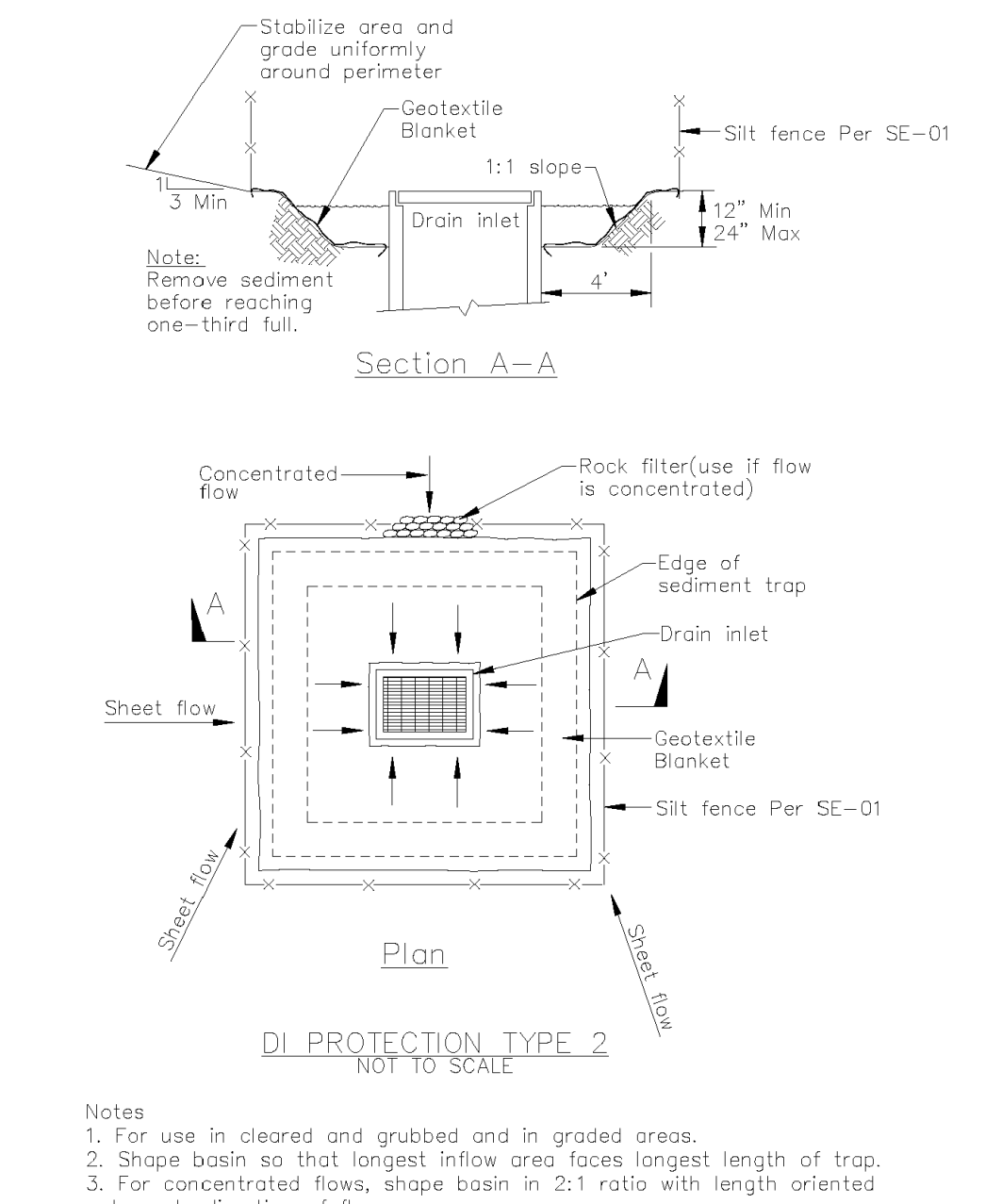

November 2009 California Stormwater BMP Handbook Construction www.casqa.org 8 of 10

**Stabilized Construction Entrance/Exit TC-1**

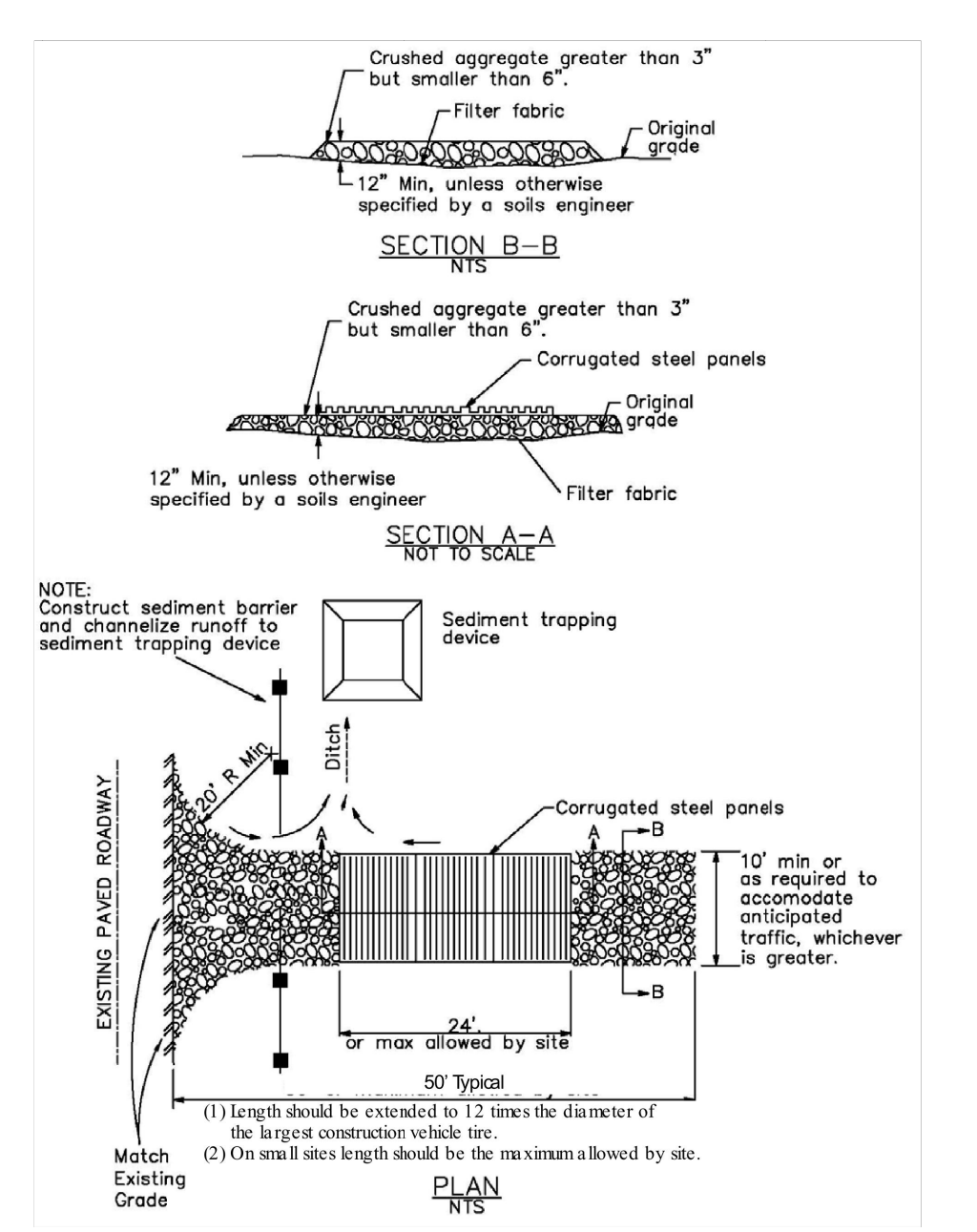

July 2012 California Stormwater BMP Handbook Construction www.casqa.org 6 of 6

**Concrete Waste Management WM-8**

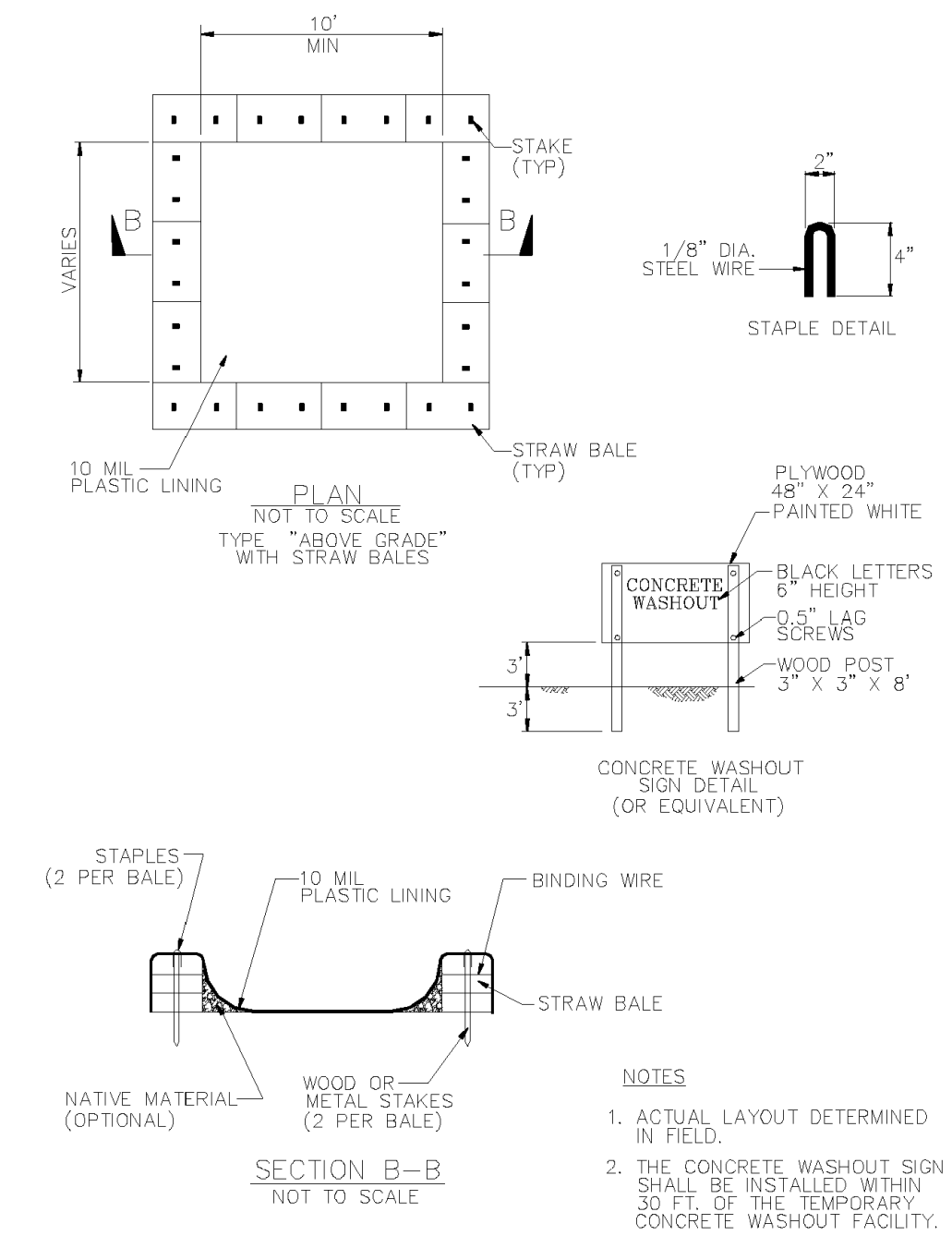

November 2009 California Stormwater BMP Handbook Construction www.casqa.org 7 of 7

APPROVED: \_\_\_\_\_ DATE \_\_\_\_\_  
AGENCY REPRESENTATIVE \_\_\_\_\_

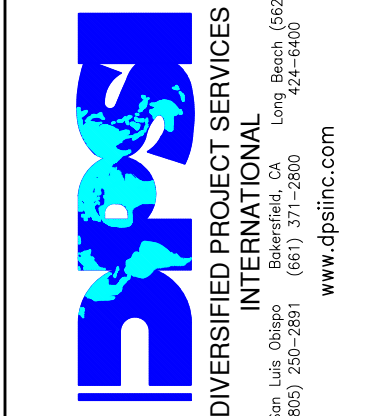
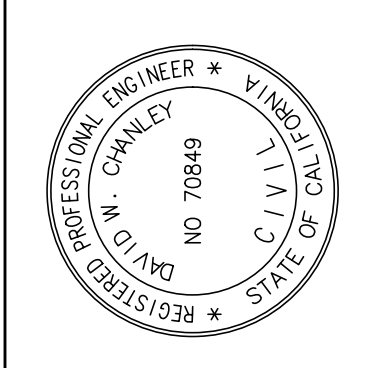

REV	DATE	REVISIONS	APP
10/07/21	A	ISSUED FOR SUBMITTAL	

**EROSION CONTROL DETAILS**  
**SLO CULTIVATION**  
3861 FOOTHILL ROAD  
CARPINTERIA, CA

SHEET **C9** OF 8 SHEETS  
PROJECT: 201056  
PLUMED 2021-05-11

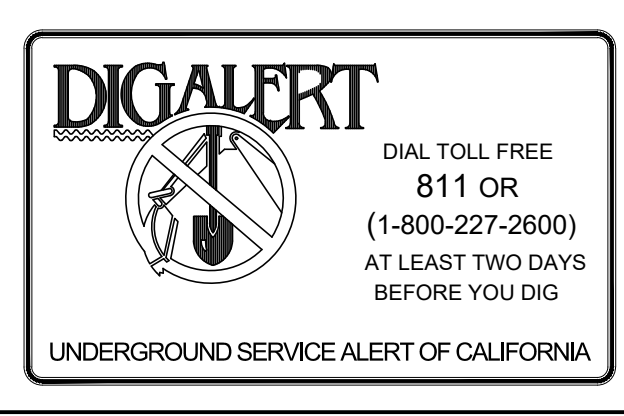

THE DELIVERY OF THIS DRAWING SHOULD NOT BE CONSTRUED TO PROVIDE AN EXPRESS WARRANTY OR GUARANTEE TO ANYONE THAT ALL DIMENSIONS AND DETAILS ARE EXACT OR TO INDICATE THAT THE USE OF THIS DRAWING IMPLIES THE REVIEW AND APPROVAL OF DPSI OF ANY FUTURE USE. ANY USE OF THIS INFORMATION IS AT THE SOLE RISK OF THE USER.

N:\201056\DOT\_CD\DWG\LS-SHEETS\2-CORNER\_CED1056-05001.DWG

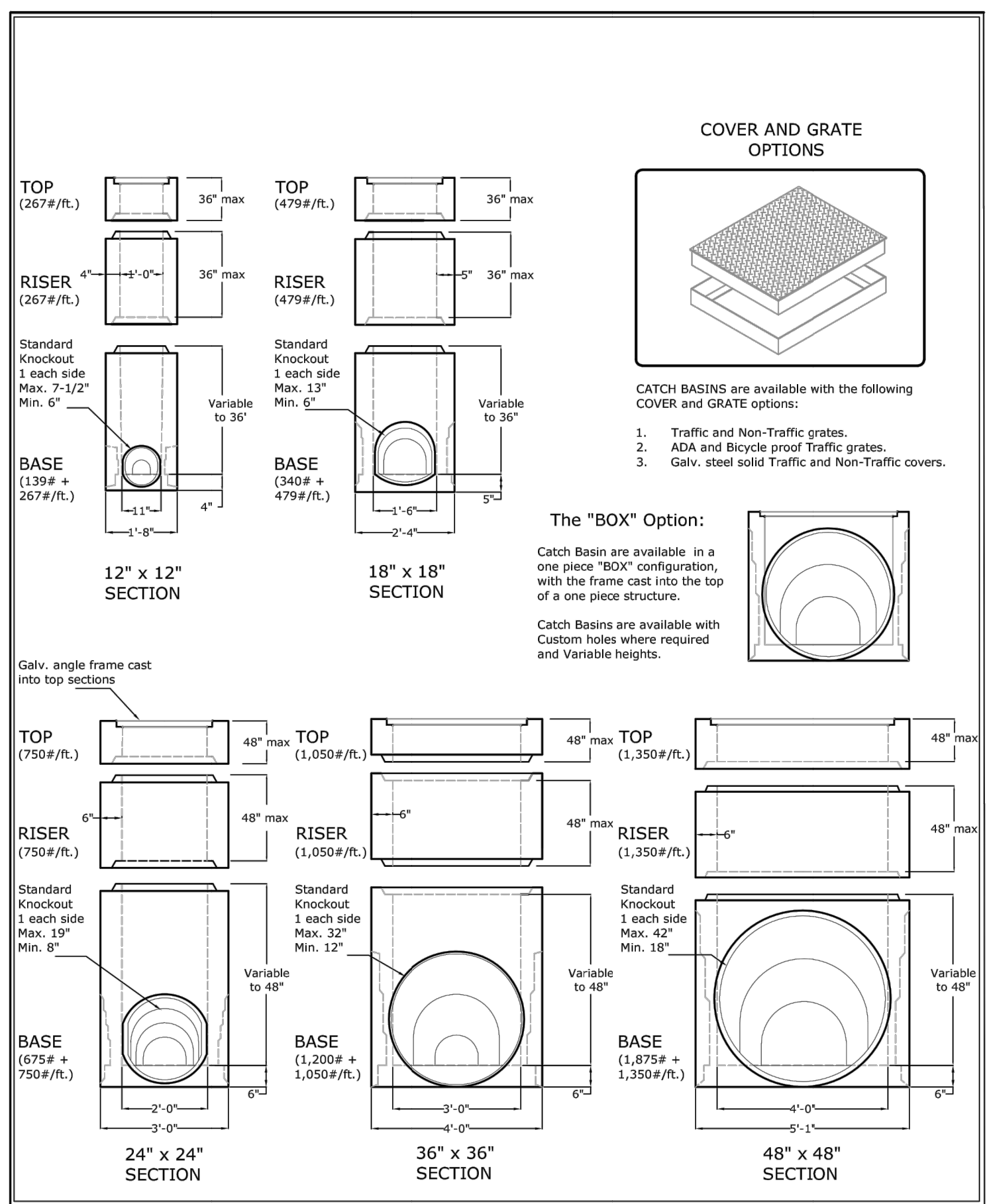

**MD STATE Concrete Products**  
Santa Maria, Ca

1688 E. DONOVAN RD., STE. C  
SANTA MARIA, CA 93404  
TEL: (805) 928-2875  
FAX: (805) 928-2874  
www.mdstateconcrete.com

**SQUARE CATCH BASINS**

REV. 08/08

- (REFER TO 1-010 FOR ADDITIONAL NOTES)
- CONCRETE FOR SIDEWALKS AND CURB RAMPS SHALL BE CALTRANS CLASS 3 OR BETTER WITH 25% FLY-ASH IN THE MIX DESIGN. WHEN CONCRETE IS ALSO BEING USED FOR DRIVEWAYS AND GUTTERS, IT SHALL BE CLASS 2 OR BETTER.
  - THICKNESS OF SIDEWALKS SHALL BE 4" MINIMUM, AND THE TRANSVERSE SLOPE SHALL BE 2% MAX DRAINING TOWARD THE CURB. MINIMUM WIDTH SHALL BE 4'. REFER TO TABLES IN 5-040.
  - SUBGRADE MATERIAL SHALL BE COMPACTED TO 90% OF MAXIMUM DENSITY FOR A 0.50' DEPTH IN EXPANSIVE SOILS AND SOILS WHICH CANNOT REACH 90% RELATIVE COMPACTION, A 0.35' LAYER OF CALTRANS CLASS 4 BASE OR BETTER SHALL BE PLACED AND COMPACTED TO 90% RELATIVE COMPACTION.
  - ADA COMPATIBLE SLOPES, DETECTABLE WARNING SURFACES, AND GROoved BORDERS AT GRADE BREAKS SHALL BE PROVIDED WHERE REQUIRED BY ALL CURRENT REGULATIONS.
  - EXPANSION JOINTS SHALL BE MADE WITH 1/2" EXPANSION PAPER AND PLACED AT THE BEGINNING AND END OF EACH CURB RETURN, ON EACH SIDE OF DRAINAGE STRUCTURES SUCH AS DROP INLETS, AT UTILITY VAULTS AND POLES, EVERY 200' OF LENGTH, AND AT OTHER PLACES AS DIRECTED BY THE COUNTY ENGINEER.
  - WEAKENED-PLANE JOINTS SHALL BE TOOLED 1-1/2" DEEP ON SIDEWALKS, CURBS AND GUTTERS AT INTERVALS OF NO MORE THAN 10', AND AT BOTH SIDES OF METER BOXES AND PULL BOXES. JOINTS IN ADJACENT CURBS AND SIDEWALKS SHALL BE ALIGNED.
  - SCORELINES SHALL BE TOOLED 1/4" DEEP ON SIDEWALKS MIDWAY BETWEEN WEAKENED-PLANE JOINTS. ON CURB RETURNS, THEY SHALL BE PLACED SO AS TO CONTINUE THE CURB LINE THROUGH THE RAMP.
  - UTILITY BOXES AND VAULTS SHALL NOT BE LOCATED IN SIDEWALKS WHERE POSSIBLE. THERE SHALL BE A MINIMUM OF 4' SIDEWALK CLEARANCE AROUND ANY SIGNS, POLES, OR OTHER OBSTRUCTIONS.

COUNTY OF SANTA BARBARA, CA - DEPARTMENT OF PUBLIC WORKS - TRANSPORTATION

APPROVED BY: *[Signature]* 11/1/2011

5-010 GENERAL SIDEWALK NOTES

REVISION DATES: \_\_\_\_\_ DATE: \_\_\_\_\_

NOTES (REFER TO 5-010 FOR ADDITIONAL NOTES)

- THE WIDTH OF THE SIDEWALKS (NOT INCLUDING THE CURB) SHALL BE AS SHOWN IN TABLE A OR B. SIDEWALKS FRONTING COMMERCIAL DEVELOPMENTS SHALL EXTEND FROM THE BACK OF THE CURB TO 6" FROM THE RIGHT-OF-WAY LINE.
- TRANSVERSE EXPANSION JOINTS SHOULD CONTINUE THROUGH THE ADJACENT CURB AND GUTTER.
- WEAKENED-PLANE JOINTS SHALL BE PROVIDED AT INTERVALS OF NOT MORE THAN 10' ON SIDEWALKS AND CURBS/GUTTERS. WHERE SIDEWALKS ABUT THE CURB, THE WEAKENED-PLANE JOINT SHALL BE CONTINUOUS THROUGH BOTH.
- A SCORELINE SHALL BE PLACED MIDWAY BETWEEN WEAKENED-PLANE JOINTS. WHERE THE SIDEWALK WIDTH EXCEEDS 6', A LONGITUDINAL SCORELINE SHALL BE TOOLED AT THE SIDEWALK CENTERLINE.
- ADDITIONAL SIDEWALK WIDTH MAY BE NEEDED TO MAINTAIN A MINIMUM OF 4' CLEAR SIDEWALK AROUND EXISTING OBSTRUCTIONS SUCH AS UTILITY POLES.

PLAN A - SIDEWALK WITHOUT PARKWAY

PLAN B - SIDEWALK WITH PARKWAY

TABLE A

R/W WIDTH	STD DTL	MINIMUM WIDTH	COMMERCIAL WIDTH	WIDTH	STANDARD CY/LF	MONOLITHIC CY/LF
NAILER	6'-07 1/2"	5'	9.5'	9.5'	0.116	0.124
6"	6'-03 1/2"	5'	9.5'	6'	0.073	0.082
56"	6'-03 1/2"	5'	9.5'	5'	0.061	0.069
RURAL	6'-03 1/2"	4'	9.5'	4'	0.049	0.057

TABLE B

R/W WIDTH	STD DTL	MINIMUM WIDTH	COMMERCIAL WIDTH	WIDTH	STANDARD CY/LF
NAILER	6'-07 1/2"	5'	9.5'	9.5'	0.116
6"	6'-03 1/2"	5'	9.5'	6'	0.061
56"	6'-03 1/2"	5'	9.5'	5'	0.061
RURAL	6'-03 1/2"	4'	9.5'	4'	0.049

COUNTY OF SANTA BARBARA, CA - DEPARTMENT OF PUBLIC WORKS - TRANSPORTATION

APPROVED BY: *[Signature]* 11/1/2011

5-040 SIDEWALK DETAILS

REVISION DATES: \_\_\_\_\_ DATE: \_\_\_\_\_

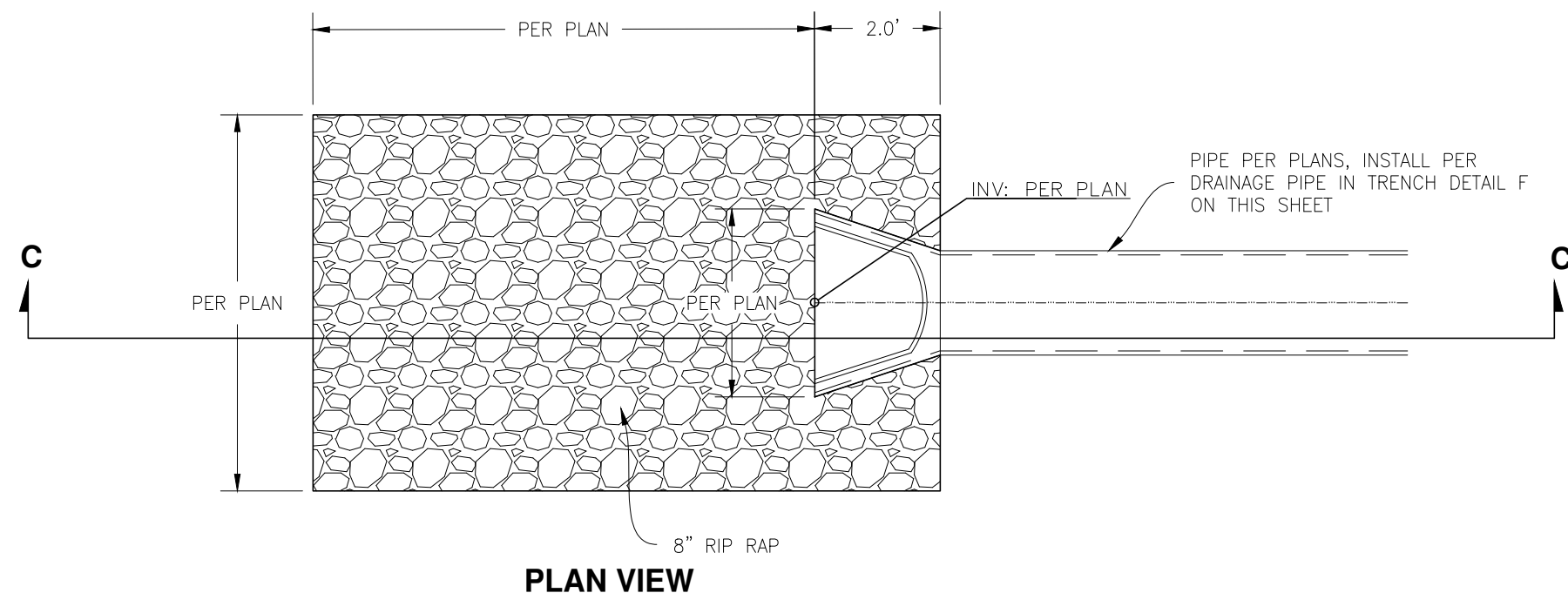

**F DRAINAGE VELOCITY DISSIPATOR** N.T.S.

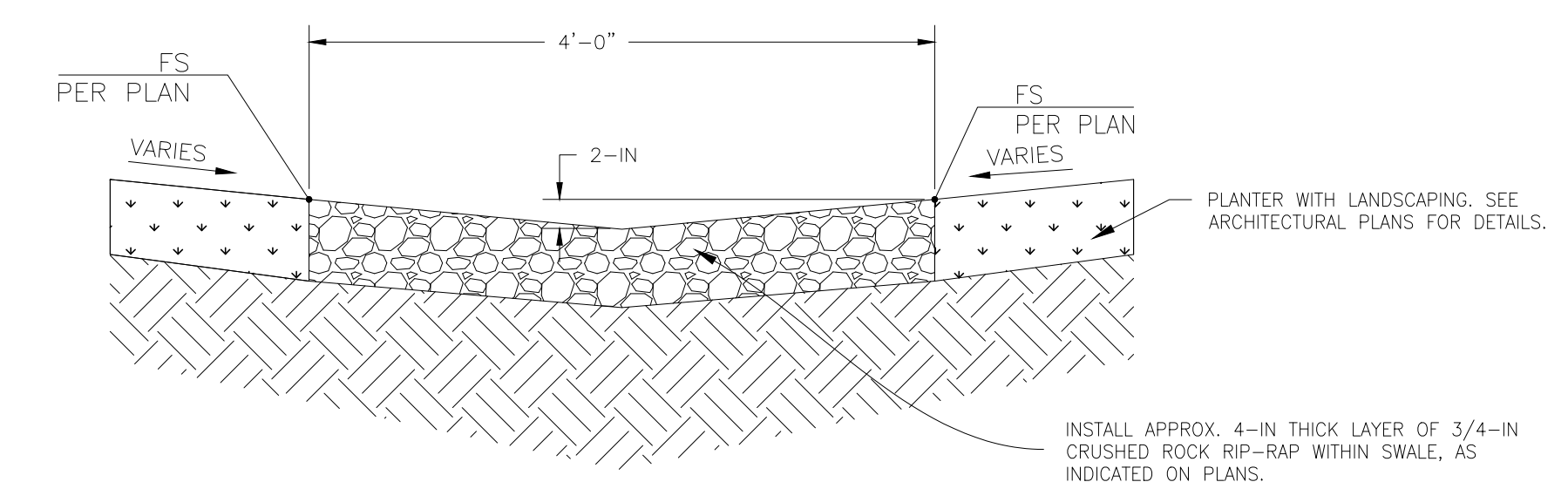

**A 4' GRAVEL SWALE** N.T.S.

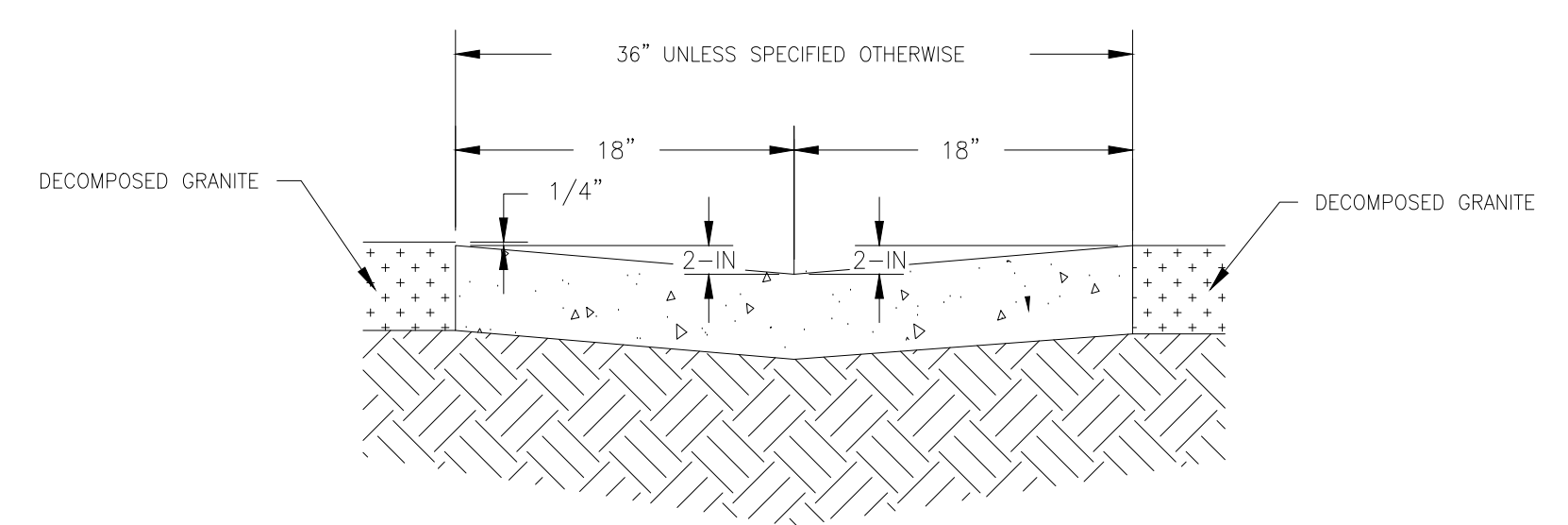

**B 3' CONCRETE SWALE** N.T.S.

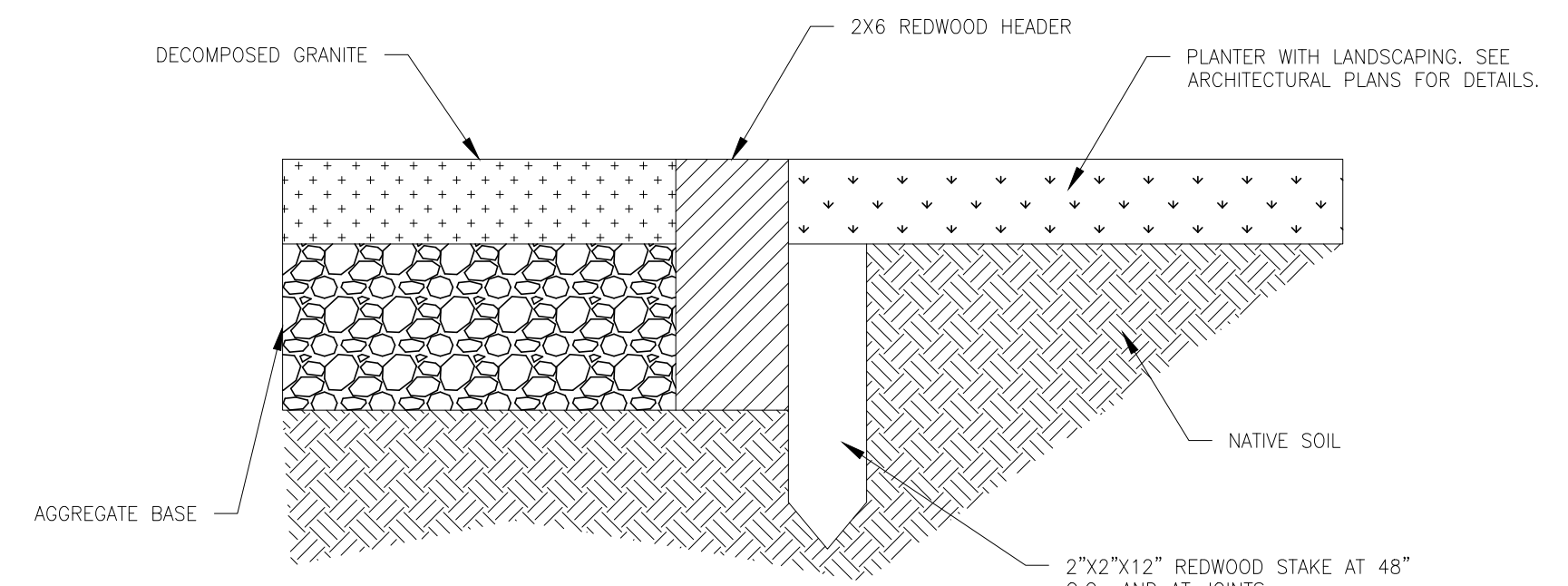

**C REDWOOD HEADER** N.T.S.

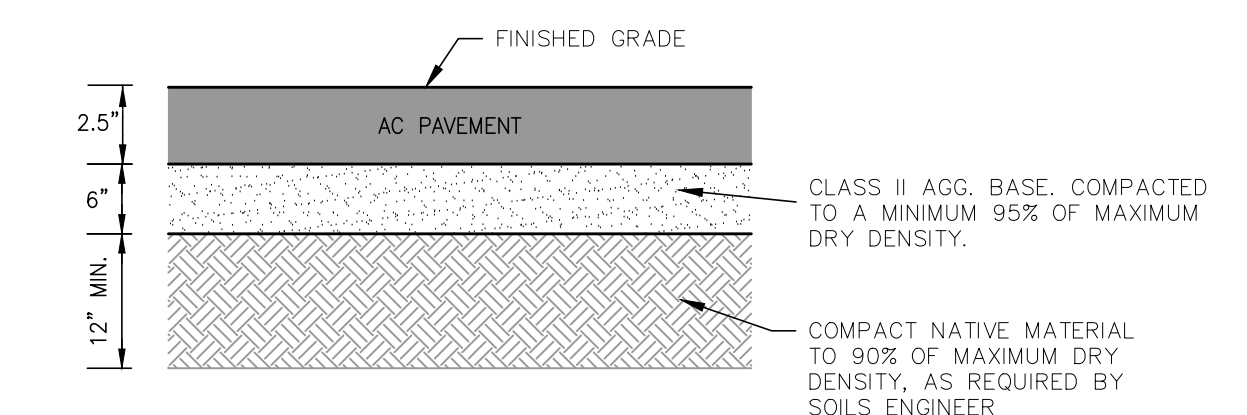

**D ASPHALT PAVEMENT SECTION** N.T.S.

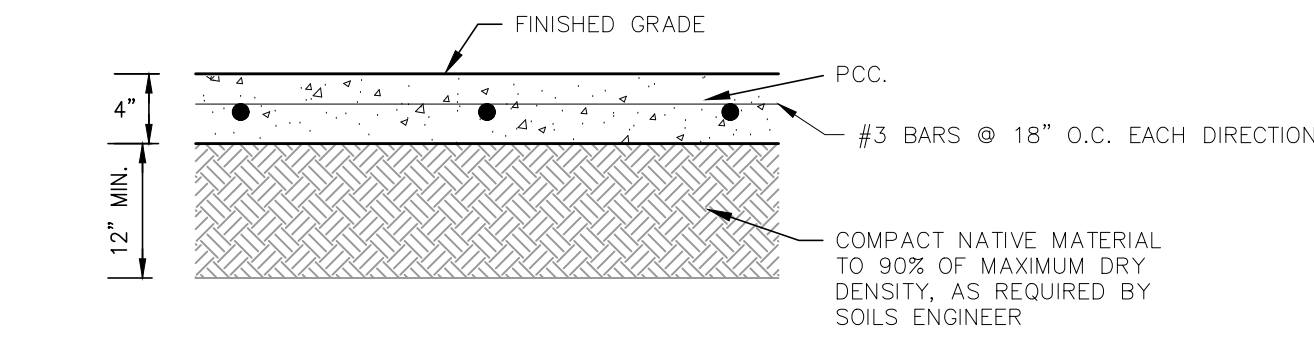

**E SIDEWALK SECTION** N.T.S.

- NOTES (REFER TO 2-010 FOR ADDITIONAL NOTES)
- TRENCH WIDTH SHALL BE SUFFICIENT TO FULLY ENCLOSE THE PIPE AND ALLOW COMPACTION TESTING AT THE SPRING LINE.
  - BEDDING MATERIAL FOR UTILITY TRENCHES SHALL MEET THE STANDARDS OF THE UTILITY COMPANY INVOLVED.
  - BEDDING MATERIAL FOR HDPE, RCP AND CMP SHALL FOLLOW THE MANUFACTURER'S RECOMMENDATIONS AND SHALL BE COMPACTED TO 95% RELATIVE COMPACTION. FILL MUST BE PLACED IN LIFTS NO LARGER THAN 8" TO FACILITATE COMPACTION. FOR CMP PIPE, THE BEDDING MATERIAL SHALL BE TESTED FOR A NEUTRAL pH.
  - THE THICKNESS OF THE LAYER OF BEDDING UNDER THE PIPE SHALL BE AT LEAST 4" OR 10% OF THE PIPE DIAMETER, WHICHEVER IS LARGER.
  - BEDDING MATERIAL SHALL COMPLETELY COVER THE PIPE TO A MINIMUM HEIGHT OF 6" AFTER COMPACTION.
  - CARE MUST BE TAKEN TO PLACE THE BEDDING EVENLY UNDER THE LENGTH OF THE PIPE TO ASSURE ADEQUATE SUPPORT. COMPACTION TESTING IS REQUIRED AT THE SPRINGLINE OF THE PIPE WHEN SAND IS USED AS BEDDING MATERIAL.
  - BACKFILL MATERIAL SHALL MEET THE REQUIREMENTS OF SBCD STD 2-030 AND 2-040
  - SEE NOTE 2 ON 2-010

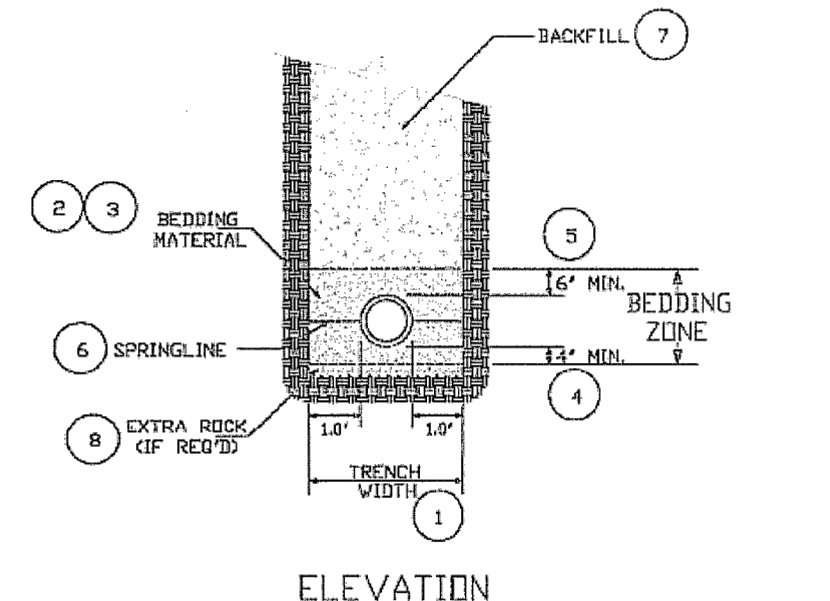

COUNTY OF SANTA BARBARA, CA - DEPARTMENT OF PUBLIC WORKS - TRANSPORTATION

APPROVED BY: *[Signature]* 11/1/2011

2-020 PIPE BEDDING DETAILS

REVISION DATES: \_\_\_\_\_ DATE: \_\_\_\_\_

**DIGALERT**  
DIAL TOLL FREE 811 OR (1-800-227-2600) AT LEAST TWO DAYS BEFORE YOU DIG  
UNDERGROUND SERVICE ALERT OF CALIFORNIA

THE DELIVERY OF THIS DRAWING SHOULD NOT BE CONSTRUED TO PROVIDE AN EXPRESS WARRANTY OR GUARANTEE TO ANYONE THAT ALL DIMENSIONS AND DETAILS ARE EXACT OR TO INDICATE THAT THE USE OF THIS DRAWING IMPLIES THE REVIEW AND APPROVAL OF DIPS OF ANY FUTURE USE. ANY USE OF THIS INFORMATION IS AT THE SOLE RISK OF THE USER.

DATE: \_\_\_\_\_

AGENCY REPRESENTATIVE: \_\_\_\_\_

REGISTERED PROFESSIONAL ENGINEER  
DAVID W. CANALEY  
NO. 70849  
CIVIL  
STATE OF CALIFORNIA

DIVERSIFIED PROJECT SERVICES INTERNATIONAL  
1000 J ST. SUITE 200  
SANTA BARBARA, CA 93101  
TEL: (805) 235-2391 FAX: (805) 235-2392  
www.dpsinc.com

ISSUED FOR SUBMITTAL

10/07/21

DATE

REVISIONS

APP

SHEET

**C10**

PROJECT: 201056

OF 8 SHEETS

PLUMED 2013-10-11

N:\2010\04\07\_CAD\DWG\5-SHEETS\2-DRAWING\CD1056-05002.DWG

**Attachment 3**

**Existing Erosion and Sediment Control  
BMPs and Drainage Diagram**

- Existing Erosion/Sediment BMPs +**
1. Velocity Dissipation Device
  2. Roof Drains
  3. Concrete Outflow Weir
  - 4 - 7. Stormwater Detentions
  8. Material Storage (Fertilizers/Chemicals/Etc)
  9. Cannabis Waste Storage

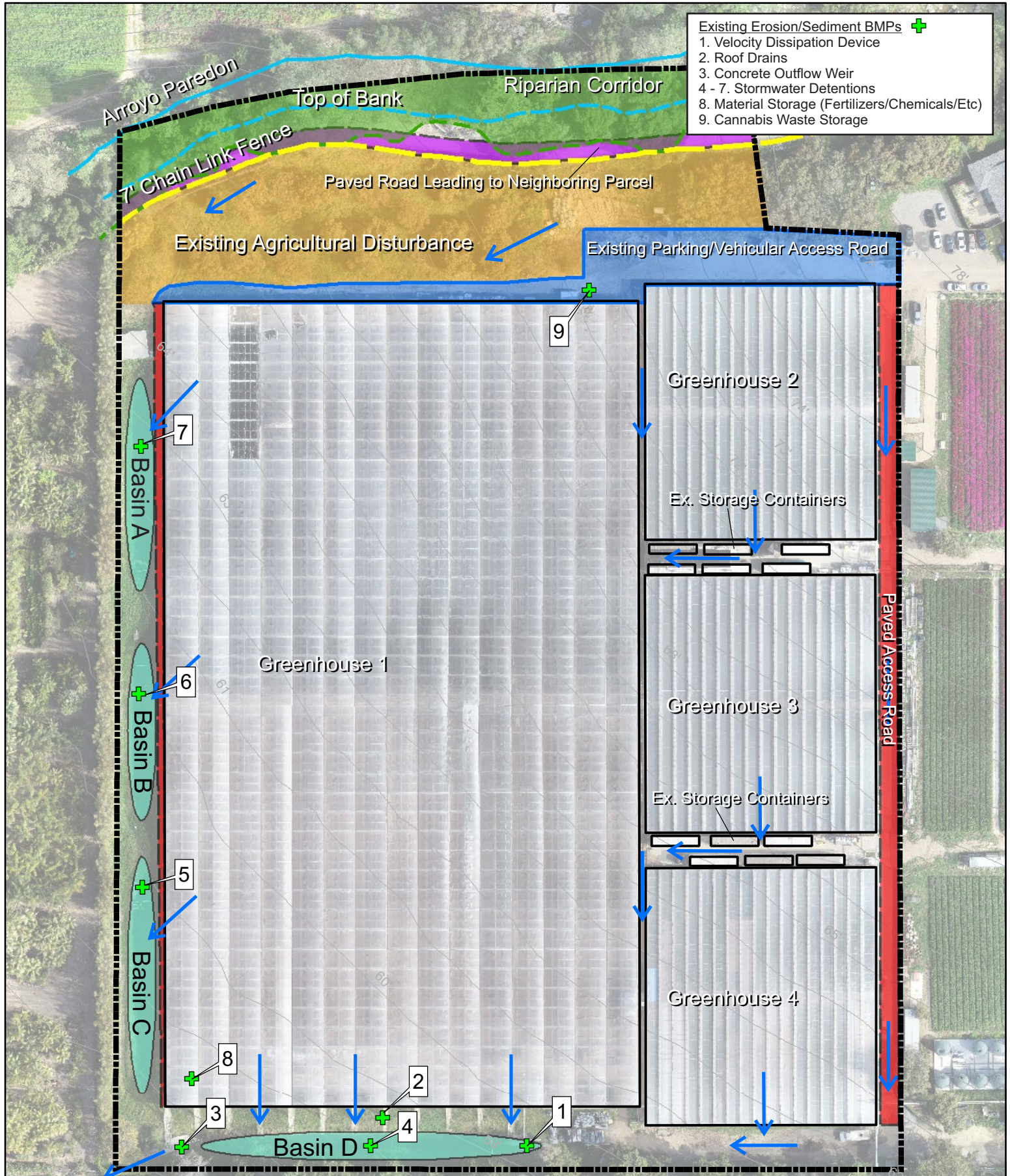

**LEGEND**

Existing - Erosion/Sediment BMPs	Existing Greenhouses Parcel 005-310-024	Existing Storm Water Basins	Existing Storage Containers	Arroyo Paredon TOB	ESH Boundary	Paved Road Leading to Neighboring Parcel	Existing Parking/Vehicular Access Road
Drainage	Existing Paved Road	Arroyo Paredon Centerline	Fenceline	Riparian Corridor	Existing Agricultural Disturbance	5 foot Contours	

PREPARED BY SCS ENGINEERS  
 JANUARY 2021  
 GCS, NAD 83

**SCS ENGINEERS**

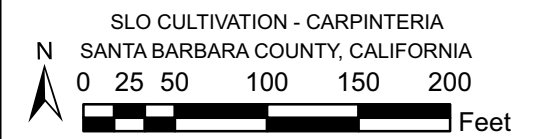

**EXISTING EROSION/SEDIMENT CONTROL BMPs & DRAINAGE**

## **Attachment 4**

# **Proposed Erosion and Sediment Control BMPs**

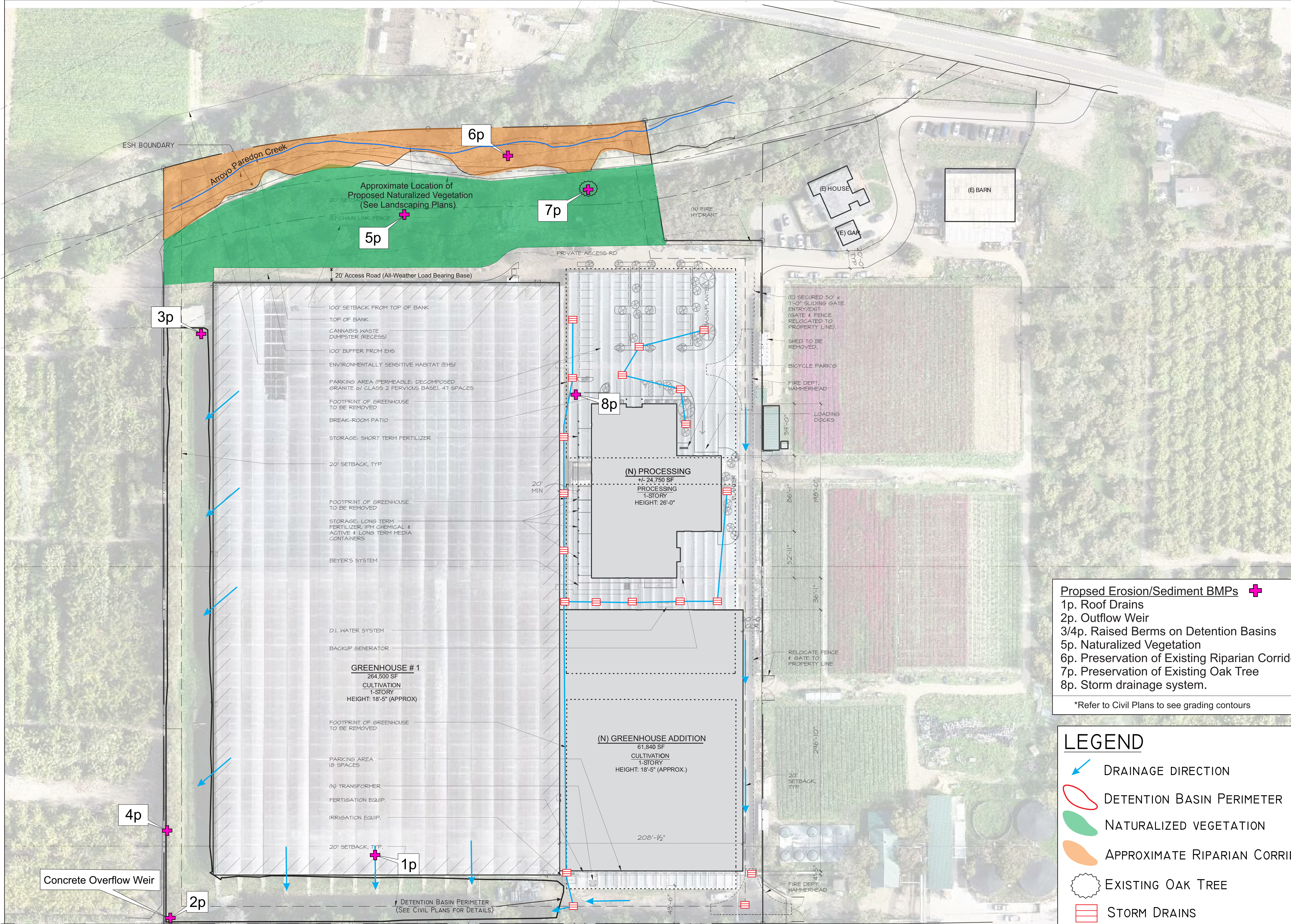

- Proposed Erosion/Sediment BMPs** +
- 1p. Roof Drains
  - 2p. Outflow Weir
  - 3/4p. Raised Berms on Detention Basins
  - 5p. Naturalized Vegetation
  - 6p. Preservation of Existing Riparian Corridor
  - 7p. Preservation of Existing Oak Tree
  - 8p. Storm drainage system.
- \*Refer to Civil Plans to see grading contours

**LEGEND**

- DRAINAGE DIRECTION
- DETENTION BASIN PERIMETER
- NATURALIZED VEGETATION
- APPROXIMATE RIPARIAN CORRIDOR
- EXISTING OAK TREE
- STORM DRAINS

PREPARED BY SCS ENGINEERS  
 OCTOBER 2021  
 MODIFIED FROM BBP ARCHITECTURE SITE PLAN  
 SCS ENGINEERS

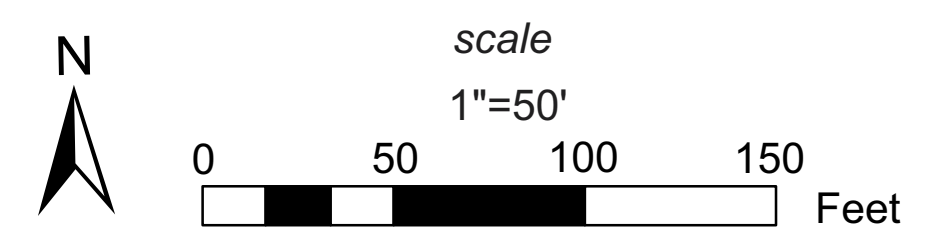

SLO CULTIVATION  
 3861 FOOTHILL ROAD  
 SANTA BARBARA COUNTY, CALIFORNIA

**Attachement 4 - Proposed Erosion/Sediment BMPs**

# Attachment 5 Landscaping Plans

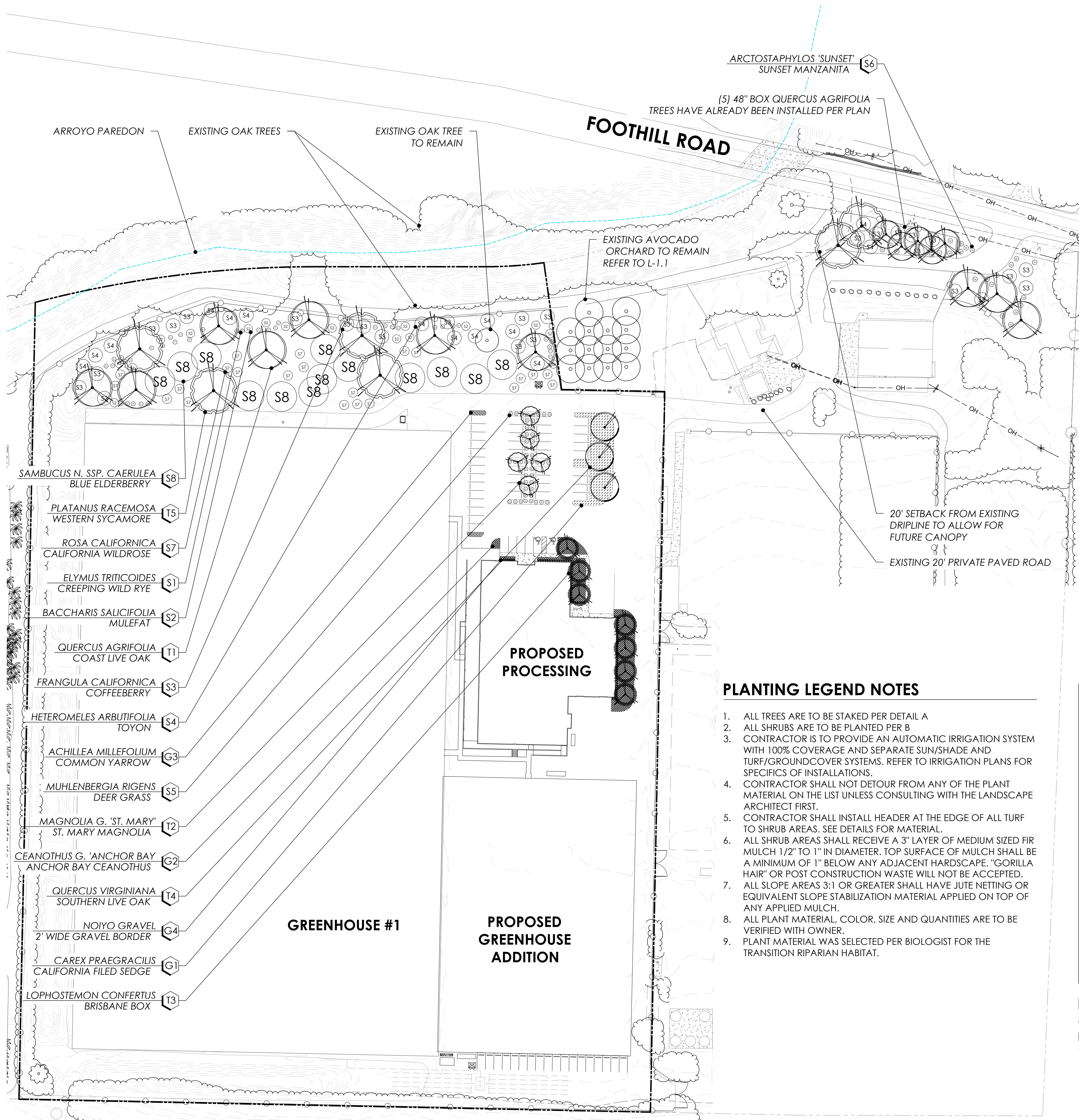

**LANDSCAPE SCREENING PLAN - DETENTION BASIN ENLARGEMENT**

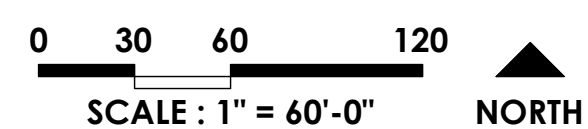

**PLANT LEGEND**

**TREES**

SYMBOL	NAME	COMMENTS	SIZE	WUCOLS	QTY.
T1	QUERCUS AGRIFOLIA COAST LIVE OAK	PLANT PER DETAIL A	48" BOX	V. LOW	15
T2	MAGNOLIA GRANDIFLORA 'ST. MARY' ST. MARY MAGNOLIA	PLANT PER DETAIL A	24" BOX	MED	5
T3	LOPHOSTEMON CONFERTUS BRISBANE BOX	PLANT PER DETAIL A	36" BOX	MED	7
T4	QUERCUS VIRGINIANA SOUTHERN LIVE OAK	PLANT PER DETAIL A	36" BOX	MED	3
T5	PLATANUS RACEMOSA WESTERN SYCAMORE	PLANT PER DETAIL A REFER TO PLANT LEGEND NOTE #9	36" BOX	MED	6

**SHRUBS**

SYMBOL	NAME	COMMENTS	SIZE	WUCOLS	QTY.
S1	ELYMUS TRITICOIDES CREEPING WILD RYE	PLANT PER DETAIL B	1 GAL.	LOW	38
S2	BACCHARIS SALICIFOLIA MULEFAT	PLANT PER DETAIL B	1 GAL.	LOW	15
S3	FRANGULA CALIFORNICA COFFEE BERRY	PLANT PER DETAIL B	5 GAL.	V. LOW	26
S4	HETEROMELES ARBUTIFOLIA TOYON	PLANT PER DETAIL B	5 GAL.	V. LOW	14
S5	MUHLENBERGIA RIGENS DEER GRASS	PLANT PER DETAIL B	5 GAL.	LOW	46
S6	ARCTOSTAPHYLOS 'SUNSET' SUNSET MANZANITA	PLANT PER DETAIL B	5 GAL.	LOW	23
S7	ROSA CALIFORNICA CALIFORNIA WILDROSE	PLANT PER DETAIL B REFER TO PLANT LEGEND NOTE #9	5 GAL.	LOW	23
S8	SAMBUCUS NIGRA SPP. CAERULEA BLUE ELDERBERRY	PLANT PER DETAIL B REFER TO PLANT LEGEND NOTE #9	5 GAL.	LOW	13

**GROUNDCOVERS**

SYMBOL	NAME	COMMENTS	SIZE	WUCOLS	QTY.
G1	CAREX PRAEGRACILIS CALIFORNIA FIELD SEDGE	PLANT PER DETAIL B 36" O.C.	4" POTS	LOW	19
G2	CEANOTHUS GLORIOSUS 'ANCHOR BAY' ANCHOR BAY CEANOTHUS	PLANT PER DETAIL B 72" O.C.	5 GAL.	LOW	92
G3	ACHILLEA MILLEFOLIUM COMMON YARROW	PLANT PER DETAIL B 24" O.C.	1 GAL.	LOW	43
G4	NOIYO GRAVEL GRAVEL BORDER	2 FOOT WIDE BORDER SURROUNDING THE BUILDING	2"-4"	N/A	423 SQ. FT.

**PLANTING LEGEND NOTES**

1. ALL TREES ARE TO BE STAKED PER DETAIL A
2. ALL SHRUBS ARE TO BE PLANTED PER B
3. CONTRACTOR IS TO PROVIDE AN AUTOMATIC IRRIGATION SYSTEM WITH 100% COVERAGE AND SEPARATE SUN/SHADE AND TURF/GROUNDCOVER SYSTEMS. REFER TO IRRIGATION PLANS FOR SPECIFICS OF INSTALLATIONS.
4. CONTRACTOR SHALL NOT DETOUR FROM ANY OF THE PLANT MATERIAL ON THE LIST UNLESS CONSULTING WITH THE LANDSCAPE ARCHITECT FIRST.
5. CONTRACTOR SHALL INSTALL HEADER AT THE EDGE OF ALL TURF TO SHRUB AREAS. SEE DETAILS FOR MATERIAL.
6. ALL SHRUB AREAS SHALL RECEIVE A 3" LAYER OF MEDIUM SIZED FIR MULCH 1/2" TO 1" IN DIAMETER. TOP SURFACE OF MULCH SHALL BE A MINIMUM OF 1" BELOW ANY ADJACENT HARDSCAPE. "GORILLA HAIR" OR POST CONSTRUCTION WASTE WILL NOT BE ACCEPTED.
7. ALL SLOPE AREAS 3:1 OR GREATER SHALL HAVE JUTE NETTING OR EQUIVALENT SLOPE STABILIZATION MATERIAL APPLIED ON TOP OF ANY APPLIED MULCH.
8. ALL PLANT MATERIAL, COLOR, SIZE AND QUANTITIES ARE TO BE VERIFIED WITH OWNER.
9. PLANT MATERIAL WAS SELECTED PER BIOLOGIST FOR THE TRANSITION RIPARIAN HABITAT.

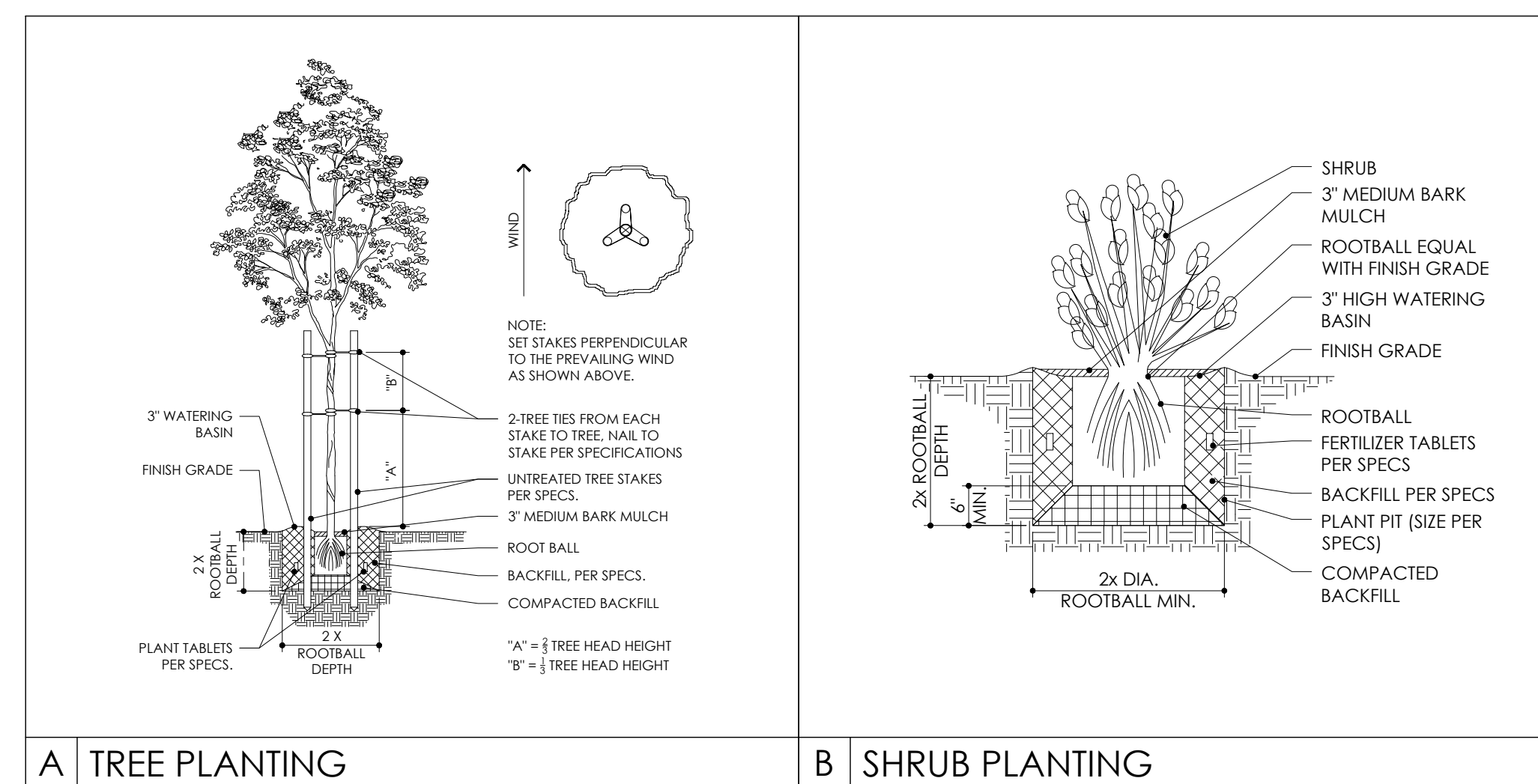

**NOTE:**

GRADING AND SITE DISTURBANCE SHALL REMAIN AT LEAST 6 FEET OUTSIDE OF THE EXISTING OAK'S DRIPLINE WHENEVER FEASIBLE. IF GRADING MUST ENCROACH WITHIN THAT PROTECTED AREA, ALL SUCH WORK SHALL BE CONDUCTED UNDER THE SUPERVISION OF THE LANDSCAPE ARCHITECT/ARBORIST

**VICINITY MAP**

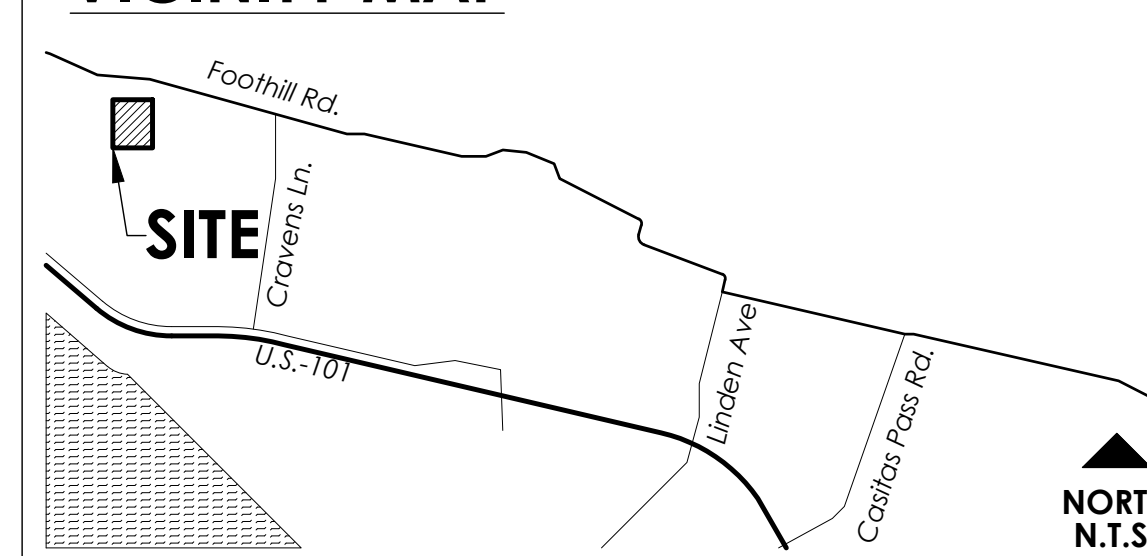

**SHEET TITLE**

**LANDSCAPE  
SCREENING  
PLAN**

**OWNER** Cresco California  
P.O. Box 183  
Carpinteria, California 93014

**DATE** 2021.10.12  
21839

**SHEET NO.**

**L-1.2**



**SLO CULTIVATION**

3889 FOOTHILL ROAD // CARPINTERIA, CALIFORNIA 93013

SHEET TITLE

**PROPOSED RENDERED SITE PLAN**

OWNER Cresco California  
P.O. Box 183  
Carpinteria, California 93014

DATE 2021.10.12  
21839

SHEET NO.

**L-1.4**

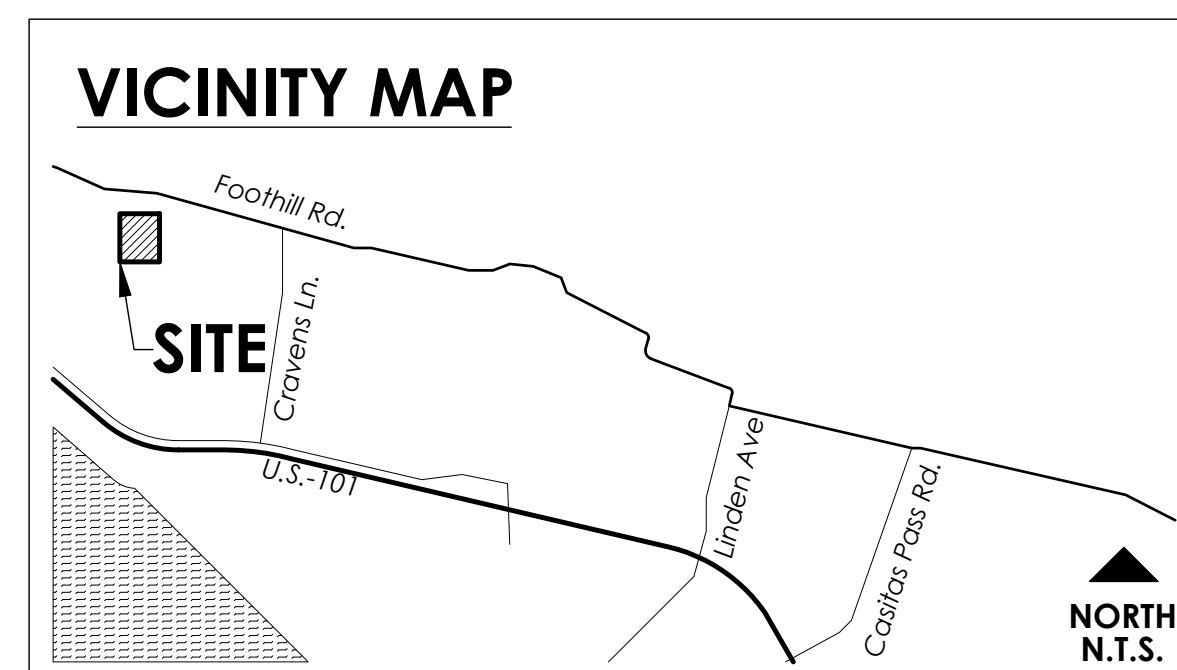

**PROPOSED RENDERED SITE PLAN**

0 25 50 100  
SCALE: 1" = 50'-0" NORTH

NORTH  
N.T.S.

NOT A PART  
REFER TO CAL-TRANS  
LANDSCAPE PLANS

EXISTING BAMBOO SCREENING  
TO REMAIN

EXISTING PINUS SPP.  
TO REMAIN

GREENHOUSE #1

PROPOSED  
PROCESSING

PROPOSED  
GREENHOUSE  
ADDITION

FOOTHILL ROAD

PROPOSED LANDSCAPE SCREENING

EXISTING AVOCADO TREES

EXISTING BARN

EXISTING RESIDENCE

EXISTING GARAGE

EXISTING 20' WIDE PAVED ROAD

ARROYO PAREDON

EXISTING OAK TREE CANOPY

PROPOSED LANDSCAPE

NOT A PART  
REFER TO CAL-TRANS  
LANDSCAPE PLANS

SHEET TITLE

**PROPOSED RENDERED SITE PLAN**

OWNER Cresco California  
P.O. Box 183  
Carpinteria, California 93014

DATE 2021.10.12  
21839

SHEET NO.

**L-1.4**

NORTH  
N.T.S.

0 25 50 100  
SCALE: 1" = 50'-0" NORTH

**PROPOSED RENDERED SITE PLAN**

## **Attachment 6      De-Ionization Details**

# DI Tank Guide & Color Codes



Unit designation	8" Fiberglass	10" Stainless	10" Fiberglass	14" Fiberglass	14" Stainless	Flomax 37	Flomax 45
Volume	0.5 ft <sup>3</sup>	1.6 ft <sup>3</sup>	1.6 ft <sup>3</sup>	3.6 ft <sup>3</sup>	3.6 ft <sup>3</sup>	37 ft <sup>3</sup>	45 ft <sup>3</sup>
Weight	37 lbs	148 lbs	135 lbs	303 lbs	316 lbs	3120 lbs	3790 lbs
Footprint	8"	10"	10"	14"	14"	40"	43"
Height w/ Fittings	23"	42"	45"	50"	50"	96"	96"
Inlet Connection	1" Fem Union	1" Fem Union	1" Fem Union	1" Fem Union	1" Fem Union	2" Fem Camlock	3" Fem Camlock
Outlet Connection	1" Male Union	1" Male Union	1" Male Union	1" Male Union	1" Male Union	2" Male Camlock	3" Male Camlock
Operating Psi (max)	80 psi	80 psi	80 psi	80 psi	80 psi	80 psi	80 psi
Temperature Rating	80° F	180° F	80° F	80° F	180° F	80° F	80° F
Optimum Flow DI (Gpm)*	1 to 2 GPM	2 to 8 GPM	2 to 8 GPM	3 to 20 GPM	3 to 20 GPM	35 to 120 GPM	45 to 200 GPM

\*Lower flows can be achieved with a recirculation system and different flow rates will be suitable for medias other than ion exchange resins



**Red**  
Strong Acid Cation  
(H + Form)



**Black**  
Strong Acid Cation  
(Na + Form)



**Yellow**  
Strong Base Anion  
(OH - Form)



**Green**  
Weak Base Anion  
(OH - Form)



**Brown**  
Mixed Bed



**Blue**  
Mixed Bed Polisher



**Clear**  
GAC Granular  
Activated Carbon

Colored electrical tape is wrapped around the top neck or outlet fitting to designate what type of ion exchange resin is inside the tank.

Color	Resin Type	Commonly referred to as
Red	Strong Acid Cation (SAC) in Hydrogen form	"C" or "Cation" tank
Black	Strong Acid Cation (SAC) in Sodium form	"Sodium C" or "Softening Tank"
Yellow	Strong Base Anion (SBA) in Hydrogen form	"S" or "Strong Base Tank"
Green	Weak Base Anion (WBA) in Hydrogen form	"W" or "Weak Base Tank"
Brown	Mixed Bed Resin (contains both SAC and SBA)	"M" or "Mixed Bed Tank"
Blue	Mixed Bed Resin (contains both SAC and SBA)	"P" or "Polisher Tank"
Clear (No tape)	Granular Activated Carbon (GAC)	"GAC" or "Carbon Tank"



# Flomax DI Tank

**Flomax DI tanks** are an economical and reliable way to achieve high quality 18.2 Meg-ohm demineralized water free of nearly all ionic contaminants that are harmful to many industrial processes. We offer a wide range of sizes and resin types to ensure that you receive the proper quality and quantity of water that you need. Our service team will install, service and replace exhausted DI tanks based on your schedule 24/7.

## Available Media

Cation - Hydrogen Form  
Anion - Strong and Weak Base  
Mixed Bed

## Advantages

- ✓ Fast local service 24/7
- ✓ No capital investment
- ✓ Strict quality control and documentation
- ✓ State of the art regeneration facilities
- ✓ Simple hook up



## Options

Quality instrumentation and controls

Automatic switch over panels

Dedicated ion exchange resins

Recirculating pump skids

37 & 45 cubic foot sizes

Water Linx remote monitoring service



Emergency Service



Units are Certified to your Specifications before Delivery



Fast Local Service



1-800-906-6060  
sales@puretecwater.com  
www.puretecwater.com



# PROPOSAL: 30065-1

3151 Sturgis Road - Oxnard - California - 93031-5387  
 Phone (800) 906-6060 Fax (800) 906-6070  
[www.PuretecWater.com](http://www.PuretecWater.com)

DATE: 07/29/2020

New Account

**CUSTOMER:** Mr. Adam Cavalli  
 (Delivery Information) A-Cavalli Construction  
 Cresco Nursery --- 5,600-GPD  
 Usage  
 3889 Foothill Road  
 Location: Next to Tank Farm  
 Carpinteria, CA 93013  
 805-252-9999  
 amcavalli@gmail.com

**SALES ENGINEER:** Steve Van Wagner  
 Sales Engineer  
 805-340-6488  
 svanwagner@puretecwater.com

## TANK SERVICE PRICING

QTY	DESCRIPTION	EXCHANGE PRICE (ea)	FREQUENCY	MONTHLY RENT (ea)
3	PF41X FLOMAX 45 C - STRONG ACID CATION TANK	\$ 475.00	Will Call	\$ 95.00
3	PF42X FLOMAX 45 W - WEAK BASE ANION TANK	\$ 475.00	Will Call	\$ 95.00
1	Water Linx - Base Subscription	\$ 0.00	28 Day	\$ 125.00

In consideration of the above service and pricing, customer agrees to retain the above service for a 24 Month period. At the end of the initial term, the term will automatically renew for the successive periods of the same duration as the initial term, unless PURETEC or the Customer notifies the other in writing of its intent not to renew the Agreement no sooner than three (3) months before the end of the applicable term.

## EQUIPMENT/LABOR PRICING

QTY	DESCRIPTION	PRICE (ea)	TOTAL
1	OPTIONAL: Custom Build Puretec Quad Aquaswitch, Auto DI Bank Switcher with Installation	\$ 5,600.00	\$ 5,600.00
1	OPTIONAL: Water Linx Real Time Data Monitor SystemModem with Installation ( Customer to Monitor) NOTE The Monthly Service Fee = \$125.00/ monthly	\$ 6,930.00	\$ 6,930.00
<b>TOTAL</b>			<b>\$ 12,530.00</b>

Good Afternoon - Mr. Adam Cavalli

RE: Deionized (DI) Water Exchange Tank Service  
 Zero Waste Water Discharge System



# PROPOSAL: 30065-1

Estimated Daily Usage = Approx. 5,600-GPD

Please find -attached- Puretec Proposal # 30065-1, to supply 3-sets of the larger "Flomax" 45-cu.ft, portable DI water exchange tanks for your nursery application

There will be 2-tanks in each "set" of DI Tanks (1-Cation & 1-Weak Base Anion)

This arrangement will offered the highest volume of water processing and the lowest cost per gallon of DI water produced

----

## 1) ESTIMATED RUN LENGTH PER 2-TANK CATION & WEAK ANION FLOMAX

The estimated run length per set = approx. 19,787-gallons/set

Please refer to -attached- Capacity Calculator Chart

Note a 10% buffer was added to the calculations, due to fluctuations on the feed water quality which can occur on a seasonal basis

----

## 2) WATER QUALITY FROM A 2-TANK - CATION & WEAK ANION SET

a) Estimated Produce Water Total Dissolved Solids (TDS) = Approx. 25-ppm TDS

--

b) Ph = Estimated 6.0-Ph

--

c) NOTE: Weak Anion will not remove silica or CO2

----

## 3) BUDGET MONTHLY OPERATING COST - BASED UPON 5,600-GPD USAGE

### A) NOTES:

19,787-Gallons per DI Set / 5,600-GPD Usage = Approx. 3.5-Days / Flomax Set

Estimated weekly usage = approx. 2-sets of Flomax DI Tanks weekly (4-tanks total)

--

### BUDGET COSTING:

a) Rental = \$95.00/Flomax x 6-tamnks = \$570.00 monthly

--

b) Exchanges = 4-tanks (2-sets) weekly x \$475.00 /tank x 4-weeks/month = \$7,600.00

--

c) Fuel /Delivery Surcharge = \$14.00/delivery x 4-deliveries/month = \$56.00

BUDGET MONTHLY OPERATING COST (A+B+C) = \$8,226.00 MONTHLY

----

## 4) CUSTOMER CRESCO TO PROVIDE:

a) Site Pad Concrete or Asphalt , Approx. 144" Wide x 240" Length

NOTE: Location to allow for safe & easy access for a Route Truck to unload & load at site.

--

b) Forklift - Rated for minimum 5,000+lbs (See Attached Tank Chart)

--

c) All Interconnecting 3" Sch80-PVC Pipe, Valves , Fittings from City Feed Water to DI Exchange Tank Manifold to Pure Water Tank Farm

--

d) ALL Interconnecting Electrical, 120-Volt for Aqua-switch, Water-Linx Monitor, and Level Controls, as needed

--

e) Any Permittng or Validation , if required

--

f) 3" Pressure Regulator (City Feed into Manifold) limited to 70/80-psi



# PROPOSAL: 30065-1

--  
G) Any other itmes required for a complete system  
----

5) PURETEC TO PROVIDE:

- a) 3-Sets of 45-cu.ft Flomax DI Tank (#ea- Cation & 3ea- Weak Anion),  
Dimensions: 42"x42"x96", 3790-lbs each, 3" Cam-lock In/Outlet ( Rental/Exchange Item)  
--
- b) 3-set of 3" Goodyear Jumper hoses w/ 3" S/S Camlocks @ NO Charge  
--
- c) Puretec Service Technician to install jumper hoses anf pressure test at NO Charge  
--
- d) 1ea - 20K Dolan Red/Green Quality Light at NO Charge  
---
- e) OPTIONAL: Puretec custom Quad Bank Aqua-switch, if requested  
--
- f) OPTIONAL: Puretec Water-Linx Real Time Remote Date Monitoring Service (Customer to Monitor)  
----

6) LEAD TIME:

- a) Approx. 10-working Days after receipt of a signed Puretec Proposal and/or Purchase Order  
----

7) TERM LENGTH = 24-months from date of 1st FLomax Delivery

Steve Van Wagner  
 Puretec Industrial Water  
 Cell: 805-340-6488  
 www.puretecwater.com  
 -----  
 .  
 .

Terms are net 30 days, applicable taxes and freight, if appropriate, will be added to the final invoice. Fuel surcharge is currently in effect unless otherwise stated above. Copies/Facsimile signatures will be deemed originals for all purposes.

Pricing valid for 60 days.

Customer acknowledges having read, understood and received a copy of the attached General Terms and Conditions (attached paragraphs 1 through 23) which govern this Agreement and Customer agrees to be bound by all the General Terms and Conditions.

---

Authorized Customer Representative (Print Name and Title)

---

Authorized Customer Representative (Signature)

Date



# PROPOSAL: 30065-1

## BILLING INFORMATION

---

Name	Email	Phone
------	-------	-------

---

Address	City	State	Zip
---------	------	-------	-----

---

**Purchase Order** - Please use the following PO for invoicing. (If applicable, please include a copy of the PO).

Blanket PO       One Time PO

---

Purchase Order Number	Expiration
-----------------------	------------

---

ACH Billing

---

Bank Name

---

Account Number	Routing Number
----------------	----------------

---

Visa / Mastercard / AMEX / Discovery (2% credit card fee applies)

---

Card Number	Expiration	CVC
-------------	------------	-----

---

---

Name on Credit Card	Billing Zip Code
---------------------	------------------

---

For your convenience and security please upload your signed proposal and payment authorization here:

<https://www.dropbox.com/request/sQOUI5qX5EENigVVzEHx>

If tax exempt or resale, please include certificate.





# PROPOSAL: 30065-1

## GENERAL TERMS AND CONDITIONS

1. **APPLICABILITY OF TERMS AND CONDITIONS.** These General Terms and Conditions apply not only to the attached Proposal, but also to any goods or services provided by PURETEC to Customer from the date of Customer's acceptance of the Proposal. These General Terms and Conditions shall apply to any future proposals or orders unless PURETEC and Customer expressly agree to new General Terms and Conditions in writing.
2. **ACCESS.** Customer will provide PURETEC with reasonable and sufficient access to install the water treatment equipment ("the Equipment"). Upon request, Customer will provide PURETEC with reasonable and sufficient access to service the Equipment. Customer represents it has the legal right to provide PURETEC with the access specified above. PURETEC shall have no obligation to obtain any third party approvals, including, but not limited to, landlord consent or governmental permits or licenses, with respect to the installation of or access to the Equipment.
3. **PROVISION OF ELECTRICITY AND WATER BY CUSTOMER.** At its sole cost, Customer will satisfy all electrical and continuous incoming water flow requirements as specified by PURETEC at the location of the Equipment. Customer will, in accordance with all applicable laws and regulations, provide for all disposal of water treatment system effluent from the system at no cost to PURETEC, including, but not limited to, any testing or decontamination of such effluent. Customer will replace any Equipment or ion exchange resins contaminated by exposure to any process or application. Upon request, Customer will provide a completed and signed Resin Process Profile form that specifies the conditions under which all ion exchange resins will be operated.
4. **OWNERSHIP OF LEASED EQUIPMENT.** Customer acknowledges and agrees that any rented/leased Equipment and all inventory, parts and supplies related thereto will remain the sole and exclusive property of PURETEC.
5. **WATER QUALITY AND SUITABILITY FOR CUSTOMER'S APPLICATION.** At its sole cost and expense, Customer will monitor and test water suitability and quality for Customer's application and use. PURETEC will have no responsibility to test or monitor the water for suitability or quality for Customer's use. The failure to monitor the water quality by Customer may damage the Equipment or other property (including Customer's systems) or adversely affect the operation of the Equipment or quality of the treated water. Customer will be solely responsible for any damages to the Equipment or other property caused by Customer's failure to monitor or test water suitability or quality.
6. **POTABLE WATER.** Customer shall use only potable feed water at all times with the Equipment. Customer acknowledges that PURETEC has advised Customer to obtain a water quality light and/or monitor to regularly monitor the water before and after the Equipment for suitability of use.
7. **WATER PRESSURE.** At its sole cost and expense, Customer shall take all steps necessary to insure that at no time will the water pressure to the tanks exceed 80 pounds per square inch or any vacuum nor shall water temperature exceed 100°F. Customer understands that any greater pressure may cause irreparable damage to the tanks, adversely affect the operation of the tanks or adversely affect the quality of the treated water. Customer will be responsible for all damage to their property as a result of any failure to monitor water pressure.
8. **PRICING.** The prices set forth in this Agreement are based upon prices currently charged by PURETEC'S suppliers of services, materials, and parts on the date of this Agreement. If PURETEC is subsequently charged higher prices by such suppliers, PURETEC may increase the prices to Customer during the term by the percentage increase charged by suppliers to PURETEC. Unless otherwise specified in writing, PURETEC's pricing does not include, and PURETEC shall not be responsible for, any taxes, permits, tariffs, duties, fees or shipping costs.
9. **TERM AND RENEWAL.** The initial term of the Agreement is specified in the attached Order between Customer and PURETEC. At the end of the initial term, the term will automatically renew for the successive periods of the same duration as the initial term, unless PURETEC or the Customer notifies the other in writing of its intent not to renew the Agreement no sooner than three (3) months before the end of the applicable term or later than one (1) month prior to the end of the applicable term. Upon any renewal, PURETEC may increase any pricing for services by delivering written notice of such price increase to the Customer.
10. **TERMINATION FOR DEFAULT.** In the event either party commits a material breach of this Agreement and fails to cure such breach within thirty (30) days after receiving written notice thereof, the other party may terminate this Agreement immediately upon written notice to the party in breach.

Initials \_\_\_\_\_



# PROPOSAL: 30065-1

11. **REMEDIES FOR DEFAULT.** Customer acknowledges that the Equipment is specially delivered and installed by PURETEC at the property of Customer. Customer further acknowledges that the pricing under this Agreement was provided with the understanding that the Customer will complete the initial term and any renewal term. The parties further acknowledge that the amount of loss or damages likely to be incurred by PURETEC in the event of breach by the Customer is incapable or difficult to ascertain. If Customer breaches the Agreement by terminating the Agreement before the end of the initial term or renewal term or PURETEC terminates this Agreement pursuant to paragraph 10 above, Customer agrees to pay as damages and not as a penalty the resulting product of eighty percent (80%) multiplied by all monthly rental charges remaining under the term of the Agreement. PURETEC and Customer agree that this amount bears a reasonable relationship to the probable loss likely to be incurred by PURETEC in the event of early termination of the Agreement or default by Customer. The amount of these damages will become immediately due and payable on termination of the Agreement. Such agreed upon damages will apply only to damages sustained as a result of early termination of the Agreement or termination by default and PURETEC reserves all other rights for any further or other breach of the Agreement.

12. **PAYMENT.** Customer will be billed monthly by PURETEC for all services. Payments are due within thirty (30) days of billing. Customer agrees to pay interest on past due balances of one and one-half percent (1-1/2%) per month.

13. **DISCLAIMER OF WARRANTIES.** EXCEPT AS EXPRESSLY SET FORTH IN THIS AGREEMENT, PURETEC MAKES NO WARRANTIES OF ANY KIND WHATSOEVER, EXPRESS OR IMPLIED, REGARDING THE EQUIPMENT OR SERVICES PROVIDED BY PURETEC, INCLUDING, BUT NOT LIMITED TO, THE QUALITY, QUANTITY, OR USE AND APPLICABILITY OF WATER. PURETEC HEREBY EXPRESSLY DISCLAIMS ANY AND ALL IMPLIED WARRANTIES OF MERCHANTABILITY OR FITNESS OR SUITABILITY FOR A PARTICULAR USE OR PURPOSE. CUSTOMER AFFIRMS THAT CUSTOMER HAS NOT RELIED ON PURETEC'S SKILL OR JUDGMENT TO SELECT THE TYPE OF EQUIPMENT, PURIFIED WATER OR WATER QUALITY FOR ANY PARTICULAR PURPOSE BY CUSTOMER.

14. **LIMITATION OF LIABILITY.** In recognition of the relative risks and benefits and to provide Customer with the most advantageous pricing, PURETEC and Customer agree to limit PURETEC'S liability under this Agreement as follows: TO THE FULLEST EXTENT ALLOWED BY LAW, CUSTOMER'S USE OF THE EQUIPMENT OR TREATED WATER IS AT CUSTOMER'S SOLE RISK. PURETEC, ITS SHAREHOLDERS, OFFICERS, OR EMPLOYEES, SHALL NOT BE LIABLE TO CUSTOMER FOR ANY INDIRECT, SPECIAL, INCIDENTAL, OR CONSEQUENTIAL DAMAGES OF ANY CHARACTER, INCLUDING, WITHOUT LIMITATION, LOST PROFITS, PERSONAL INJURY (INCLUDING DEATH), PROPERTY DAMAGE, DAMAGES FOR LOSS OF GOODWILL, LOSS OF USE, WORK STOPPAGE, OR ANY AND ALL OTHER COMMERCIAL DAMAGES OR LOSSES. THE FOREGOING SHALL APPLY EVEN IF PURETEC HAS BEEN ADVISED OF THE POSSIBILITY OF SUCH DAMAGES AND NOTWITHSTANDING THE FAILURE OF THE ESSENTIAL PURPOSE OF ANY LIMITED REMEDY. PURETEC'S LIABILITY UNDER THIS AGREEMENT IS LIMITED TO THE AMOUNT PURETEC RECEIVED FROM CUSTOMER PURSUANT TO THE ORDER DURING THE APPLICABLE TERM.

15. **INDEMNIFICATION.** Customer agrees to indemnify, defend and hold PURETEC or its agents and employees harmless from any claims made by third parties against PURETEC or its agents or employees arising out of CUSTOMER'S use of the Equipment, breach of Customer's obligations under these Terms and Conditions, leakage, or use of water, including, but not limited to, any claims for property damages, personal injury, or economic loss. Notwithstanding the above, Customer shall have no obligation to indemnify, defend or hold PURETEC or its agents and employees harmless for any claims made by third parties arising out of PURETEC's sole negligence.

16. **AMENDMENTS.** These Terms and Conditions may only be amended by written agreement executed by both PURETEC and Customer.

17. **APPLICABLE LAW.** This Agreement is made with reference to and shall be governed by and construed in accordance with the laws of the State of California, without regard to the conflict of laws rules of the State of California or any other jurisdiction that would call for the application of the laws of any jurisdiction other than the State of California.

18. **ARBITRATION.** Except as set forth below in paragraph 19, any dispute, claim, or controversy between the parties relating to or arising out of the interpretation or performance of this Agreement shall be resolved by binding arbitration conducted by a single arbitrator selected by the parties or, if the parties cannot agree on an arbitrator, appointed by the Superior Court for the County of Ventura, State of California pursuant to California Code of Civil Procedure § 1281.6. The location of the arbitration hearing shall be Ventura County, California. The award of the arbitrator shall be final and judgment entered in the Superior Court for the County of Ventura, State of California. Any application for provisional remedies filed under California Code of Civil Procedure § 1281.8 or petition to compel arbitration shall be filed in the Superior Court for the County of Ventura, State of California. The hearing shall be governed by the California Code of Civil Procedure § 1281 et seq., including California Code of Civil Procedure § 1283.05.

Initials \_\_\_\_\_



# PROPOSAL: 30065-1

19. **EXCEPTIONS TO ARBITRATION.** Notwithstanding anything to the contrary in paragraph 17, the parties have no obligation to arbitrate the following disputes, claims, or controversies: (1) claims for damages of less than \$25,000; (2) claims for specific performance; and (3) claims for unpaid invoices. The parties agree that the exclusive forum for the resolution of such claims shall be the Superior Court for the County of Ventura, State of California.

20. **ATTORNEY'S FEES.** The prevailing party in any legal action arising out of this Agreement, whether in arbitration or otherwise, shall be entitled to recover its reasonable attorneys' fees, costs, and expenses (including expert witness fees) from the other party.

21. **COMPLETE AGREEMENT.** This Agreement supersedes any and all other agreements, whether oral or in writing, between the parties and contains all of the covenants and agreements between the parties. Except as expressly set forth herein, no representations, inducements, promises, or agreements, oral or otherwise, have been made by any party or anyone acting on behalf of any party. If any provision of this Agreement is determined by any court of competent jurisdiction or duly authorized arbitrator(s) to be invalid, illegal, or unenforceable to any extent, that provision shall, if possible, be construed as though more narrowly drawn, if a narrower construction would avoid that invalidity, illegality, or unenforceability or, if that is not possible, that provision shall, to the extent of that invalidity, illegality, or unenforceability, be severed, and the remaining provisions of this Agreement shall remain in effect.

22. **DISCLOSURE OF RISKS FROM LEAKAGE; WAIVER AND RELEASE OF CLAIMS FOR WATER LEAKS.** Customer acknowledges that is has been advised by PURETEC that there is a high risk of leaks from purified water systems. Such systems should be installed only where there is adequate drainage and in a manner to avoid damage from leaks. Customer hereby acknowledges and affirms that Customer has independently evaluated and designated the location for the installation of the purified water system, products and Equipment. Customer further acknowledges and agrees that PURETEC shall not be liable to Customer for any claims, demands, actions, causes of action, obligations, losses, liabilities, damages, costs or expenses of any nature or type whatsoever ("Claims"), directly, indirectly, or in any manner whatsoever, caused by or related to water leaks, including, without limitation, property damage, business interruption, mold, or personal injuries, and Customer hereby expressly waives, releases and forever discharges PURETEC of and from any and all such Claims. Customer hereby covenants and agrees never to commence or prosecute any action or proceeding against PURETEC based upon the Claims covered by the foregoing release. Customer will monitor and inspect the purified water system product and Equipment for any leaks. This provision shall apply to any leaks or spillage of water by PURETEC during any servicing, installation or removal process.

23. **FORCE MAJEURE.** If the performance of this Agreement or any obligation hereunder is prevented or restricted by reason of fire, work stoppage, war, governmental action, natural disaster, or other causes beyond the reasonable control of PURETEC, PURETEC, upon giving written notice to Customer, shall be excused from performance to the extent of such prevention or restriction.

Effective May 23, 2020

Initials \_\_\_\_\_

## Important Notice

**Water leaks are highly likely with any water treatment system. Below are some precautions to prevent water leaks and/or resin spillage.**

1. Municipal water pressure often increases significantly at night when there is little water usage. This can put excessive strain on DI tanks and connecting hoses. The DI systems are not intended for water pressure to exceed 80 psi. If possible, shutting off the water supply to DI tanks at night is a good safeguard to prevent water leaks.
2. It is also highly recommended that a pressure regulator (set below 80psi) is installed prior to the DI tank system. Pressure regulators are prone to failure and need to be maintained on a frequent basis.
3. It is a good idea to have a floor drain and wall protectors installed in the same room as the DI tanks.
4. If the tanks will be exposed to freezing conditions or feed water above 120 F then this can likely lead to water leaks.
5. If any vacuum occurs in the DI system, then the DI tanks will likely rupture and leak. A vacuum breaker should be installed prior to the DI tanks to be safe. Some examples of when a vacuum may occur are when DI tanks are elevated from their point of use, a fire hydrant was exercised on the street or the DI water is re-pressurized after the DI tanks.
6. When a softener is used before a water heater, the pop off relief valve should be in working order on the water heater.
7. If the DI water is going to a storage tank, the float level switches need frequent maintenance to prevent overfilling.
8. There should always be a post-filter placed after DI tanks in the event of a lateral failure inside the tank which will cause resin to leak into the water supply. A post filter (5-micron pore size) will capture any loose resin beads and prevent any further contamination.
9. If possible, placing the DI tanks outside is another safeguard to prevent water damage from leaks.
10. Water backflow into the inlet of the DI tank will cause resin leakage from the inlet of the tank.

**A note on leak detectors:** Leak detectors are not reliable, and you should not rely on them as a foolproof method to prevent water related damages. Furthermore, if the leak occurs after the DI tanks, then the deionized water often doesn't activate the leak detector since deionized water is not very conductive.

**NOT A WARRANTY:** This notice is provided for informational purposes only and does not constitute a warranty or guaranty of any kind by PURETEC. The only warranties provided by PURETEC are as expressly set forth in the General Terms and Conditions. Except as otherwise expressly agreed by PURETEC in writing, Customer shall be solely responsible and liable for the performance of all appropriate maintenance and operation of the water treatment system.

Initials \_\_\_\_\_