

Project: AT&T at Vandenberg Hills
Little League
APN: 097-371-051 (Portion)
Folio: 003918
Agent: JJS

LEASE AGREEMENT
AT&T WIRELESS at Vandenberg Hills Little League

THIS LEASE AGREEMENT is made by and between the

COUNTY OF SANTA BARBARA,
a political subdivision of the State of California,
hereinafter referred to as "COUNTY,"

and

New Cingular Wireless PCS, LLC,
a Delaware limited liability company,
dba AT&T Wireless,
hereinafter referred to as "LESSEE,"

with reference to the following:

WHEREAS, COUNTY is the owner of that certain real property located in the County of Santa Barbara commonly known as Vandenberg Hills Little League Field (hereinafter "County Property"), which property is located at 300 Albireo Avenue in Lompoc, California, and is more particularly described as Assessor's Parcel Number 097-371-051 which property is used for the purposes of a county park and little league fields (hereinafter "Property") and is shown as the diagonally slashed area of Exhibit "A", attached hereto and incorporated herein by reference; and

WHEREAS, LESSEE desires to enter into a lease agreement (hereinafter "Agreement"), with the COUNTY to occupy and use a portion of said Property for a wireless communication facility subject to the terms and conditions contained herein.

NOW, THEREFORE, in consideration of the provisions, covenants, and conditions, contained herein, the parties agree as follows:

1. **ADMINISTRATION AND ENFORCEMENT:** The provisions of this Agreement shall be administered and enforced for the COUNTY by the COUNTY'S General Services Department.

003918

2. **LEASED AREA:** COUNTY hereby leases to LESSEE and LESSEE hereby takes from COUNTY the specific portion of the Property (hereinafter "Site") as shown on Exhibit "B", attached hereto and incorporated herein by reference, for the construction and operation of LESSEE'S wireless communication facility together with the new pole-mounted antennas to be installed.

3. **ACCESS TO THE SITE:** LESSEE shall be allowed to access the Site through the Property during normal operating hours. LESSEE shall only access the Site on the access road marked on the architectural plans attached hereto as Exhibit "C" and by reference made a part hereof. For any required access after the County Park's normal operating hours (emergency situations and equipment failure excepted), LESSEE shall give reasonable notice, which shall be defined as five (5) business days, to the COUNTY'S Real Property Manager prior to gaining access to the Site; provided, however, in the event of an emergency or equipment failure, LESSEE may access the Site and shall endeavor to notify the COUNTY'S Real Property Manager at (805) 568-3070 prior to accessing the Site and in the event LESSEE is unable to reach the COUNTY'S Real Property Manager, LESSEE shall notify COUNTY of such access within twenty-four (24) hours after said access. COUNTY shall not be responsible for maintaining the access road to the Site.

COUNTY shall not be liable to LESSEE for lack of access to the Site as a result of natural causes. However, in the event that the Site becomes inaccessible as a result of natural causes, COUNTY shall to the extent necessary cooperate with LESSEE to restore access in a timely fashion.

In the event COUNTY implements security programs and policies as part of County's governing ordinance, LESSEE shall comply with such reasonable security programs and policies.

4. **PURPOSE AND USE:** LESSEE shall use the Site to construct, maintain, repair, alter, replace, upgrade and/or remove or have constructed, maintained, repaired, altered, replaced, upgraded all or any portion of LESSEE'S wireless communication facility, including but not limited to, the equipment shelter, radio equipment, antenna support structures, antennas, utility conduits, poles, wires, anchors, guys, and all other appurtenant equipment and operations which are incidental thereto and necessary to operate and maintain LESSEE'S wireless communication facility (hereinafter "Facility"), and to transmit and receive communication signals in any and all frequencies which do not interfere with other wireless communications existing as of the date of this Agreement, and for all purposes incidental thereto. LESSEE shall ensure that both the use and construction of the Site is in accordance with the Conditions of Approval (or any subsequent changes or modifications thereof) set out in Attachment B of the COUNTY'S Planning Commission Conditions of Approval dated July 29, 2020, Case No. 19CUP-00000-00022. LESSEE shall be responsible for supplying, installing and maintaining all power and utilities for the Site.

LESSEE'S use of the Site shall conform to the equipment and antenna specifications described in Exhibit "D", attached hereto and by reference made a part hereof. LESSEE shall comply with any land use and building permit requirements of the Santa Barbara County Planning Department. LESSEE shall not expand its use of the Site beyond the scope of said specifications nor use the Site for any other purposes without the express written approval of the COUNTY'S Real Property Manager, such approval not to be unreasonably withheld, conditioned or delayed, and

003918

comply with all requirements of any and all permits. Approval from COUNTY's Real Property Manager neither excuses LESSEE from securing any permits or other approvals required to implement changes LESSEE proposes to the Site or its Facility nor obligates other COUNTY departments to issue permits for or approve any changes LESSEE proposes to the Site or its Facility. LESSEE shall comply with all requirements of any and all permits. It is understood and agreed to by each party that LESSEE shall have the right to make changes to and replacements of equipment which are of a substantially similar or "like-kind" nature without having to obtain the approval of COUNTY, provided such changes do not alter the square footage of the lease area of the Site nor change the visual impact, antenna size, or change the level of antenna transmission of LESSEE'S Site and Facility. LESSEE shall notify COUNTY in writing within thirty (30) days of any such changes made to LESSEE'S Facility without COUNTY'S consent.

5. **TERM:** The initial term of this Agreement is for a period of five (5) years ("Initial Term"), commencing on May 1, 2021 (hereinafter "Commencement Date") and shall terminate on April 30, 2026, unless sooner terminated as hereinafter provided.

6. **EXTENSION AND RENEWAL OF LEASE:** In the event this Agreement has not otherwise been terminated and LESSEE is not in Default (after expiration of all cure periods) at the end of the above-referenced term, then such term may be extended for three (3) additional terms of five (5) years each (each a "Renewal Term") upon mutual agreement by LESSEE and COUNTY. All extensions shall be requested by LESSEE in writing at least three (3) months, but no more than twelve (12) months, prior to the expiration of the Initial Term or then current Renewal Term, and such extensions shall be set forth as follows:

Extension Period One:	May 1, 2026 through April 30, 2031
Extension Period Two:	May 1, 2031 through April 30, 2036
Extension Period Three:	May 1, 2036 through April 30, 2041

In the event of any such extensions the Rent shall be calculated as per Section 8, RENT, and Section 9, COST OF LIVING ADJUSTMENT, or such other basis as the parties may then agree. The Initial Term and any Renewal Terms are collectively referred to as the Term ("Term").

7. **SECURITY DEPOSIT:** A deposit in the amount of FIVE THOUSAND DOLLARS (\$5,000.00) shall be due to COUNTY within forty-five (45) days after the date this Agreement is signed by COUNTY (hereinafter "Security Deposit"). COUNTY shall have the right to use monies from this Security Deposit to make any repairs or equipment removal not made by LESSEE for which LESSEE is otherwise obligated to make and to restore the Site in the event LESSEE does not properly do so according to its obligations as set forth in Section 13, ABANDONMENT OF SITE/DISPOSITION OF PERSONAL PROPERTY, Section 17, MAINTENANCE AND REPAIR, or Section 35, SURRENDER OF PREMISES, herein. In the event that, during the course of this Agreement, COUNTY is required to use a portion of the Security Deposit to make repairs, then LESSEE shall, within thirty (30) days of such repair and LESSEE'S receipt of COUNTY'S written notice to reimburse COUNTY, thereafter reimburse the Security Deposit monies used by COUNTY in connection with the repairs. At the expiration or earlier termination of this Agreement, COUNTY shall release the Security Deposit, less any costs related to repair or equipment removal, if any, within thirty (30) days of receipt of LESSEE'S

003918

written notice in accordance with the terms of Section 35, SURRENDER OF PREMISES, herein.

8. **RENT:** The base annual rent payable by LESSEE to COUNTY during the first year of this Agreement shall be THIRTY THOUSAND and 00/100 DOLLARS (\$30,000.00) ("Rent") in lawful money of the United States of America due concurrent and in accordance with Section 7, SECURITY DEPOSIT, of this Agreement. The initial Rent payment is due no later than forty-five (45) days after the Commencement Date.

Thereafter, Rent shall be paid annually, in advance, on or before May 1st of each and every calendar year of the Term beginning in the year 2022. Rent due for any period during the Term which is for less than one (1) calendar year shall be prorated based upon a three hundred sixty-five (365) day year. The Rent shall be subject to adjustment as set out in Section 9, COST OF LIVING ADJUSTMENT, below. If Rent is not paid ten (10) days after the date due (the Commencement Date or any anniversary thereof), LESSEE shall pay the interest accrued on the unpaid balance at ten percent (10%) per annum from the date it became due until it is paid.

Rent payments shall be made payable to "County of Santa Barbara" and sent to COUNTY at the address as stated in Section 26, NOTICES, herein below.

9. **COST OF LIVING ADJUSTMENT:** Beginning on May 1, 2022, and on each and every anniversary of this date, the Rent provided in Section 8, RENT, above shall be subject to a Cost of Living Adjustment and shall be increased from the Rent payable during the immediately preceding year of the Term by three percent (3%).

10. **SITE SUITABILITY:** LESSEE has investigated the Property and the Site and has determined that they are suitable for LESSEE'S intended operations, and therefore, LESSEE hereby accepts, by way of executing this Agreement, the Site in its existing condition.

LESSEE ACKNOWLEDGES THAT, EXCEPT AS STATED HEREIN, INCLUDING BUT NOT LIMITED TO LESSEE'S UTILITY INSTALLATION REFERENCED IN SECTION 15 HEREOF, COUNTY HAS MADE NO REPRESENTATIONS OR WARRANTIES ABOUT THE CONDITION OF THE PROPERTY OR SITE, OR THE SUITABILITY OF SAME FOR THE INTENDED USE BY LESSEE.

11. **CONSTRUCTION OF THE FACILITY AND FUTURE ALTERATIONS:** Prior to the commencement of LESSEE'S construction of its Facility, a pre-construction meeting will be scheduled with COUNTY, through the Real Property Manager, or their designated agent, at the Site to review project procedures, designation of project and/or construction managers, and project scheduling. LESSEE shall submit to the Real Property Manager, or their designated agent, periodic status reports indicating description of finished work and milestones.

Upon compliance with all required permitting, construction of the Facility, at LESSEE's sole expense, shall begin promptly after the Commencement Date and shall be pursued expeditiously to completion. Copies of all required land use permit(s) and building permit(s), as applicable, are attached hereto and by reference made a part hereof as Exhibits "E" and "F", respectively.

LESSEE shall install and construct the Facility in accordance with Exhibits "C", "E" and "F", and LESSEE acknowledges that compliance of the construction of its Facility may be

003918

administered by COUNTY's Planning and Development Department and/or Building and Safety Division. LESSEE shall give COUNTY no less than ten (10) days written notice prior to the commencement of any installation or construction work in, on, or about the Site, with the exception of regular maintenance, minor repair visits and emergency work, and shall keep the Property and Site free and clear of liens for labor and materials by or on behalf of LESSEE.

Any work done by LESSEE or its agents on or around the Site during the construction of LESSEE's Facility shall conform to the construction schedule described in Exhibit "G", attached hereto and by reference made a part hereof. LESSEE or its Contractor shall, during all phases of construction, have a designated representative present on the Site to monitor construction and ensure compliance with the aforementioned work plan. In addition, COUNTY may, at its option, have a designated representative on Site who, during all phases of construction, shall have the right to suspend and/or terminate any and all phases of such construction that do not substantially comply with Exhibit "C," "D," "E," or "F". The construction and installation to be done hereunder shall be scheduled and executed at such time and in such a way as to cause, to the extent reasonably feasible, the least inconvenience to the COUNTY, its officers, agents, and employees and with proper consideration for the rights of the public and other COUNTY tenants, vendors, and contractors.

Upon completion of the installation and construction of the Facility, a post-construction meeting for final inspection will be scheduled with COUNTY, through the Real Property Manager, or its designated agent, at the Site for final inspection of completed work.

In the event that LESSEE wishes during the installation and construction or in the future to alter or improve the Site in additional ways not anticipated by this section or by Section 14.D herein, LESSEE shall obtain the advance written approval from the COUNTY'S Real Property Manager, which approval shall not be unreasonably withheld, conditioned or delayed, and comply with all requirements of any permits. COUNTY, in its role as proprietor of the Property, shall use its best efforts to respond in a timely manner to LESSEE'S request to alter or improve the Site.

The requirements relating to construction set forth herein are those of COUNTY as landowner and not as a governmental entity. Nothing in this Agreement shall be construed to entitle LESSEE to undertake construction of the Facility or additional future improvements without complying with all permitting required by COUNTY in its governmental capacity.

COUNTY warrants that it has the right and the ability to enter into this Agreement on the subject Property.

12. **TITLE TO FACILITY:** Title to the Facility shall vest with LESSEE. Upon expiration of the Term of this Agreement, or earlier termination as provided herein, at LESSEE'S option, and upon COUNTY'S approval, title to the Facility and utility conduits, except as stated below, shall pass to COUNTY and the parties shall execute whatever documents are reasonably necessary to evidence such passing of title. In the event COUNTY takes title to the Facility, COUNTY acknowledges and agrees to take possession of the Facility and utility conduits in their then "as-is" condition, without any representation or warranty by LESSEE as to their fitness for a particular purpose, and LESSEE shall thereafter have no further liability for same. For purposes of this Section 12, **TITLE TO FACILITY**, radios, radio cabinet equipment, antennas, and other similar electronic equipment and any antenna structures (hereinafter "LESSEE'S Owned Facilities") shall not be a part of the Facility, and LESSEE shall retain title to such.

13. **ABANDONMENT OF SITE/DISPOSITION OF PERSONAL PROPERTY:**

LESSEE shall not abandon, vacate, or surrender the Site at any time during the Term of this Agreement and if LESSEE does abandon, vacate, or surrender said Site, any personal property belonging to LESSEE and left on the Site more than sixty (60) days after notice from COUNTY to LESSEE of such abandonment, vacation or surrender shall be deemed abandoned at the option of the COUNTY, and title to such shall pass to COUNTY. This provision shall also apply to personal property left after the termination or other expiration of this Agreement and any applicable removal periods as described in Section 35, SURRENDER OF PREMISES. Notwithstanding the foregoing, COUNTY acknowledges that the Facility will be operated as an unmanned facility.

14. **NONINTERFERENCE:**

A. Property. LESSEE agrees not to use, nor permit those under its control, including, but not limited to, its employees, tenants, LESSEE'S invitees, agents and/or contractors, to use any portion of the Property, Site, or the Facility in any way which unreasonably interferes with the non-telecommunications use of the Property by COUNTY. Such interference shall be deemed a material breach, and in the event of such interference caused by LESSEE, LESSEE shall terminate said interference promptly upon receipt of written notice from COUNTY. In the event LESSEE fails to stop such interference within forty-eight (48) hours after receipt of such notice, LESSEE shall cease operation of the Facility or remove the interfering equipment until such interference is eliminated.

B. Telecommunications. LESSEE shall meet and comply with all non-interference rules of the Federal Communications Commission (hereinafter "FCC"). Subject to LESSEE'S rights hereunder, LESSEE shall not use, nor shall LESSEE permit its employees, invitees, agents or any others under its control to use the Property or Site in any way which materially interferes with the operations of other telecommunications users on the Property as of the date of execution of this Agreement, nor shall LESSEE at any time after the Commencement Date of this Agreement change the operations of its Facility or alter its Facility in such a manner which causes material interference to COUNTY or any other then-existing users or tenants on the Property as of the date of the change or alteration to the Facility. Such interference shall be deemed a material breach, and in the event of such interference caused by LESSEE, LESSEE shall terminate said interference promptly upon notice from COUNTY. In the event LESSEE fails to stop such interference within forty-eight (48) hours after receipt of such notice, LESSEE shall cease operation of the Facility or remove the interfering equipment until such interference is eliminated. COUNTY agrees that any other tenants of the Property who currently have or in the future take possession of the Property will not be permitted to install new or additional equipment that causes interference to the operation of LESSEE'S Facility as of the date of such installation, provided LESSEE is in compliance with this Section.

C. Emergency. In the event of an emergency which threatens bodily harm and involves COUNTY in its governmental capacity and the powering down of LESSEE'S Facility is required to respond to such emergency, COUNTY may require LESSEE to power down its operations at the Site without LESSEE'S consent. COUNTY shall use its best efforts to notify LESSEE as soon as possible of said emergency and COUNTY'S intent to require LESSEE to temporarily terminate its

003918

operations. COUNTY shall cooperate with LESSEE in the restoration of use when COUNTY has determined, in COUNTY'S sole and reasonable discretion that the emergency has ended.

D. Equipment Modification. LESSEE shall obtain the written consent of COUNTY, which shall not be unreasonably withheld, conditioned, or delayed, prior to any proposed change in LESSEE'S use of the Site beyond the scope of said specifications in Exhibit "D"; including but not limited to antenna transmission, location or size of the Facility. Notwithstanding the preceding sentence, LESSEE, upon notice to COUNTY, may modify or upgrade its equipment and antennas, so long as such alterations do not increase their level of transmission, or change exterior location or size, or otherwise exceed the limits set forth in Section 4, PURPOSE AND USE, or in Exhibit "D" of this Agreement; without the written consent of COUNTY, which shall not be unreasonably withheld, conditioned, or delayed. LESSEE may remove its radio equipment, antennas, cabling, back up batteries and related equipment at any time.

E. Relocation. COUNTY reserves the one-time right, at any time after the expiration of the Initial Term, to reasonably designate a new location for LESSEE'S Facility and to move said Facility elsewhere on the Property, provided that COUNTY shall give LESSEE at least One Hundred Twenty (120) days written notice of its request to relocate LESSEE'S Facility. The relocation of LESSEE'S Facility shall be done in accordance with the following terms:

- (i) The work and labor to relocate LESSEE'S Facility shall be done exclusively by LESSEE or its designated agents, and shall be done at LESSEE's sole cost and expense. The relocation of LESSEE'S Facility shall not result in any interruption of the communications service provided by LESSEE from the Property. The relocation of LESSEE'S Facility shall not impair, or in any manner alter, the quality of communications service provided by LESSEE from the Property. The relocation shall include new access and utility routes as reasonably required by LESSEE'S use of the new location of LESSEE'S Facility. The relocation of LESSEE'S Facility shall be done in accordance with the terms and conditions contained in paragraphs (ii), (iii) and (iv) below.
- (ii) COUNTY will exercise its right to relocate LESSEE'S Facility by delivering written notice to LESSEE. In the notice, COUNTY will propose an alternate site on the Property to which LESSEE may relocate its Facility. LESSEE will have sixty (60) days from the date it receives the notice to evaluate the alternate site. If LESSEE fails to approve or disapprove of the alternate site within the 60-day period or fails to request an extension of the review period in writing, then LESSEE will be deemed to have approved such proposed relocation. If LESSEE disapproves of the alternate site, then COUNTY, if practicable, may thereafter propose a new alternate site or a choice of alternate sites by notice to LESSEE in the same manner described above. LESSEE will then have the option to choose one of the new alternate sites within sixty (60) days from the date LESSEE receives notice of the new alternate site, or if none of the alternate sites enable LESSEE to continue its operations in a

003918

manner consistent with its operations at the original location of the Site, LESSEE may terminate this Agreement by providing COUNTY with ninety (90) day's written notice. Notwithstanding anything to the contrary contained herein, COUNTY shall use its best efforts to provide an alternate site for its proposed relocation. Any relocation site which COUNTY and LESSEE agree upon in writing is hereinafter referred to as the "Relocation Site". Within thirty (30) days after LESSEE has accepted the Relocation Site, LESSEE shall submit its application for any applicable permits for the Relocation Site and pursue permits expediently until obtained. LESSEE will have a period of ninety (90) days after obtaining its permits for the Relocation Site to relocate LESSEE'S Facility to the Relocation Site and cease operations at the previous Site.

- (iii) During the relocation of LESSEE'S Facility to the Relocation Site, LESSEE shall be allowed to install a temporary facility on COUNTY'S Property in a location approved by COUNTY, which approval shall not be unreasonably withheld, conditioned or delayed. Upon completion of the Relocation Site, LESSEE shall promptly remove its temporary facility.
- (iv) Upon relocation of LESSEE'S Facility, or any part thereof, to the Relocation Site, this Agreement shall be amended to show the new location. Each party hereby agrees that the Relocation Site (including the access and utility right of way) may be surveyed by a licensed surveyor at the sole cost of LESSEE and such survey shall be included in the lease amendment and become a part thereof and control in describing the Site. Except as expressly provided in this subsection, both parties hereby agree that in no event will the relocation of LESSEE'S Facility under the provisions of Section 14.E, or any part thereof, affect, alter, modify or otherwise change any of the terms and conditions of this Agreement.

15. **UTILITY CHARGES:** LESSEE, upon obtaining the required permits and approvals, shall have the right to install and maintain the necessary mains and ancillary equipment required to bring utility service to the Site and Facility, as described and depicted in Exhibit "C", at its sole cost and expense. All accounts for such utilities shall name LESSEE as the responsible party.

LESSEE shall be responsible for supplying and maintaining all power and utilities necessary for LESSEE's operations at the Site and Facility. LESSEE shall pay when due all charges for utilities used by LESSEE.

16. **TAXES AND ASSESSMENTS:** This Agreement may confer a possessory interest on LESSEE and LESSEE shall pay and discharge any and all property taxes and/or assessments, including special assessments and possessory interest taxes, if any, which, due to LESSEE'S Facility may be levied upon said Property, Facility and/or Site during the Term of this Agreement.

003918

17. **MAINTENANCE AND REPAIR/GRAFFITI REMOVAL:** LESSEE agrees at its sole expense to keep in good maintenance and repair, reasonable wear and tear excepted, the Site and Facility. If LESSEE delays in making any repairs so that it becomes necessary for COUNTY, for sake of the operation of the Property, to make such repairs, then COUNTY shall, after providing the notice required, have the right to do so and use monies from the Security Deposit to pay the cost of such repairs. COUNTY shall not have any responsibility to maintain the Site or Facility, except to the extent such maintenance is required due to COUNTY'S negligence or intentional acts or omissions.

LESSEE shall, within twenty (20) days after receipt of notice from COUNTY, commence to perform maintenance and repair and remove or have removed graffiti from the Facility and Site at its sole expense.

18. **ASSIGNMENT/SUBLEASE/HYPOTHECATION:** LESSEE shall not assign, license, or sublease the Site or any part thereof or any right or privilege appurtenant thereto without COUNTY'S written consent which consent shall not be unreasonably withheld, conditioned or delayed. Notwithstanding the above, upon written notification to COUNTY, LESSEE may assign this Agreement to its parents, partners, or affiliates, or to an entity that purchases all or substantially all of LESSEE'S assets in the FCC market in which the Property is located ("Transferee").

LESSEE shall not mortgage, pledge, hypothecate, or encumber the Property, the Site, or any interest therein, including without limitation its leasehold; nor shall LESSEE mortgage, pledge, hypothecate, or encumber any improvements placed upon the Property or Site whether such improvement is placed thereon before or after the date of execution of this Agreement.

Any attempt to assign, license, sublease, mortgage, pledge, hypothecate or in any other way encumber LESSEE'S rights under this Agreement or LESSEE'S interest in the Site without COUNTY'S consent shall be void and without legal effect.

Upon COUNTY's receipt of written notice of LESSEE's assignment in full to a Transferee of this Agreement or upon COUNTY's consent to any other assignment, LESSEE will be relieved of all future performance, liabilities and obligations under this Agreement to the extent of such assignment.

19. **SUCCESSORS IN INTEREST:** This Agreement and the covenants contained herein shall be binding upon and inure to the benefit of the respective parties, their heirs, personal representatives, successors and assigns and to any organization into which LESSEE may be merged.

20. **INDEMNIFICATION:** LESSEE shall defend, indemnify, and save harmless COUNTY, its officers, agents, and employees, from any and all claims, demands, damages, costs, expenses (including reasonable attorney's fees), judgments, or liabilities arising out of LESSEE's breach of this Agreement or occasioned by any act or omission to act on the part of LESSEE or its agents or employees or other independent contractors directly responsible to LESSEE; except those claims, demands, damages, costs, expenses (including reasonable attorney's fees), judgments or liabilities resulting from the sole negligence or acts or omissions by the COUNTY.

LESSEE shall notify COUNTY in the event of any accident or injury arising out of or in

003918

connection with this Agreement within forty-eight (48) hours after LESSEE's actual knowledge of such event.

21. **INSURANCE:** LESSEE shall carry and maintain for the duration of this Agreement insurance against claims for injuries to persons or damages to property which may arise from or in connection with the performance of the work hereunder and the results of that work by LESSEE, its agents, representatives, employees, contractors or subcontractors.

A. Scope of Insurance. Coverage shall be at least as broad as:

1. **Commercial General Liability (CGL):** Insurance Services Office (ISO) Form CG 00 01 covering CGL on an "occurrence" basis, including products-completed operations, personal & advertising injury, with limits of \$2,000,000 per occurrence and \$2,000,000 in the aggregate.
2. **Automobile Liability:** ISO Form Number CA 00 01 covering any auto (Code 1), or if LESSEE has no owned autos, hired, (Code 8) and non-owned autos (Code 9), with limit of \$2,000,000 per accident for bodily injury and property damage.
3. **Workers' Compensation:** as required by the State of California, with Statutory Limits, and Employer's Liability Insurance with limits of \$1,000,000 per accident for bodily injury or disease, policy limit.

B. Other Insurance Provisions. The required insurance policies are to contain, or be endorsed to contain, the following provisions:

1. **Additional Insured** – COUNTY, its officers, officials, employees, agents and volunteers are to be covered as additional insureds on the CGL policy by endorsement with respect to liability caused, in whole or in part, by work or operations performed by or on behalf of the LESSEE including materials, parts, or equipment furnished in connection with such work or operations. General liability coverage can be provided in the form of an endorsement to the LESSEE's insurance at least as broad as both CG 20 10 and CG 20 37.
2. **Primary Coverage** – For any claims related to this Agreement, the LESSEE's required insurance coverage shall be primary insurance as respects the COUNTY, its officers, officials, employees, agents and volunteers. Any insurance or self-insurance maintained by the COUNTY, its officers, officials, employees, agents or volunteers shall be excess of the LESSEE's required insurance and shall not contribute with it.
3. **Notice of Cancellation** – LESSEE shall provide at least 30 days prior written notice to the COUNTY of cancellation of any required coverage that is not replaced.
4. **Waiver of Subrogation Rights** – LESSEE hereby grants to COUNTY a waiver of any right to Workers' Compensation subrogation which any insurer of said LESSEE may acquire against the COUNTY by virtue of the payment of any loss under such insurance. LESSEE agrees to obtain any endorsement that may be necessary to effect this waiver of subrogation, but this provision applies regardless of whether or not the

003918

COUNTY has received a waiver of subrogation endorsement from the insurer.

5. **Acceptability of Insurers** – Unless otherwise approved by Risk Management, insurance shall be written by insurers eligible to do business in the State of California and with a minimum A.M. Best's Insurance Guide rating of "A- VII".
6. **Verification of Coverage** – LESSEE shall furnish the COUNTY with proof of insurance, original certificates and copies of the endorsements as required by this Agreement. The proof of insurance, certificates and endorsements are to be received by the COUNTY before work commences. However, failure to obtain the required documents prior to the work beginning shall not waive LESSEE's obligation to provide them. LESSEE shall furnish evidence of renewal of coverage throughout the term of the Agreement.
7. **Failure to Procure Coverage** – In the event that any policy of insurance required under this Agreement does not comply with the requirements, is not procured, or is canceled and not replaced, COUNTY has the right but not the obligation or duty to terminate the Agreement. Maintenance of required insurance coverage is a material element of the Agreement and failure to maintain or renew such coverage or to provide evidence of renewal may be treated by COUNTY as a material breach of contract.
8. **Subcontractors** – LESSEE shall endeavor to require and verify that all subcontractors while working hereunder maintain insurance that is reasonable and prudent, and LESSEE shall ensure that COUNTY is an additional insured on insurance required from subcontractors.
9. **Special Risks or Circumstances** – COUNTY reserves the right to modify these requirements, including limits, once per Term or Renewal Term, based on the nature of the risk, prior experience, insurer, coverage, or other special circumstances.
10. Notwithstanding the foregoing, LESSEE may, in its sole discretion, self insure any of the required insurance under the same terms as required by this Agreement. In the event LESSEE elects to self insure its obligation under this Agreement to include COUNTY as an additional insured, the following conditions apply: (i) COUNTY shall promptly and no later than thirty (30) days after notice thereof provide LESSEE with written notice of any claim, demand, lawsuit, or the like for which it seeks coverage pursuant to this Section and provide LESSEE with copies of any demands, notices, summonses, or legal papers received in connection with such claim, demand, lawsuit, or the like; (ii) COUNTY shall not settle any such claim, demand, lawsuit or the like without the prior written consent of LESSEE; and (iii) COUNTY shall reasonably cooperate with LESSEE in the defense of the claim, demand, lawsuit, or the like.

Except for indemnification pursuant to Section 20, INDEMNIFICATION, and Section 23, ENVIRONMENTAL IMPAIRMENT, neither party shall be liable to the other, or any of their respective agents, representatives, and employees, for any lost revenue, lost profits, loss of technology, rights or services, incidental, punitive, indirect, special or consequential damages,

003918

loss of data, or interruption or loss of use of service, even if advised of the possibility of such damages, whether under theory of contract, tort (including negligence), strict liability or otherwise.

Any change requiring additional types of insurance coverage or higher coverage limits must be made by amendment to this Agreement. LESSEE agrees to execute any such mutually agreeable amendment within thirty (30) days of receipt.

Any failure, actual or alleged, on the part of COUNTY to monitor or enforce compliance with any of the insurance and indemnification requirements will not be deemed as a waiver of any rights on the part of COUNTY.

22. **NONDISCRIMINATION:** LESSEE shall comply with COUNTY laws, rules and regulations regarding nondiscrimination as such are found in the Santa Barbara Code and as such may from time to time be amended. These provisions are incorporated herein as if they were fully set forth.

LESSEE's noncompliance with provisions of this section shall constitute a material breach of this Agreement and in addition to any other remedies provided by law, COUNTY shall have the right to terminate this Agreement and the interest hereby created without liability therefore.

23. **ENVIRONMENTAL IMPAIRMENT:** LESSEE shall comply with all applicable laws, regulations, rules, and orders regardless of when they become or became effective, including without limitation those relating to construction, grading, signing, health, safety, noise, environmental protection, waste disposal, water and air quality, and shall furnish satisfactory evidence of compliance upon request of COUNTY.

Should any discharge, leakage, spillage, emission, or pollution of any type occur upon or from the Property, Facility or Site due to LESSEE'S use and occupancy, LESSEE shall clean all property affected to the reasonable satisfaction of COUNTY and any governmental body having jurisdiction therefore. LESSEE shall indemnify, hold harmless, and defend COUNTY from and against all liability, claim, cost, and expense (including without limitation any fines, penalties, judgments, litigation costs, reasonable attorney's fees, and consulting engineering and construction costs) incurred by COUNTY as a result of LESSEE'S breach of this section, or as a result of any such discharge, leakage, spillage, emission or pollution due to LESSEE'S use and occupancy, regardless of whether such liability, cost or expense arises during or after the Term of this Agreement, except to the extent caused by the sole negligence or willful misconduct of COUNTY. COUNTY agrees to hold harmless and indemnify LESSEE from, and to assume all duties, responsibilities and liabilities at the sole cost and expense of COUNTY for, payment of penalties, sanctions, forfeitures, losses, costs or damages, and for responding to any claims, to the extent arising from subsurface or other contamination of the Property with hazardous substances prior to the effective date of this Agreement or from such contamination caused by the acts or omissions of the COUNTY during the Term.

LESSEE agrees that during all maintenance on the Property by COUNTY, while following the procedures and guidelines set forth by the Occupational Safety and Health Administration (OSHA) and the FCC implementing the National Environmental Policy Act of 1969, when

003918

continuing transmission is deemed unsafe for COUNTY personnel due to radiation (based upon standards promulgated by a federal or state governmental authority having jurisdiction over LESSEE), the affected transmitters of LESSEE will be turned off during such maintenance for so long as the unsafe condition exists. The earliest practicable notice will be given to LESSEE using the information in Section 26, NOTICES.

24. **TOXICS**: LESSEE shall not manufacture or generate hazardous wastes on or in the Facility, Site, Property, or surrounding property unless specifically authorized by this Agreement. LESSEE shall be fully responsible for any hazardous wastes, substances or materials as defined under federal, state or local law, regulation, or ordinance that are manufactured, generated, used, placed, disposed, stored, or transported by LESSEE, its agents, employees, or designees on or in the Facility, the Site, Property, or surrounding property during the Term of this Agreement and shall comply with and be bound by all applicable provisions of such federal, state, or local law, regulation, or ordinance dealing with such wastes, substances, or materials. LESSEE shall notify COUNTY and the appropriate governmental emergency response agency (ies) immediately in the event of any release or threatened release of any such wastes, substances or materials by LESSEE.

25. **COMPLIANCE WITH THE LAW**: LESSEE agrees to comply with all federal, state and local laws, orders, rules and regulations ("Laws") applicable to LESSEE's use of the Facility on the Property. COUNTY agrees to comply with all Laws relating to COUNTY'S ownership and use of the Property and any improvements on the Property.

26. **NOTICES**: Any notice to be given to the parties shall be in writing and shall be served, either personally or by mail, to the following:

COUNTY: County of Santa Barbara
General Services Department
1105 Santa Barbara Street
Santa Barbara, CA 93101
Attn: Real Property Manager
(805) 568-3070
realproperty@countyofsb.org

LESSEE: New Cingular Wireless, LLC
Re: Cell Site No.: CSL04176
Fixed Asset No. 10581720
1025 Lenox Park Blvd. NE
Atlanta, GA 30319
Attn: Network Real Estate
(877) 231-5447

With a copy to:

New Cingular Wireless, LLC

003918

AT&T Legal Department – Network Operations
Attn: Network Counsel
Re: Cell Site No.: CSL04176
Fixed Asset No. 10581720
208 South Akard Street
Dallas, TX 75202-4206

or to the parties at such other place as may be designated in writing. Such notices shall be served by depositing them addressed as set out above, postage prepaid, in the U.S. mail, reliable overnight courier, or by personal delivery. The date of delivery or refusal of delivery shall constitute the date of service. The telephone numbers included in this Section are for reference only and a phone call does not constitute official notice when such notice is required by this Agreement.

27. **DEFAULT:** Except as otherwise required herein, should LESSEE at any time fail to comply with any covenant contained herein, then LESSEE shall be in Default and COUNTY shall give written notice to LESSEE specifying the particulars of the Default and LESSEE shall promptly commence remedial action to cure the Default. Should such Default continue uncured for a period of thirty (30) calendar days from such notice, this Agreement shall terminate at the option of the COUNTY; unless the cure of a non-monetary Default shall reasonably take more than thirty (30) calendar days in which case LESSEE shall proceed with all due speed to cure the Default and shall have a reasonable time to effectuate its cure. Except as otherwise required herein, should COUNTY at any time fail to comply with any covenant contained herein, LESSEE shall give written notice to COUNTY specifying the particulars of the Default and COUNTY shall promptly commence remedial action to cure the Default. Should such Default continue uncured for a period of thirty (30) calendar days from such notice, this Agreement shall terminate at the option of the LESSEE; unless the cure of the Default shall reasonably take more than thirty (30) calendar days in which case COUNTY shall proceed with all due speed to cure the Default and shall have a reasonable time to effectuate its cure.

28. **REMEDIES:** In the event of a Default or breach, either party may exercise any right or remedy at law or in equity which such party may have by reason of such Default including but not limited to the following:

- A. Waive the Default in accordance with Section 29, WAIVER, herein below.
- B. Maintain this Agreement in full force and effect and recover whatever monetary loss (es) may have resulted from such Default.
- C. Terminate the Agreement in accordance with Section 31, TERMINATION.

29. **WAIVER:** It is understood and agreed that any waiver, express or implied of any term of this Agreement shall neither waive, nor be construed to waive the subsequent enforcement of any other term of this Agreement or any subsequent Default under Section 27, DEFAULT.

30. **AMENDMENTS:** This Agreement may only be amended by written consent of the parties and such changes shall be binding upon the heirs or successors of the parties.

003918

31. **TERMINATION**: This Agreement shall terminate and all rights of LESSEE shall cease and LESSEE shall quietly and peacefully deliver to COUNTY, possession and interest in the Site:

- A. Upon expiration or earlier termination of the Agreement as provided in Section 5, **TERM**; or
- B. After making all reasonable and good faith efforts to obtain applicable certificates, permits and approvals, if any of LESSEE'S applications for applicable certificates, permits and other approvals issued to LESSEE is canceled, expires, lapses, or is otherwise withdrawn or terminated by governmental authority so that LESSEE will no longer be able to use the Site for its intended purposes or the LESSEE reasonably and in good faith determines that the Site is no longer economically or technologically feasible for its intended use. Such termination shall be effective upon written notice to COUNTY in writing by certified mail, return receipt requested, and shall be effective upon receipt of such notice by COUNTY; provided, however, that LESSEE must provide COUNTY with 12 months written notice of its intention to terminate this Agreement for economic or technological reasons; or
- C. In accordance with Section 41, **CONDEMNATION**; or
- D. If LESSEE is adjudged bankrupt, in accordance with Section 42, **BANKRUPTCY**.

This Agreement may also terminate:

- AA. At LESSEE's option in accordance with Subsection 14.E, "Relocation"; or
- BB. At COUNTY's option if LESSEE fails to comply with COUNTY laws, rules and regulations regarding nondiscrimination as provided in Section 22, **NONDISCRIMINATION**; or
- CC. At the option of the nondefaulting party at the end of the cure period in accordance with Section 27, **DEFAULT**; or
- DD. At the option of either party in accordance with Section 32, **DESTRUCTION**.

Upon termination of this Agreement pursuant to Section 31, **TERMINATION**, all rights of LESSEE to the Site shall cease and LESSEE shall quietly and peacefully deliver to COUNTY, possession and interest in the Site in accordance with Section 35, **SURRENDER OF PREMISES**.

32. **DESTRUCTION**: If the Facility or the Site is partially or totally destroyed by fire or other casualty, this Agreement, at the option of COUNTY or LESSEE, shall terminate.

33. **HOLDING OVER**: Should LESSEE occupy the Site after the expiration date of this Agreement or any extension thereof, with the consent of the COUNTY, expressed or implied, such possession shall be construed to be a tenancy from month to month and LESSEE shall pay COUNTY for such tenancy at the monthly rental rate in effect on the expiration date.

34. **AGENCY DISCLOSURE**: LESSEE acknowledges that the General Services Department, Facilities Services Division, of the COUNTY is the agent for the COUNTY exclusively, and is neither the agent for LESSEE nor a dual agent in this transaction.

003918

35. **SURRENDER OF PREMISES:** Upon expiration or termination of this Agreement, LESSEE shall vacate and surrender possession of, and any claim to the Site, leaving it in good condition, except for ordinary wear and tear.

Notwithstanding the foregoing and subject to Section 12, **TITLE TO FACILITY,** LESSEE shall remove LESSEE'S Owned Facilities up to five (5) feet below grade within sixty (60) days prior to the date of such expiration or within sixty (60) days after the earlier termination of this Agreement and LESSEE shall retain title to LESSEE'S Owned Facilities. Alternatively, upon such expiration or termination, COUNTY may request in writing at least ninety (90) days prior to such expiration or within ninety (90) days after the earlier termination of this Agreement the removal of the Facility up to five (5) feet below grade, in whole or in part, and if COUNTY so requests, LESSEE shall remove or have said Facility (including LESSEE'S Owned Facilities) or such lesser portions as COUNTY may request removed as soon as is practicable, at LESSEE'S sole cost.

Upon completion of LESSEE'S removal of its Facility, LESSEE shall obtain COUNTY's approval, not to be unreasonably withheld, conditioned or delayed, that said Facility has been removed and the Site restored to good condition.

36. **CAPTIONS:** The title or headings to the sections of this Agreement are not a part of this Agreement, and shall have no effect upon the construction or interpretation of any part hereof.

37. **SEVERABILITY:** If any one or more of the provisions contained herein shall for any reason be held to be invalid, illegal, or unenforceable in any respect, then such provision or provisions shall be deemed severable from the remaining provisions hereof, and such invalidity, illegality, or unenforceability shall not affect any other provision hereof, and this Agreement shall be construed as if such invalid, illegal, or unenforceable provision had never been contained herein.

38. **CERTIFICATION OF SIGNATORY:** The signatories of this Agreement and each of them represent and warrant that they are authorized to execute this Agreement and that no additional signatures are required to bind COUNTY and LESSEE to its terms and conditions or to carry out duties contemplated herein.

39. **PERMITTED PERSONNEL:** LESSEE shall be solely liable for all actions of its agents, employees, contractors, subcontractors, and any others it permits on the Property or Site and shall be responsible for any and all damages resulting from their actions.

40. **FIRE DAMAGE:** LESSEE agrees to hold COUNTY harmless and indemnify COUNTY from any damage or injury to COUNTY, other persons or to property resulting from any fire caused by LESSEE, its agents, employees, or permittees, except to the extent such fire is caused by the sole acts or omissions of COUNTY.

41. **CONDEMNATION:** In the event the Property or any part thereof is taken by condemnation, eminent domain, or any such proceeding that precludes access to or use of the Site, COUNTY shall have the exclusive right to control the defense of any such action in condemnation

003918

or eminent domain and to defend any such action and settle the same in COUNTY'S absolute discretion. LESSEE agrees that COUNTY shall have the right, but not the obligation, to defend or settle any such action in condemnation or eminent domain affecting any of LESSEE'S installations at the Site.

LESSEE shall receive from COUNTY such proportionate amount of the judgment, award, or settlement as shall be attributable to LESSEE'S interests.

In the event that full or partial possession of the Site is obtained by a public agency or other agency empowered to take by eminent domain, in a manner which precludes LESSEE'S intended use, this Agreement shall terminate as of the effective date of possession and upon such termination, any obligation of LESSEE to pay Rent shall cease with the payment of the prorated portion of rental obligations up to said termination date. Any prepaid Rent shall be returned to LESSEE from the effective date of termination.

In the event of a partial taking, this Agreement may continue at COUNTY'S option and with the consent of LESSEE, however, Rent hereunder may be reduced proportionately.

42. **BANKRUPTCY:** If LESSEE is adjudged bankrupt, this Agreement shall immediately terminate and the same shall not be treated as an asset of LESSEE after such adjudication, nor shall it pass to the control of any trustee or assignee of LESSEE by virtue of any process in bankruptcy or insolvency by execution or attachment.

43. **CONSTRUCTION:** The parties to this Agreement agree that each party and its respective counsel have reviewed and approved this Agreement to the extent that each party in its sole discretion has desired, and that any rule of construction to the effect that ambiguities are to be resolved against the drafting party shall not apply in the interpretation of this Agreement. The terms and conditions of this Agreement embody the parties' mutual intent, and this Agreement shall not be construed more liberally in favor of, nor more strictly against any party hereto.

44. **FACSIMILE SIGNATURES:** In the event that the parties hereto utilize facsimile transmitted documents which include signatures, such documents shall be accepted as if they bore original signatures provided that documents bearing ORIGINAL SIGNATURES are provided within seventy-two (72) hours of transmission of the facsimile, except that funds shall not be released upon a facsimile signature nor shall facsimile signed documents be accepted for recordation by the Clerk Recorder of the County.

45. **EXECUTION IN COUNTERPARTS:** This Agreement may be executed in any number of counterparts and each such counterpart shall for all purposes be deemed to be an original; and all such counterparts, or as many of them as the parties shall preserve undestroyed, shall together constitute one and the same instrument.

46. **ENTIRE AGREEMENT:** The parties to this Agreement intend that their negotiations, conversations and statements made prior to execution of this Agreement are fully integrated and expressed herein, and no such negotiations, conversations, and statements shall be deemed to create rights or obligations other than those stated herein.

[SIGNATURE PAGE FOLLOWS]

Project: AT&T at Vandenberg Hills
Little League
APN: 097-371-051 (Portion)
Folio: 003918
Agent: JJS

IN WITNESS WHEREOF, COUNTY and LESSEE have executed this Agreement by the respective authorized officers as set forth below to be effective as of the date executed by COUNTY.

"COUNTY"
COUNTY OF SANTA BARBARA

ATTEST:
MONA MIYASATO
CLERK OF THE BOARD

By: *Shirley LaGuerra*
Deputy

By: *Bob Nelson*
Name: Bob Nelson
Title: Chair, Board of Supervisors

Date: 4/20/2021

APPROVED AS TO ACCOUNTING:
BESTY M. SCHAFER, CPA, CPFO
AUDITOR-CONTROLLER

By: *[Signature]*
Deputy

"LESSEE"
New Cingular Wireless PCS, LLC,
a Delaware limited liability company

By: *Misty Snowden*
Name: Misty Snowden
Title: Area Manager
Date: 3/26/21

APPROVED AS TO FORM:
MICHAEL C. GHIZZONI
COUNTY COUNSEL

By: *[Signature]*
Deputy

APPROVED:
Carlo Achdjian
Carlo Achdjian, Manager
Real Estate Services Division

APPROVED AS TO INSURANCE FORM:
Ray Aromatorio
Ray Aromatorio, ARM, AIC
Risk Program Administrator

“PROPERTY”
Exhibit “A”

“SITE”
Exhibit “B”

“ARCHITECTURAL PLANS”
Exhibit “C”

“EQUIPMENT AND ANTENNA SPECIFICATIONS”
Exhibit “D”

“LAND USE PERMITS”
Exhibit “E”

EXHIBIT A

SITE PLAN

NOTES
 1. THIS SITE PLAN IS SUBJECT TO THE CITY OF ALBERTA'S DEVELOPMENT REVIEW PROCESS AND THE CITY OF ALBERTA'S ZONING ORDINANCE. THE CITY OF ALBERTA'S DEVELOPMENT REVIEW PROCESS IS A PUBLIC PROCESS AND THE CITY OF ALBERTA'S ZONING ORDINANCE IS A PUBLIC DOCUMENT. THE CITY OF ALBERTA'S DEVELOPMENT REVIEW PROCESS AND THE CITY OF ALBERTA'S ZONING ORDINANCE ARE SUBJECT TO CHANGE WITHOUT NOTICE. THE CITY OF ALBERTA'S DEVELOPMENT REVIEW PROCESS AND THE CITY OF ALBERTA'S ZONING ORDINANCE ARE SUBJECT TO CHANGE WITHOUT NOTICE.

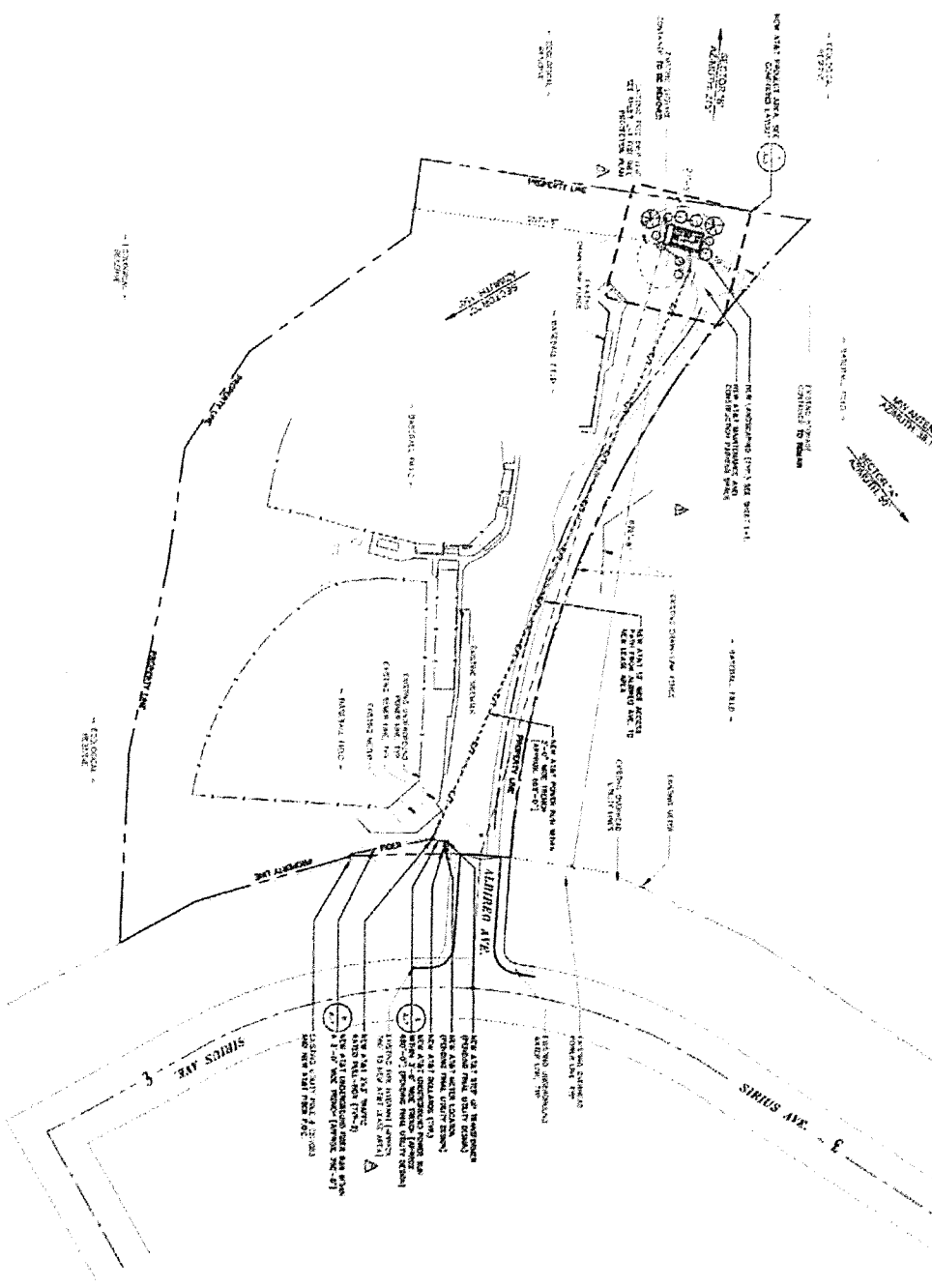

SCALE: 1" = 20'

A-1

SITE PLAN

330 ALBERTA AVE,
 COMPOC, CA 95136

Eukon
 485 POST STATE 1000
 BERKELEY, CA 94704
 TEL: (415) 524-8989
 WWW.EUKON.COM

NO.	DESCRIPTION	DATE	BY
1	PRELIMINARY SITE PLAN	01/21/00	J. HARRIS
2	REVISED SITE PLAN	02/10/00	J. HARRIS
3	FINAL SITE PLAN	02/10/00	J. HARRIS

at&t
 THE NEW
 1442 TOWER AVE., 3RD FLOOR
 THERM, CA 95128

Eukon
 485 POST STATE 1000
 BERKELEY, CA 94704
 TEL: (415) 524-8989
 WWW.EUKON.COM

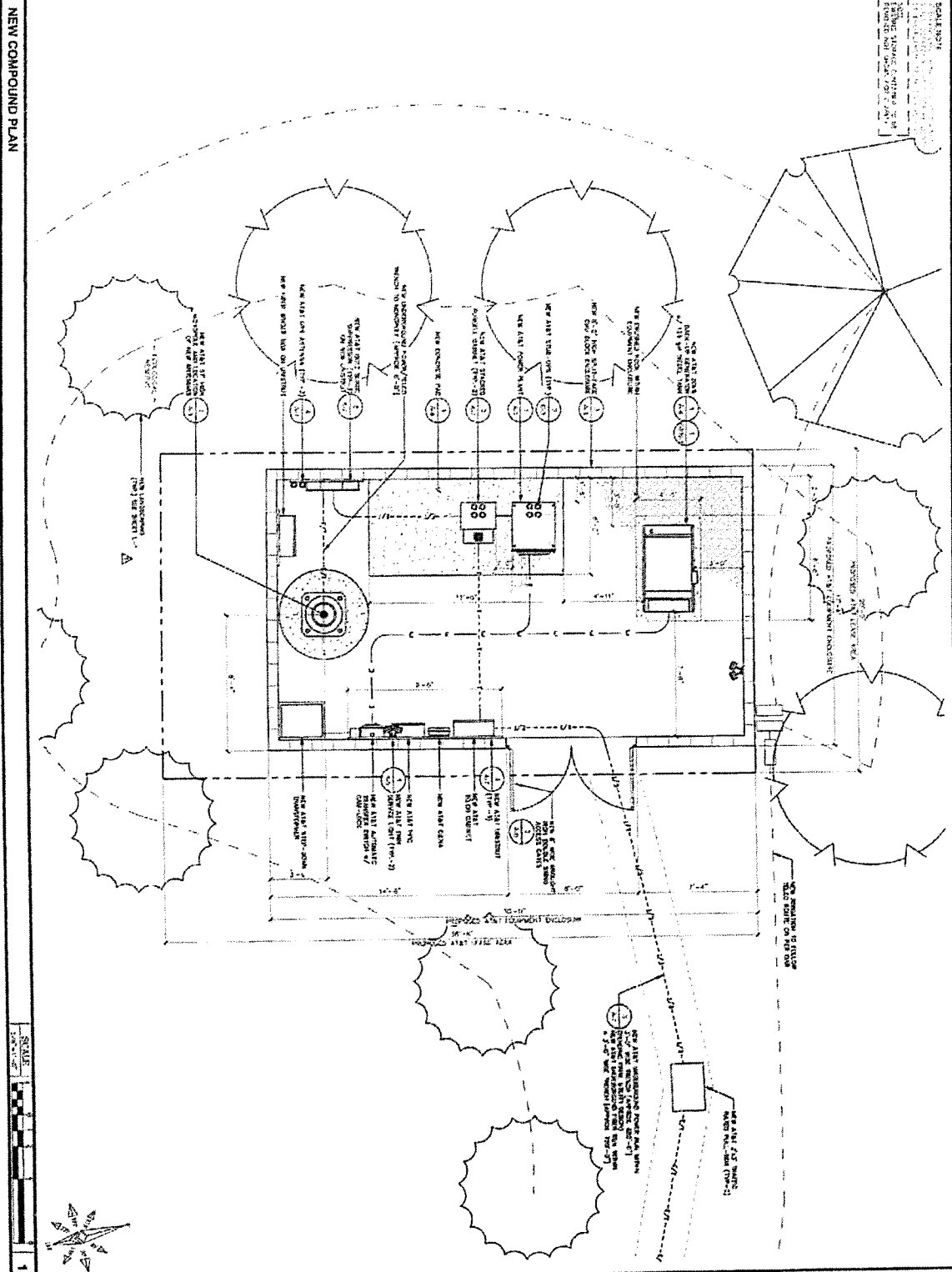

SCALE: 1/8" = 1'-0"
 ALL DIMENSIONS ARE IN FEET AND INCHES
 DIMENSIONS NOT SHOWN SHALL BE AS SHOWN

NEW COMPOUND PLAN



 THE NEW at&t 1452 CONCRETE PK. S. 2ND FLOOR COSTA MESA, CA 92626	ENGINEER Eukon 65 POST SAGE TOWER IRVINE, CA 92618 TEL: (949) 555-8555 www.eukon.com
CONTRACT NO. PROJECT NO.	SHEET NO.
DATE ISSUED: 11/15/06 NO. OF SHEETS: 17	SHEET TITLE NEW COMPOUND
CONTRACTOR: 530 ALBERD AVE. LIVERMORE, CA 94550	DRAWN BY: CHECKED BY: DATE:
	SHEET TITLE A-2

APPROVALS

ENGINEERING

SITE INFORMATION

PROJECT TEAM



SITE NUMBER: CSL04176
PAGE#: MRLOS050508
FA#: 10581720
USID#: 219238

PROJECT: NEW SITE BUILD
SITE TYPE: RAWLAND
SITE ADDRESS: 300 ALBIRO AV.
LOMPOC, CA 93436

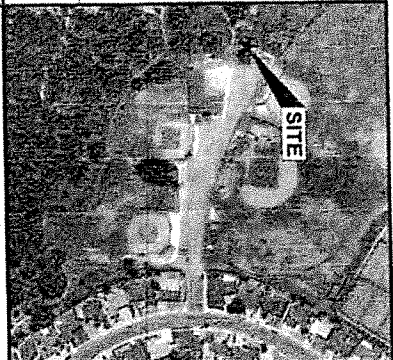
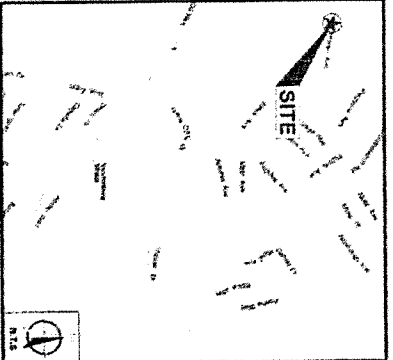

VICINITY MAP

AERIAL MAP

GENERAL NOTES

DO NOT SCALE DRAWINGS

PROJECT DESCRIPTION

IF QUOTE "AT&T" CALL, STANDARD WILL BE HALF SCALE

CONSTRUCTION DRAWING

NO.	DESCRIPTION	REV.
1	FINAL SHEET	0
2	GENERAL NOTES LISTED AND ADDITIONS	0
3	GENERAL NOTES	0
4	STATISTICS OF SPECIAL NOTATIONS	0
5	SITE PLAN	0
6	SITE ELEVATION	0
7	GENERAL NOTES	0
8	GENERAL NOTES	0
9	GENERAL NOTES	0
10	GENERAL NOTES	0
11	GENERAL NOTES	0
12	GENERAL NOTES	0
13	GENERAL NOTES	0
14	GENERAL NOTES	0
15	GENERAL NOTES	0
16	GENERAL NOTES	0
17	GENERAL NOTES	0
18	GENERAL NOTES	0
19	GENERAL NOTES	0
20	GENERAL NOTES	0
21	GENERAL NOTES	0
22	GENERAL NOTES	0
23	GENERAL NOTES	0
24	GENERAL NOTES	0
25	GENERAL NOTES	0
26	GENERAL NOTES	0
27	GENERAL NOTES	0
28	GENERAL NOTES	0
29	GENERAL NOTES	0
30	GENERAL NOTES	0
31	GENERAL NOTES	0
32	GENERAL NOTES	0
33	GENERAL NOTES	0
34	GENERAL NOTES	0
35	GENERAL NOTES	0
36	GENERAL NOTES	0
37	GENERAL NOTES	0
38	GENERAL NOTES	0
39	GENERAL NOTES	0
40	GENERAL NOTES	0
41	GENERAL NOTES	0
42	GENERAL NOTES	0
43	GENERAL NOTES	0
44	GENERAL NOTES	0
45	GENERAL NOTES	0
46	GENERAL NOTES	0
47	GENERAL NOTES	0
48	GENERAL NOTES	0
49	GENERAL NOTES	0
50	GENERAL NOTES	0
51	GENERAL NOTES	0
52	GENERAL NOTES	0
53	GENERAL NOTES	0
54	GENERAL NOTES	0
55	GENERAL NOTES	0
56	GENERAL NOTES	0
57	GENERAL NOTES	0
58	GENERAL NOTES	0
59	GENERAL NOTES	0
60	GENERAL NOTES	0
61	GENERAL NOTES	0
62	GENERAL NOTES	0
63	GENERAL NOTES	0
64	GENERAL NOTES	0
65	GENERAL NOTES	0
66	GENERAL NOTES	0
67	GENERAL NOTES	0
68	GENERAL NOTES	0
69	GENERAL NOTES	0
70	GENERAL NOTES	0
71	GENERAL NOTES	0
72	GENERAL NOTES	0
73	GENERAL NOTES	0
74	GENERAL NOTES	0
75	GENERAL NOTES	0
76	GENERAL NOTES	0
77	GENERAL NOTES	0
78	GENERAL NOTES	0
79	GENERAL NOTES	0
80	GENERAL NOTES	0
81	GENERAL NOTES	0
82	GENERAL NOTES	0
83	GENERAL NOTES	0
84	GENERAL NOTES	0
85	GENERAL NOTES	0
86	GENERAL NOTES	0
87	GENERAL NOTES	0
88	GENERAL NOTES	0
89	GENERAL NOTES	0
90	GENERAL NOTES	0
91	GENERAL NOTES	0
92	GENERAL NOTES	0
93	GENERAL NOTES	0
94	GENERAL NOTES	0
95	GENERAL NOTES	0
96	GENERAL NOTES	0
97	GENERAL NOTES	0
98	GENERAL NOTES	0
99	GENERAL NOTES	0
100	GENERAL NOTES	0

SHEET INDEX

NO.	TITLE SHEET	DATE
1	GENERAL NOTES	
2	GENERAL NOTES	
3	GENERAL NOTES	
4	GENERAL NOTES	
5	GENERAL NOTES	
6	GENERAL NOTES	
7	GENERAL NOTES	
8	GENERAL NOTES	
9	GENERAL NOTES	
10	GENERAL NOTES	
11	GENERAL NOTES	
12	GENERAL NOTES	
13	GENERAL NOTES	
14	GENERAL NOTES	
15	GENERAL NOTES	
16	GENERAL NOTES	
17	GENERAL NOTES	
18	GENERAL NOTES	
19	GENERAL NOTES	
20	GENERAL NOTES	
21	GENERAL NOTES	
22	GENERAL NOTES	
23	GENERAL NOTES	
24	GENERAL NOTES	
25	GENERAL NOTES	
26	GENERAL NOTES	
27	GENERAL NOTES	
28	GENERAL NOTES	
29	GENERAL NOTES	
30	GENERAL NOTES	
31	GENERAL NOTES	
32	GENERAL NOTES	
33	GENERAL NOTES	
34	GENERAL NOTES	
35	GENERAL NOTES	
36	GENERAL NOTES	
37	GENERAL NOTES	
38	GENERAL NOTES	
39	GENERAL NOTES	
40	GENERAL NOTES	
41	GENERAL NOTES	
42	GENERAL NOTES	
43	GENERAL NOTES	
44	GENERAL NOTES	
45	GENERAL NOTES	
46	GENERAL NOTES	
47	GENERAL NOTES	
48	GENERAL NOTES	
49	GENERAL NOTES	
50	GENERAL NOTES	
51	GENERAL NOTES	
52	GENERAL NOTES	
53	GENERAL NOTES	
54	GENERAL NOTES	
55	GENERAL NOTES	
56	GENERAL NOTES	
57	GENERAL NOTES	
58	GENERAL NOTES	
59	GENERAL NOTES	
60	GENERAL NOTES	
61	GENERAL NOTES	
62	GENERAL NOTES	
63	GENERAL NOTES	
64	GENERAL NOTES	
65	GENERAL NOTES	
66	GENERAL NOTES	
67	GENERAL NOTES	
68	GENERAL NOTES	
69	GENERAL NOTES	
70	GENERAL NOTES	
71	GENERAL NOTES	
72	GENERAL NOTES	
73	GENERAL NOTES	
74	GENERAL NOTES	
75	GENERAL NOTES	
76	GENERAL NOTES	
77	GENERAL NOTES	
78	GENERAL NOTES	
79	GENERAL NOTES	
80	GENERAL NOTES	
81	GENERAL NOTES	
82	GENERAL NOTES	
83	GENERAL NOTES	
84	GENERAL NOTES	
85	GENERAL NOTES	
86	GENERAL NOTES	
87	GENERAL NOTES	
88	GENERAL NOTES	
89	GENERAL NOTES	
90	GENERAL NOTES	
91	GENERAL NOTES	
92	GENERAL NOTES	
93	GENERAL NOTES	
94	GENERAL NOTES	
95	GENERAL NOTES	
96	GENERAL NOTES	
97	GENERAL NOTES	
98	GENERAL NOTES	
99	GENERAL NOTES	
100	GENERAL NOTES	

PROJECT

1433 DOWNEY AVE, 3RD FLOOR
 IRVINE, CA 92614
 TEL: (949) 955-8800
www.atandt.com

PROJECT

10122 Commercial Center, Suite 100
 IRVINE, CA 92618
 TEL: (949) 255-8800
www.euikon.com

PROJECT

CITY OF LOMPOC
 300 ALBIRO AVE.
 LOMPOC, CA 93436

SHEET TITLE

TITLE SHEET

6/27/2009

T-1

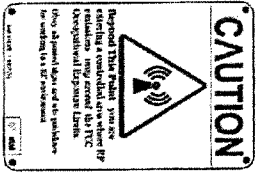
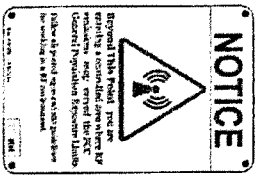

ALERTING SIGNS
NO. 500-1

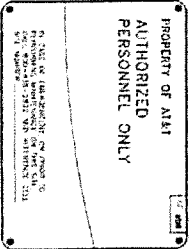
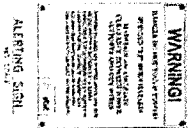
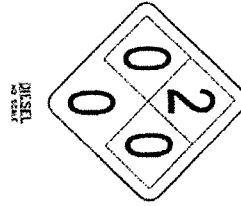
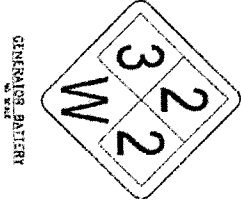

INFO. SIGN #5



INFO. SIGN #3



INFO. SIGN #2



INFO. SIGN #4

S T A Y B A C K 3 F E E T F R O M A N T E N N A

GENERAL SIGNAGE GUIDELINES

Signage	DESCRIPTION	PLACEMENT	HEIGHT	SPACING	NOTES	CAUTIONS
TOWERS	Signage used to identify towers and structures.	On the side of the tower.	Minimum 10 feet.	Minimum 10 feet.	Signage must be placed on all sides of the tower.	Signage must be placed on all sides of the tower.
Road Signs	Signage used to identify roads and structures.	On the side of the road.	Minimum 10 feet.	Minimum 10 feet.	Signage must be placed on all sides of the road.	Signage must be placed on all sides of the road.
Church Steeple	Signage used to identify church steeples.	On the side of the steeple.	Minimum 10 feet.	Minimum 10 feet.	Signage must be placed on all sides of the steeple.	Signage must be placed on all sides of the steeple.
Water Towers	Signage used to identify water towers.	On the side of the tower.	Minimum 10 feet.	Minimum 10 feet.	Signage must be placed on all sides of the tower.	Signage must be placed on all sides of the tower.

GENERAL SIGNAGE GUIDELINES CHART

PRINTED INFORMATION

3304176
300 ABERDEEN AVE
LONDON, CA 94039

DATE ORDERED: 11/18/82

ORDER NO.

NO. 500-1

GENERAL SIGNAGE

T-3

THE NEW at&t

1451 CONVERSE AVE. 3RD FLOOR
SUNNYVALE, CA 95086

Eukon

55 FORT STUYVE 1000
SUNNYVALE, CA 95086
TELEPHONE: 415-555-6995
FAX: 415-555-6995

STATEMENT OF SPECIAL INSPECTIONS

NO.	DESCRIPTION OF THE SPECIAL INSPECTION	DATE	INSPECTOR
1	INSPECTION OF THE ...		
2	INSPECTION OF THE ...		
3	INSPECTION OF THE ...		
4	INSPECTION OF THE ...		
5	INSPECTION OF THE ...		
6	INSPECTION OF THE ...		
7	INSPECTION OF THE ...		
8	INSPECTION OF THE ...		
9	INSPECTION OF THE ...		
10	INSPECTION OF THE ...		
11	INSPECTION OF THE ...		
12	INSPECTION OF THE ...		
13	INSPECTION OF THE ...		
14	INSPECTION OF THE ...		
15	INSPECTION OF THE ...		
16	INSPECTION OF THE ...		
17	INSPECTION OF THE ...		
18	INSPECTION OF THE ...		
19	INSPECTION OF THE ...		
20	INSPECTION OF THE ...		

FROM: [Name]

TO: [Name]

DATE: [Date]

RE: [Subject]

1. I am writing to you regarding the ...

2. The ...

3. ...

4. ...

5. ...

6. ...

7. ...

8. ...

9. ...

10. ...

11. ...

12. ...

13. ...

14. ...

15. ...



16. ...

17. ...

18. ...

19. ...

20. ...

 <p>at&t</p> <p>1455 FORD AVE., 3RD FLOOR FURNING, CA 95131</p>	 <p>Eukon</p> <p>68 POST STATE 1920 FURNING, CA 95131 TEL: (916) 924-8896 www.eukon.com</p>	 <p>REGISTERED ARCHITECT</p> <p>ARCHITECT/COMMITTEE</p> <p>CASQUITA 300 ALBERT AVE. LINDSEY, CA 95136</p>	<p>STATE TITLE</p> <p>STATEMENT OF SPECIAL INSPECTIONS</p> <p>STATE NUMBER</p> <p>T-4</p>
--	---	--	--

SCALE NOTE

1" = 100' (AS SHOWN ON THIS PLAN)
1" = 200' (AS SHOWN ON THIS PLAN)
1" = 400' (AS SHOWN ON THIS PLAN)

SITE PLAN

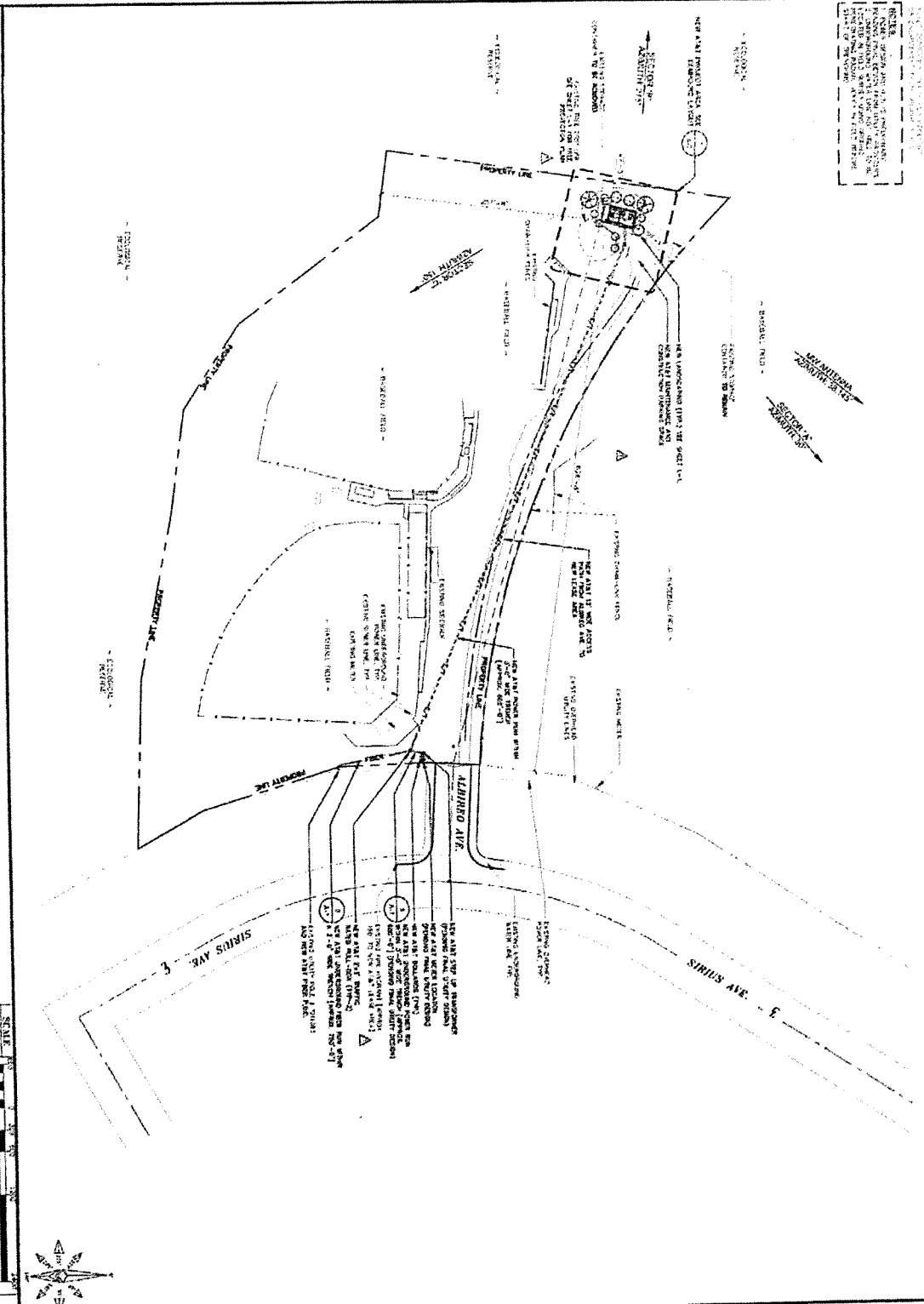

<p>NEW 1421 BOWEN ST. 3RD FLOOR LOS ANGELES, CA 90017</p>	<p>DATE: 11/20/00</p> <p>PROJECT: 111120</p> <p>PROJECT: 111120</p>	<p>CONTRACT NO.</p> <p>REVISIONS</p>	<p>PROJECT: 111120</p> <p>PROJECT: 111120</p>	<p>DATE: 11/20/00</p> <p>PROJECT: 111120</p>	<p>1421 BOWEN ST. 3RD FLOOR LOS ANGELES, CA 90017</p> <p>TEL: (888) 555-5555</p> <p>WWW.ATANDT.COM</p>
	<p>CONTRACT NO.</p> <p>REVISIONS</p>	<p>PROJECT: 111120</p> <p>PROJECT: 111120</p>	<p>DATE: 11/20/00</p> <p>PROJECT: 111120</p>	<p>1421 BOWEN ST. 3RD FLOOR LOS ANGELES, CA 90017</p> <p>TEL: (888) 555-5555</p> <p>WWW.ATANDT.COM</p>	

SCALE NOTE
 ALL DIMENSIONS ARE IN FEET AND INCHES
 UNLESS OTHERWISE NOTED

NEW COMPOUND PLAN

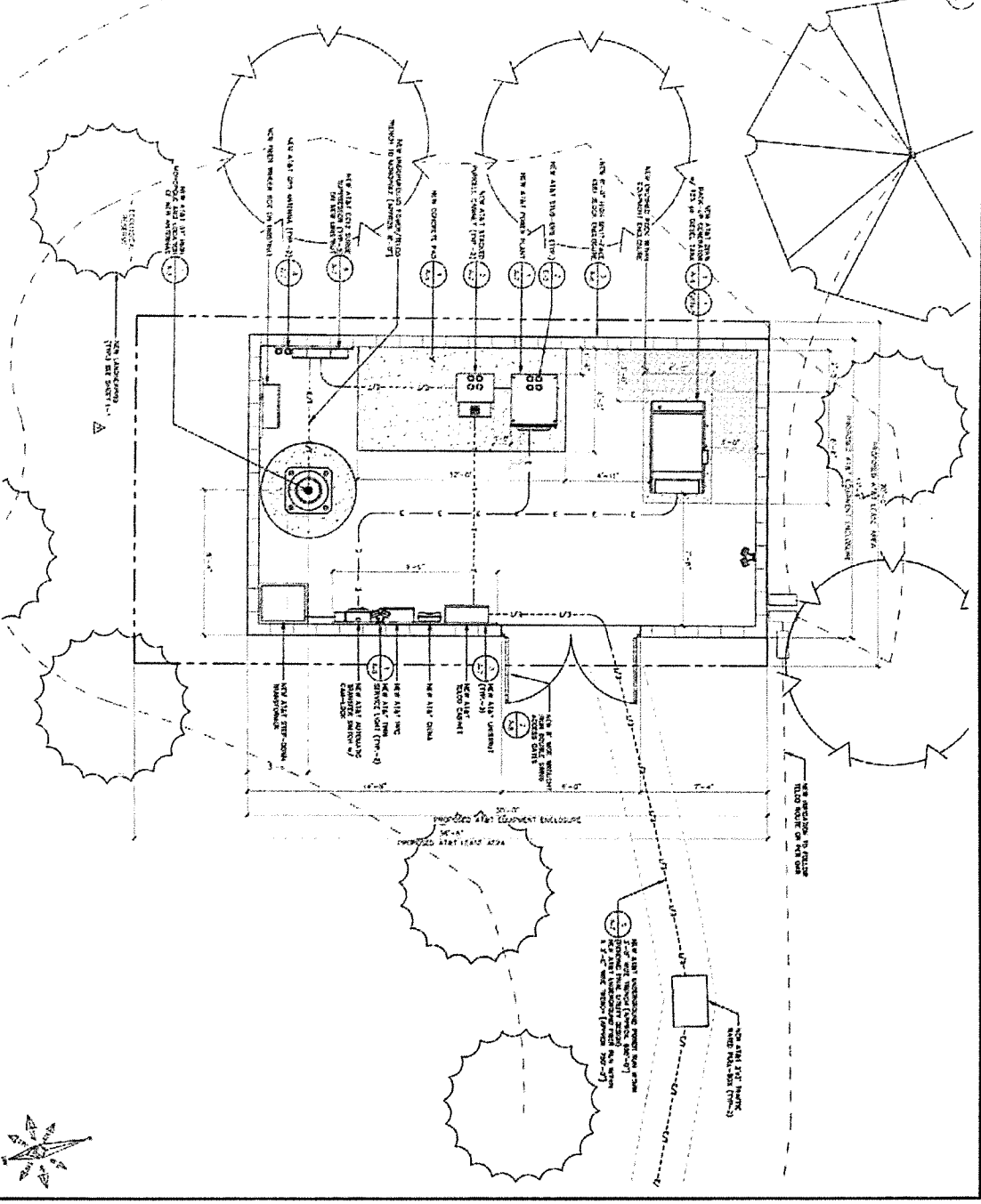

SCALE: 1/8" = 1'-0"



at&t
 THE NEW
 1-800-833-8388
 IRVING, TX 75039

Eukon
 8300 S. GULF Fwy.
 P.O. BOX 11111
 HOUSTON, TX 77241
 TEL. (713) 554-8999
 WWW.EUKON.COM

NO.	DESCRIPTION	DATE
1	ISSUED FOR PERMITS	05/18/00
2	REVISED PER COMMENTS	05/18/00
3	REVISED PER COMMENTS	05/18/00
4	REVISED PER COMMENTS	05/18/00
5	REVISED PER COMMENTS	05/18/00
6	REVISED PER COMMENTS	05/18/00
7	REVISED PER COMMENTS	05/18/00
8	REVISED PER COMMENTS	05/18/00
9	REVISED PER COMMENTS	05/18/00
10	REVISED PER COMMENTS	05/18/00
11	REVISED PER COMMENTS	05/18/00
12	REVISED PER COMMENTS	05/18/00
13	REVISED PER COMMENTS	05/18/00
14	REVISED PER COMMENTS	05/18/00
15	REVISED PER COMMENTS	05/18/00
16	REVISED PER COMMENTS	05/18/00
17	REVISED PER COMMENTS	05/18/00
18	REVISED PER COMMENTS	05/18/00
19	REVISED PER COMMENTS	05/18/00
20	REVISED PER COMMENTS	05/18/00

DATE PLOTTED: 11/08/00
 PROJECT: EXHIBITION
 05.08.0178
 309 ABRAMO AVE.
 LOS FOLIOS, TX 75456

NEW COMPOUND
 4-4117-00000

A-2

SCALE: 1/8" = 1'-0"

NEW SOUTHEAST ELEVATION

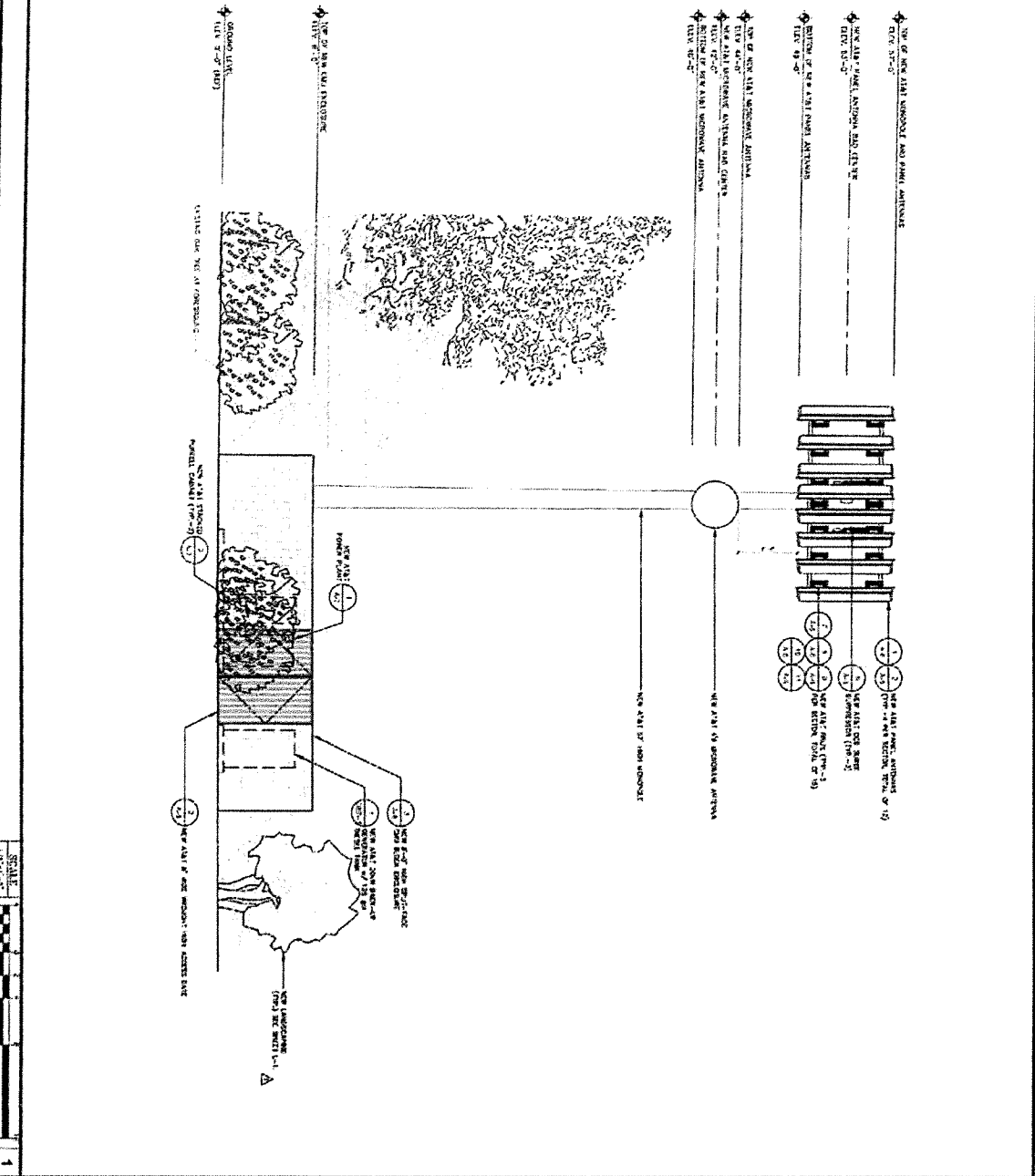

<p>WORKSHEET</p> <p>1407 DORSET AVE., 3RD FLOOR IRVINE, CA 92618</p> <p>at&t</p>	<p>OWNER: Eukon</p> <p>15700 DORSET AVE. 3RD FLOOR IRVINE, CA 92618 TEL: (949) 853-8899 www.eukon.com</p>	<p>DATE: 10/10/00</p> <p>SCALE: 1/8" = 1'-0"</p> <p>PROJECT: NEW SOUTHEAST ELEVATION</p> <p>DESIGNER: [Signature]</p>	<p>DATE: 10/10/00</p> <p>SCALE: 1/8" = 1'-0"</p> <p>PROJECT: NEW SOUTHEAST ELEVATION</p> <p>DESIGNER: [Signature]</p>	<p>300 CALIFORNIA AVE. LONDON, CA 94038</p>	<p>NEW SOUTHEAST ELEVATION</p>	<p>A-4</p>
---	---	---	---	---	--------------------------------	------------

SCALE NOTE
 1" = 10'-0"
 1/4" = 3'-0"
 1/8" = 6'-0"
 1/16" = 12'-0"

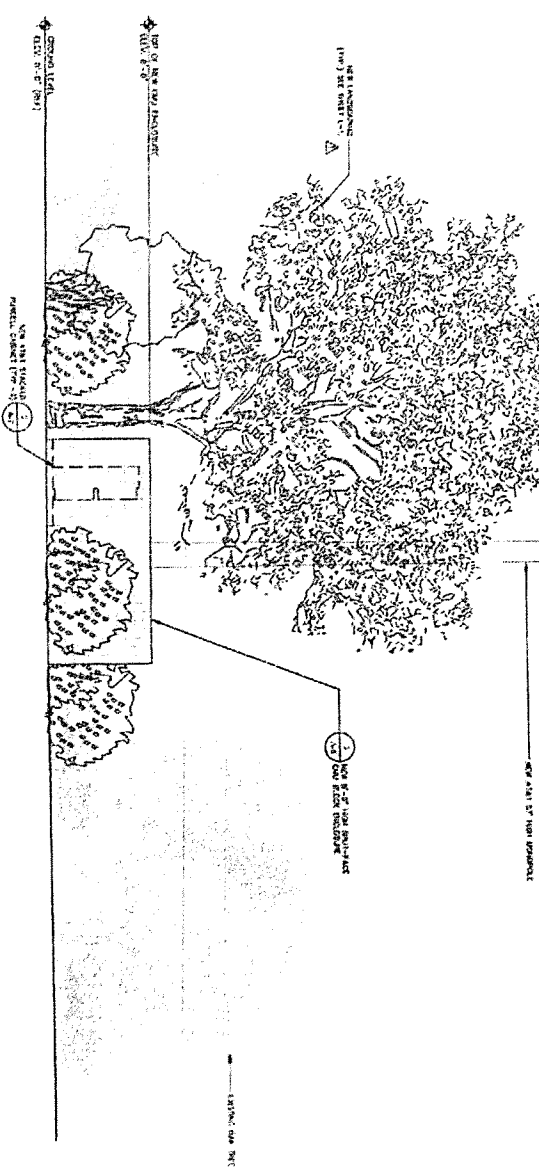
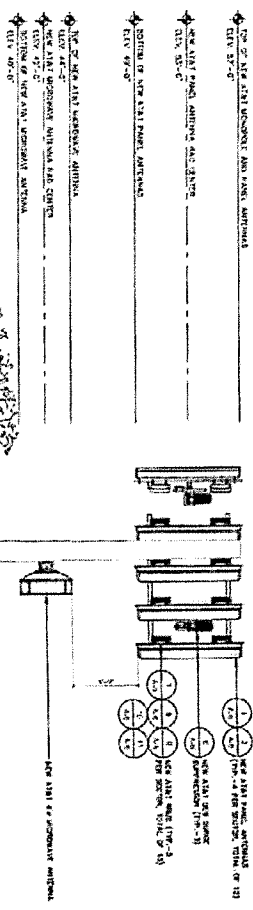

NEW SOUTHWEST ELEVATION



THE NEW at&t
 1422 BROADWAY, SUITE 1200
 DUBLIN, CA 94568

Eukon
 65 POST WAYE 1000
 IRVINE, CA 92618
 TEL: (949) 558-8888
 www.eukon.com

NO.	REVISION	DATE
1	ISSUED FOR PERMIT	08/20/08
2	REVISED PER COMMENTS	08/20/08
3	REVISED PER COMMENTS	08/20/08
4	REVISED PER COMMENTS	08/20/08
5	REVISED PER COMMENTS	08/20/08
6	REVISED PER COMMENTS	08/20/08
7	REVISED PER COMMENTS	08/20/08
8	REVISED PER COMMENTS	08/20/08
9	REVISED PER COMMENTS	08/20/08
10	REVISED PER COMMENTS	08/20/08

DATE ISSUED: 11/20/08
 PROJECT: 0804176
 PROJECT: 0804176
 300 ALBERO AVE.
 LOMBOD, CA 94136

PROJECT TITLE:
 NEW SOUTHWEST
 ELEVATION

1
 A-5

<p>KATHREIN - RUC-0983K</p>	<p>QUINTEL - CS8959-3a</p>	<p>ANTENNA MOUNTING</p>	<p>RRU MOUNTING</p> <p>ERICSSON BASEBAND - 6930</p>
<p>ANTENNA</p> <p>RAYCAF CCA-49-002449C-EV</p>	<p>ANTENNA</p> <p>ERICSSON RRUS - 4415 B30</p>	<p>ANTENNA MOUNTING</p> <p>ERICSSON RRUS - 4478 B14</p>	<p>ERICSSON RRUS - 9913 B27666A</p>
<p>DC SURGE SUPPRESSION</p>	<p>RRU-E2 B29</p> <p>ERICSSON RRU-E2 B29</p>	<p>RRU-4478 B14</p> <p>ERICSSON RRU-4478 B14</p>	<p>RRU-9843 B27666A</p> <p>ERICSSON BASEBAND - 5216</p>

<p>AT&T</p> <p>1425 GEMBLE AVE., 3RD FLOOR IRVINE, CA 92714</p>	<p>Eukon</p> <p>35100 BAYVIEW BLVD. IRVINE, CA 92618 TEL: (949) 452-8500 www.eukon.com</p>	<p>DATE ORDER: 11/09</p> <p>INDICATE IF COPIED</p>	<p>03/04/176</p> <p>300 ADDRESSING LORIPAC, CA 94558</p>	<p>SHEET NUMBER</p> <p>A-6</p>
---	---	--	--	---------------------------------------

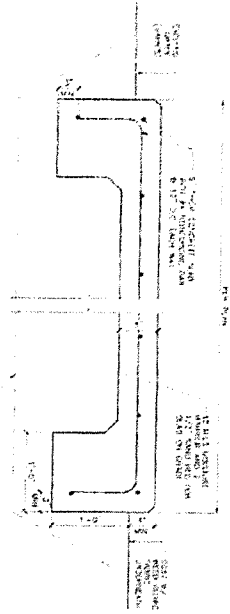

SECTION VIEW

- CONCRETE AND REINFORCING STEEL NOTES:**
1. ALL CONCRETE SHALL BE 4000 PSI COMPRESSIVE STRENGTH AND SHALL BE PLACED AND FINISHED TO THE FINISH SURFACE.
 2. ALL REINFORCING STEEL SHALL BE EPOXY COATED BARS (ASTM A762) WITH A MINIMUM TENSILE STRENGTH OF 60,000 PSI.
 3. ALL REINFORCING STEEL SHALL BE DEVELOPED TO THE FULL TENSILE STRENGTH AND SHALL BE PROTECTED AGAINST CORROSION BY AN EPOXY COATING.
 4. ALL REINFORCING STEEL SHALL BE DEVELOPED TO THE FULL TENSILE STRENGTH AND SHALL BE PROTECTED AGAINST CORROSION BY AN EPOXY COATING.
 5. ALL REINFORCING STEEL SHALL BE DEVELOPED TO THE FULL TENSILE STRENGTH AND SHALL BE PROTECTED AGAINST CORROSION BY AN EPOXY COATING.

CONCRETE PAD

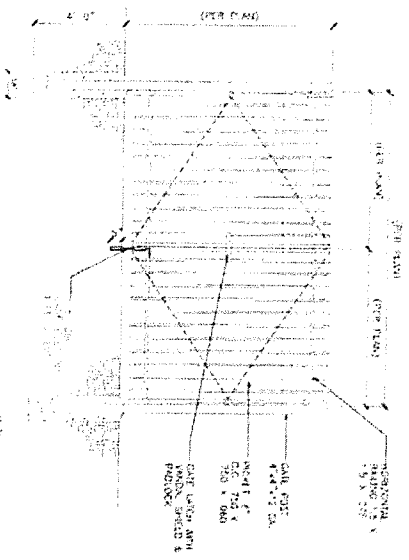

PLAN VIEW

WROUGHT IRON ACCESS GATE

1

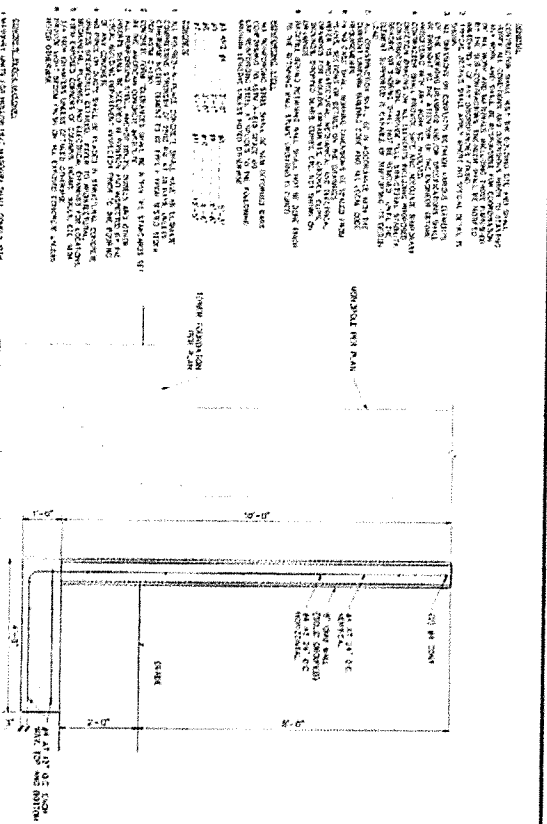

CAST-IN-PLACE CONCRETE WALL

1. ALL CONCRETE SHALL BE 4000 PSI COMPRESSIVE STRENGTH AND SHALL BE PLACED AND FINISHED TO THE FINISH SURFACE.
2. ALL REINFORCING STEEL SHALL BE EPOXY COATED BARS (ASTM A762) WITH A MINIMUM TENSILE STRENGTH OF 60,000 PSI.
3. ALL REINFORCING STEEL SHALL BE DEVELOPED TO THE FULL TENSILE STRENGTH AND SHALL BE PROTECTED AGAINST CORROSION BY AN EPOXY COATING.
4. ALL REINFORCING STEEL SHALL BE DEVELOPED TO THE FULL TENSILE STRENGTH AND SHALL BE PROTECTED AGAINST CORROSION BY AN EPOXY COATING.
5. ALL REINFORCING STEEL SHALL BE DEVELOPED TO THE FULL TENSILE STRENGTH AND SHALL BE PROTECTED AGAINST CORROSION BY AN EPOXY COATING.

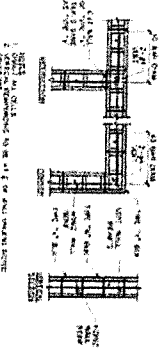

2

CHAU WALL

3

<p>THE NEW at&t</p> <p>1432 GREEN RD, 1ST FLOOR DUNSMUIR, CA 94558</p>	<p>Eukon</p> <p>65 POST STATE 1430 IRVINE, CA 92614 TEL: (949) 552-8866 www.eukon.com</p>	<p>DATE: 01/15/2003</p> <p>PROJECT: CHAU WALL</p> <p>SCALE: 1/4" = 1'-0"</p>	<p>CONSTRUCTION SPECIFICATIONS</p> <p>CHAU WALL</p>	<p>A-8</p>
--	--	--	---	-------------------

LIGHT SPECIFICATION

HALO OUTDOOR

Model	Wattage	Beam Diameter	Beam Spread	Mounting Height
HALO 1000	1000W	1000mm	1000mm	10m
HALO 2000	2000W	2000mm	2000mm	10m
HALO 3000	3000W	3000mm	3000mm	10m



DIE CAST FLOOD BEAMS
selectable
beam spread

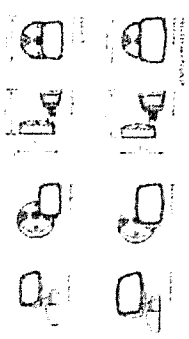

E-1-M

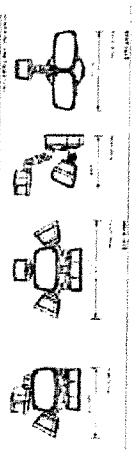

Mounting	Height	Beam Diameter	Beam Spread
Standard	10m	1000mm	1000mm
Adjustable	10m	1000mm	1000mm
Adjustable	10m	1000mm	1000mm
Adjustable	10m	1000mm	1000mm



Area Coverage	Beam Diameter	Beam Spread
1000mm	1000mm	1000mm
2000mm	2000mm	2000mm
3000mm	3000mm	3000mm

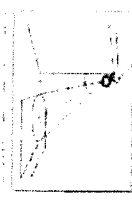

Area Coverage	Beam Diameter	Beam Spread
1000mm	1000mm	1000mm
2000mm	2000mm	2000mm
3000mm	3000mm	3000mm

E-2-M

Model	Wattage	Beam Diameter	Beam Spread	Mounting Height
HALO 1000	1000W	1000mm	1000mm	10m
HALO 2000	2000W	2000mm	2000mm	10m
HALO 3000	3000W	3000mm	3000mm	10m

E-3-M

at&t
1401 SHORE AVE. 4TH FLOOR
DUBLIN, CA 94568

Eukon
65 POSEY AVE. SUITE 1000
IRVINE, CA 92618
TEL: (949) 558-5888

Model	Wattage	Beam Diameter	Beam Spread	Mounting Height
HALO 1000	1000W	1000mm	1000mm	10m
HALO 2000	2000W	2000mm	2000mm	10m
HALO 3000	3000W	3000mm	3000mm	10m

1000
DIE BEAM 1000W
CONVENTIONAL

6504176
300 ALBERT AVE
LOUNGO, CA 94316

EQUIPMENT SPECIFICATIONS

A-9



20 KW DIESEL DC GENERATOR
Part Number: 8220-100-D-20-03-V-125
REQ. 45934



At Home Use
 • 20 KW Diesel DC Generator
 • 20 KW Diesel DC Generator
 • 20 KW Diesel DC Generator
 • 20 KW Diesel DC Generator

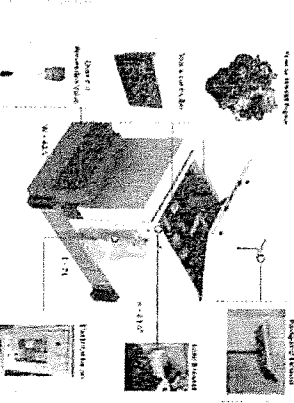
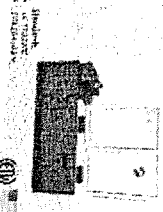

Super cooling
 The generator is equipped with a super cooling system that allows it to operate at a lower temperature than other generators. This results in a longer life span and less maintenance. The super cooling system is a unique feature of the generator and is not found on other generators.

Generator features
 The generator is equipped with a number of features that make it a unique and valuable piece of equipment. These features include a super cooling system, a diesel engine, and a DC generator. The generator is also equipped with a number of safety features that make it a safe and reliable piece of equipment.

SPECIFICATIONS PN: 8220-100-D-20-03-V-125

Engine	Engine cooling system
Engine Type: Diesel Power: 20 KW Fuel: Diesel Cooling: Water Lubrication: Oil Emissions: Low	Engine cooling system Type: Super cooling Capacity: 20 KW Material: Aluminum Finish: Anodized Weight: 100 lbs
Fuel Tank Capacity: 20 Gallons Material: Steel Finish: Painted Weight: 50 lbs	Diesel Fuel system Type: Diesel Capacity: 20 Gallons Material: Steel Finish: Painted Weight: 50 lbs
Power adjustment for conditions Type: Automatic Capacity: 20 KW Material: Aluminum Finish: Anodized Weight: 100 lbs	Diesel Fuel Consumption, Maximum Type: Diesel Capacity: 20 Gallons Material: Steel Finish: Painted Weight: 50 lbs

SOUND TEST RESULTS @ 20KW

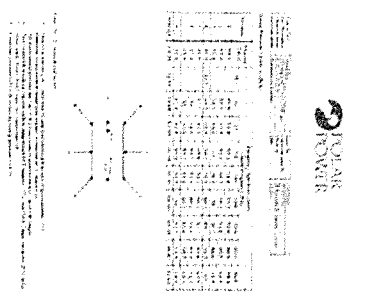

Alternate

Model	8220-100-D-20-03-V-125
Power	20 KW
Weight	100 lbs
Dimensions	24" x 24" x 24"

Starting requirements

Starting method	Manual
Starting voltage	12V
Starting current	100A

Outputs

Output voltage	12V
Output current	100A
Output power	20 KW

Standards

Standard	IEEE 446
Standard	IEEE 447
Standard	IEEE 448

Acoustic Noise Level (dBA)

1m	115
3m	105
10m	95

GENERATOR SPECIFICATION

AT&T

 1451 BAYVIEW AVE., SUITE 100
 OAKLAND, CA 94612

Eukon
 65 POST STREET, SUITE 1000
 RIVERVIEW, CA 94581
 TEL: (949) 513-3565
 WWW.EUKON.COM

GEN-1

GEN-1

GEN-1

GEN-1

GEN-1

8220-100-D-20-03-V-125

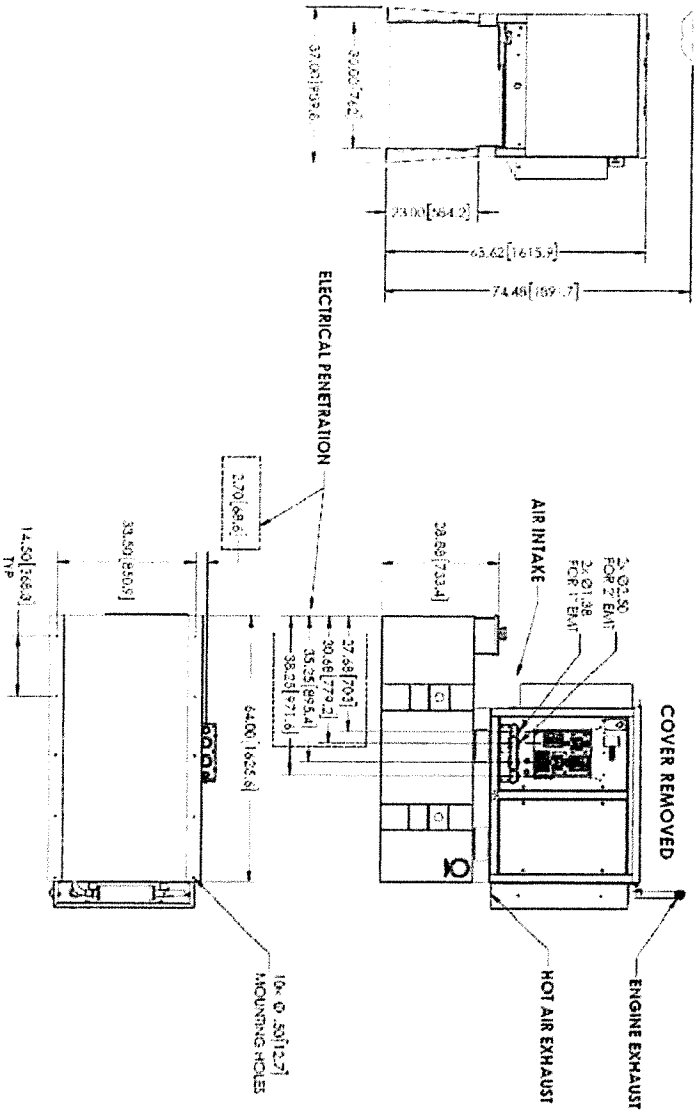

OVERALL DIMENSIONS

125 GALLON TANK (UL142)

POLAR POWER INC.
 2000 W. 14th St.
 Hayward, CA 94541
 (415) 885-1100
 www.polarpower.com

Horizontal Enclosure w/ 125 Gall Double-Walled Tank

SCALE: 1/8" = 1'-0"

SHEET 1 OF 4

GENERATOR SPECIFICATION

at&t
 1401 GARDEN AVENUE
 IRVINE, CA 92614

Eukon
 65 30th STREET, SUITE 1000
 IRVINE, CA 92614
 TEL: (949) 555-5556
 www.eukon.com

NO.	DESCRIPTION	QTY	UNIT
1	GENERATOR ENCLOSURE	1	EA
2	125 GALLON TANK	1	EA
3	10x 1/2" MOUNTING HOLES	10	EA
4	2x 1/2" EMT FOR 1/2" EMT	2	EA
5	2x 1/2" EMT FOR 1/2" EMT	2	EA
6	2x 1/2" EMT FOR 1/2" EMT	2	EA
7	2x 1/2" EMT FOR 1/2" EMT	2	EA
8	2x 1/2" EMT FOR 1/2" EMT	2	EA
9	2x 1/2" EMT FOR 1/2" EMT	2	EA
10	2x 1/2" EMT FOR 1/2" EMT	2	EA
11	2x 1/2" EMT FOR 1/2" EMT	2	EA
12	2x 1/2" EMT FOR 1/2" EMT	2	EA
13	2x 1/2" EMT FOR 1/2" EMT	2	EA
14	2x 1/2" EMT FOR 1/2" EMT	2	EA
15	2x 1/2" EMT FOR 1/2" EMT	2	EA
16	2x 1/2" EMT FOR 1/2" EMT	2	EA
17	2x 1/2" EMT FOR 1/2" EMT	2	EA
18	2x 1/2" EMT FOR 1/2" EMT	2	EA
19	2x 1/2" EMT FOR 1/2" EMT	2	EA
20	2x 1/2" EMT FOR 1/2" EMT	2	EA

GEN-3

300 A. BIRRO AVE.
 LOMPOC, CA 93450

GEN-3

300 A. BIRRO AVE.
 LOMPOC, CA 93450

GEN-3

300 A. BIRRO AVE.
 LOMPOC, CA 93450

SCALE: AS SHOWN
 DATE: 11/11/03
 SHEET NO. B-1

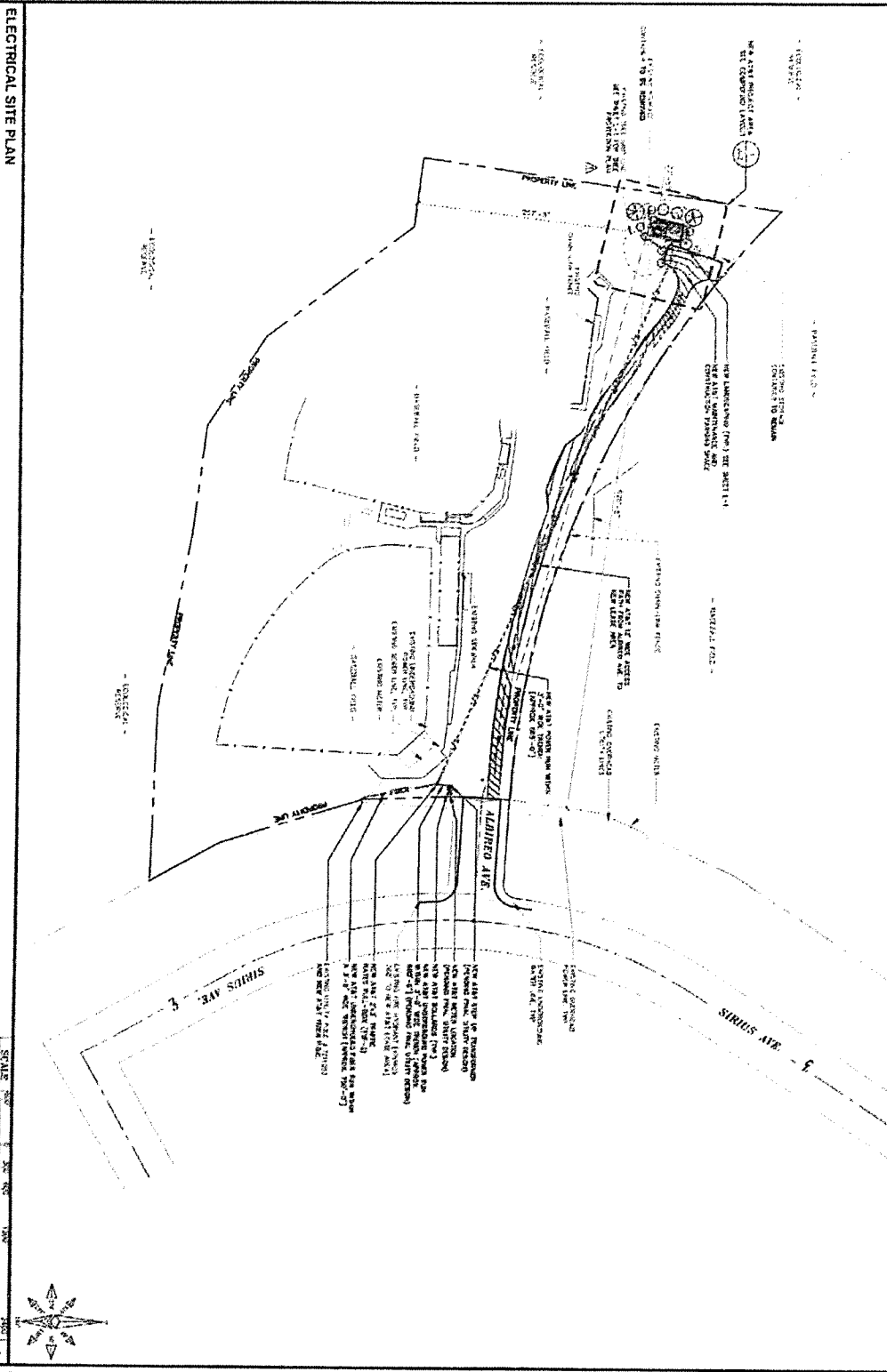

ELECTRICAL SITE PLAN

SCALE: AS SHOWN
 DATE: 11/11/03
 SHEET NO. B-1

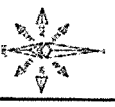

at&t
 THE NEW
 145 15TH ST. 4TH FLOOR
 BAYVIEW, CA 94026

Eukon
 AN IEC COMPANY
 805 POST BLDG 1000
 IRVINE, CA 92618
 TEL: (949) 552-8589
 www.eukon.com

NO.	DESCRIPTION	DATE
1	ISSUED FOR PERMITS	11/11/03
2	REVISED PERMITS	11/11/03
3	REVISED PERMITS	11/11/03
4	REVISED PERMITS	11/11/03
5	REVISED PERMITS	11/11/03
6	REVISED PERMITS	11/11/03
7	REVISED PERMITS	11/11/03
8	REVISED PERMITS	11/11/03
9	REVISED PERMITS	11/11/03
10	REVISED PERMITS	11/11/03

DATE: 11/11/03
 PROJECT: PERMITS

CLIENTS:
 300 ALBRED AVE.
 COMPOC, CA 94136

SHEET TITLE
 ELECTRICAL
 SITE PLAN
 B-1

SINGLE LINEAR PANEL SCHEDULE

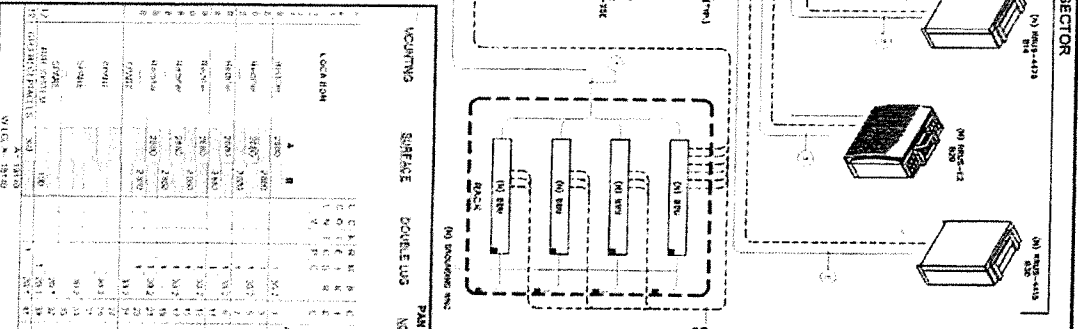
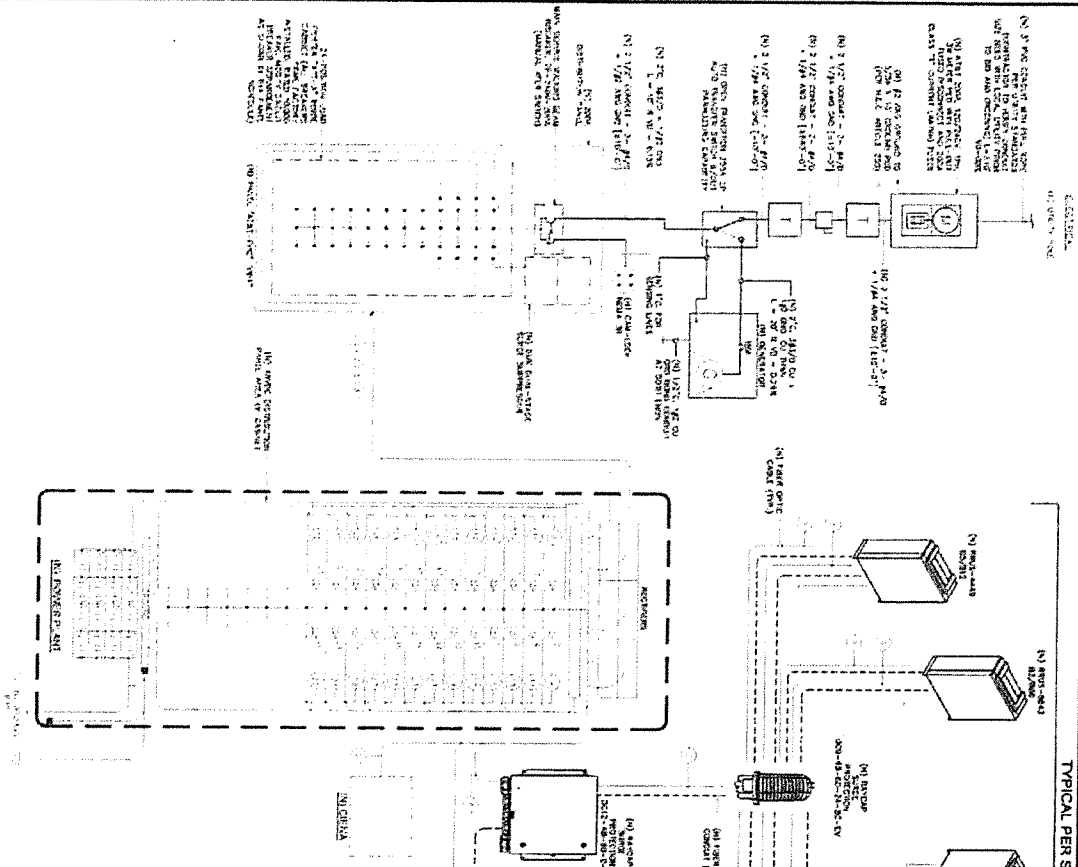

NO.	FLOOR	CIRCUIT SCHEDULE		WIRE SIZE	BULKHEAD
		10	10		
1	10	10	10	10	10
2	10	10	10	10	10
3	10	10	10	10	10
4	10	10	10	10	10
5	10	10	10	10	10
6	10	10	10	10	10
7	10	10	10	10	10
8	10	10	10	10	10
9	10	10	10	10	10
10	10	10	10	10	10

at&t

1425 DOWEN AVE., 2ND. FLOOR
DOWEN, CA 95826

Eukon

65 POST STATE 1000
BRIDGE, CA 94618
TEL: (415) 553-5866

PROJECT

DATE: 11/23/82

PROJECT: 11/23/82

REVISIONS

NO.	DESCRIPTION
1	ISSUED FOR PERMITTING
2	ISSUED FOR PERMITTING
3	ISSUED FOR PERMITTING

DESIGNER

3334174
330 ALBERG AVE
LONDON, CA 94330

DATE: 11/23/82

PROJECT: 11/23/82

PROJECT

DATE: 11/23/82

PROJECT: 11/23/82

REVISIONS

NO.	DESCRIPTION
1	ISSUED FOR PERMITTING
2	ISSUED FOR PERMITTING
3	ISSUED FOR PERMITTING

DESIGNER

3334174
330 ALBERG AVE
LONDON, CA 94330

DATE: 11/23/82

PROJECT: 11/23/82

ELECTRICAL GENERAL NOTES

1. ALL ELECTRICAL WORK SHALL BE IN ACCORDANCE WITH THE LATEST EDITIONS OF THE NATIONAL ELECTRICAL CODE (NEC) AND THE CALIFORNIA ELECTRICAL CODE (CEC).

2. ALL ELECTRICAL WORK SHALL BE INSTALLED IN ACCORDANCE WITH THE MANUFACTURER'S INSTRUCTIONS AND THE LATEST EDITIONS OF THE NATIONAL ELECTRICAL CODE (NEC) AND THE CALIFORNIA ELECTRICAL CODE (CEC).

3. ALL ELECTRICAL WORK SHALL BE INSTALLED IN ACCORDANCE WITH THE LATEST EDITIONS OF THE NATIONAL ELECTRICAL CODE (NEC) AND THE CALIFORNIA ELECTRICAL CODE (CEC).

4. ALL ELECTRICAL WORK SHALL BE INSTALLED IN ACCORDANCE WITH THE LATEST EDITIONS OF THE NATIONAL ELECTRICAL CODE (NEC) AND THE CALIFORNIA ELECTRICAL CODE (CEC).

5. ALL ELECTRICAL WORK SHALL BE INSTALLED IN ACCORDANCE WITH THE LATEST EDITIONS OF THE NATIONAL ELECTRICAL CODE (NEC) AND THE CALIFORNIA ELECTRICAL CODE (CEC).

6. ALL ELECTRICAL WORK SHALL BE INSTALLED IN ACCORDANCE WITH THE LATEST EDITIONS OF THE NATIONAL ELECTRICAL CODE (NEC) AND THE CALIFORNIA ELECTRICAL CODE (CEC).

7. ALL ELECTRICAL WORK SHALL BE INSTALLED IN ACCORDANCE WITH THE LATEST EDITIONS OF THE NATIONAL ELECTRICAL CODE (NEC) AND THE CALIFORNIA ELECTRICAL CODE (CEC).

8. ALL ELECTRICAL WORK SHALL BE INSTALLED IN ACCORDANCE WITH THE LATEST EDITIONS OF THE NATIONAL ELECTRICAL CODE (NEC) AND THE CALIFORNIA ELECTRICAL CODE (CEC).

9. ALL ELECTRICAL WORK SHALL BE INSTALLED IN ACCORDANCE WITH THE LATEST EDITIONS OF THE NATIONAL ELECTRICAL CODE (NEC) AND THE CALIFORNIA ELECTRICAL CODE (CEC).

10. ALL ELECTRICAL WORK SHALL BE INSTALLED IN ACCORDANCE WITH THE LATEST EDITIONS OF THE NATIONAL ELECTRICAL CODE (NEC) AND THE CALIFORNIA ELECTRICAL CODE (CEC).

1. NOT USED

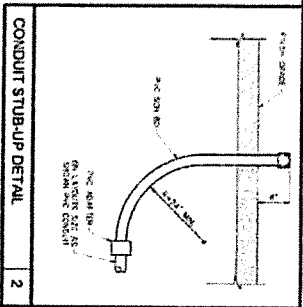

at&t

1425 BROADWAY, 15TH FLOOR
SAN FRANCISCO, CA 94103

Eukon

65 POPE STATE ROAD
SAN FRANCISCO, CA 94103
TEL: 415.555.5555
www.eukon.com

NO.	DESCRIPTION	QTY	UNIT	PRICE	TOTAL
1	CONDUIT				
2	CONDUIT				
3	CONDUIT				
4	CONDUIT				
5	CONDUIT				
6	CONDUIT				
7	CONDUIT				
8	CONDUIT				
9	CONDUIT				
10	CONDUIT				

DATE

PROJECT

DESCRIPTION

320 ALBERO AVE.
LOS ANGELES, CA 90008

ELECTRICAL NOTES & DETAILS

E-3

● ELEVATED STRUCTURE
 ■ METALLIC CONDUIT

LEGEND

NOTES

1. ALL ELECTRICAL WORK SHALL BE IN ACCORDANCE WITH THE NATIONAL ELECTRICAL CODE (NEC) AND ALL APPLICABLE LOCAL ORDINANCES.
2. ALL WIRING SHALL BE IN ACCORDANCE WITH THE NATIONAL FIRE ALARM AND SIGNAL ASSOCIATION (NFPA) 70-95.
3. ALL ELECTRICAL WORK SHALL BE IN ACCORDANCE WITH THE NATIONAL FIRE ALARM AND SIGNAL ASSOCIATION (NFPA) 70-95.
4. ALL ELECTRICAL WORK SHALL BE IN ACCORDANCE WITH THE NATIONAL FIRE ALARM AND SIGNAL ASSOCIATION (NFPA) 70-95.
5. ALL ELECTRICAL WORK SHALL BE IN ACCORDANCE WITH THE NATIONAL FIRE ALARM AND SIGNAL ASSOCIATION (NFPA) 70-95.
6. ALL ELECTRICAL WORK SHALL BE IN ACCORDANCE WITH THE NATIONAL FIRE ALARM AND SIGNAL ASSOCIATION (NFPA) 70-95.
7. ALL ELECTRICAL WORK SHALL BE IN ACCORDANCE WITH THE NATIONAL FIRE ALARM AND SIGNAL ASSOCIATION (NFPA) 70-95.
8. ALL ELECTRICAL WORK SHALL BE IN ACCORDANCE WITH THE NATIONAL FIRE ALARM AND SIGNAL ASSOCIATION (NFPA) 70-95.
9. ALL ELECTRICAL WORK SHALL BE IN ACCORDANCE WITH THE NATIONAL FIRE ALARM AND SIGNAL ASSOCIATION (NFPA) 70-95.
10. ALL ELECTRICAL WORK SHALL BE IN ACCORDANCE WITH THE NATIONAL FIRE ALARM AND SIGNAL ASSOCIATION (NFPA) 70-95.

GROUNDING ANTENNA ONE-LINE

GROUNDING ANTENNA ONE-LINE

1

2

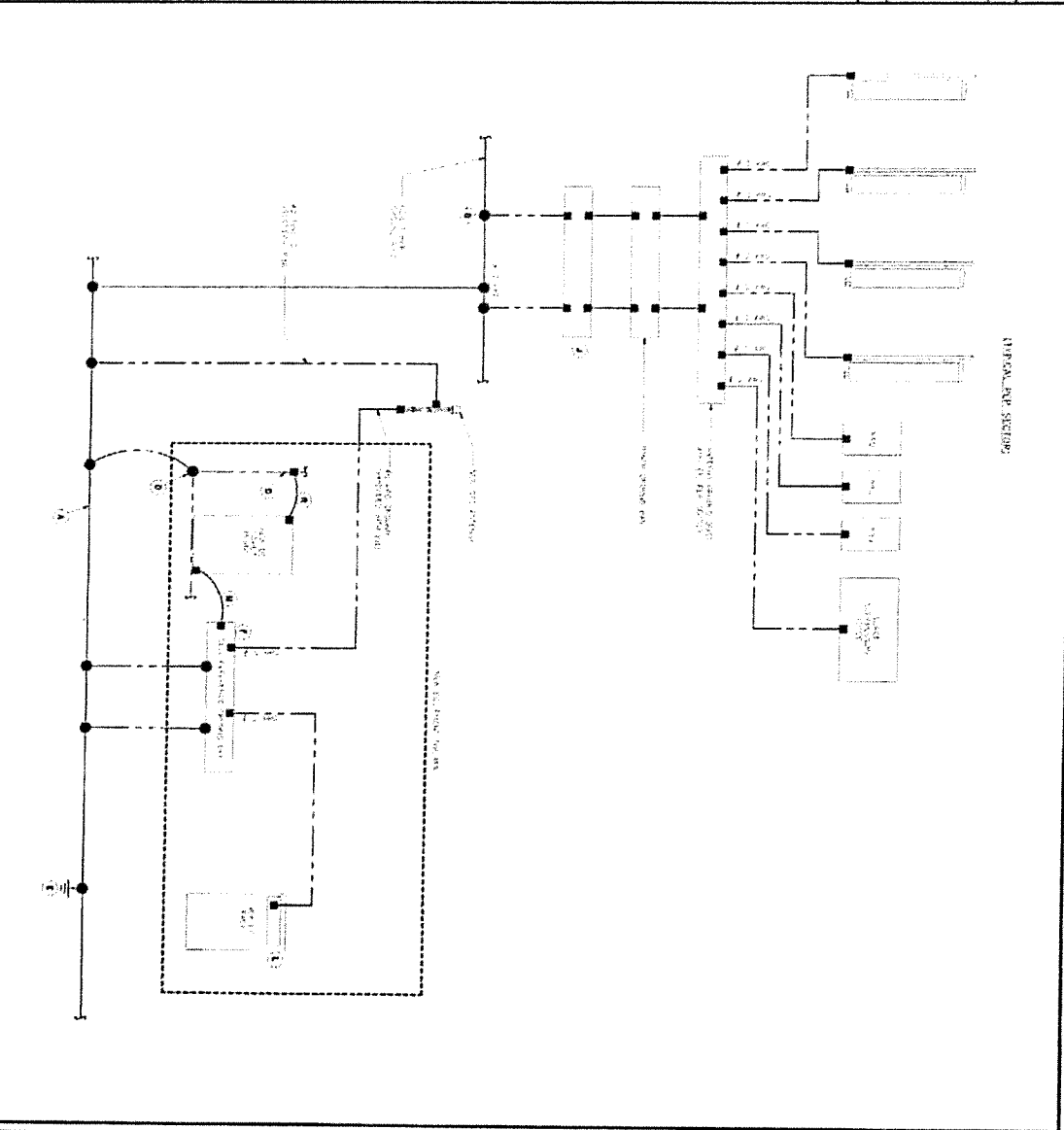

AT&T

The new **at&t**

1405 EMBURY AVE. 12TH FLOOR
 IRVINE, CA 92714

EUKON

Eukon

an AT&T Communications, Inc. Company
 65 POFF, SUITE 1000
 RYMO, CA 92618
 TEL (949) 553-8800
 www.eukon.com

REVISIONS

NO.	DESCRIPTION	DATE

DATE ISSUED: 11/28/93

PROJECT: 100000000000

CS104176
 300 ALBERO AVE.
 LOMPOC, CA 93356

WALT TITEL
 EQUIPMENT GROUNDING
 PLAN

10/1/93

G-1

CONSTRUCTION

CONDUCTED BY THE DEVELOPER:

- CONDUCTED BY THE DEVELOPER
- CONDUCTED BY THE DEVELOPER
- CONDUCTED BY THE DEVELOPER

FOR THE PURPOSES OF THE CONSTRUCTION OF THE ANTENNA AND EQUIPMENT GROUNDING SYSTEM, THE DEVELOPER HAS HAD THE FOLLOWING SYSTEMS AND EQUIPMENT INSTALLED:

ANTENNA AND EQUIPMENT GROUNDING SYSTEM

CONDUCTED BY THE DEVELOPER

FOR THE PURPOSES OF THE CONSTRUCTION OF THE ANTENNA AND EQUIPMENT GROUNDING SYSTEM, THE DEVELOPER HAS HAD THE FOLLOWING SYSTEMS AND EQUIPMENT INSTALLED:

ANTENNA AND EQUIPMENT GROUNDING SYSTEM

CONDUCTED BY THE DEVELOPER

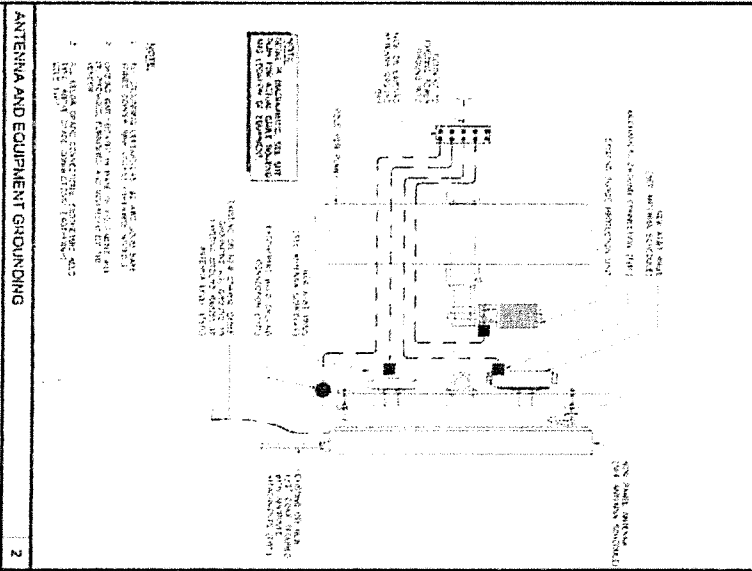

ANTENNA AND EQUIPMENT GROUNDING

2

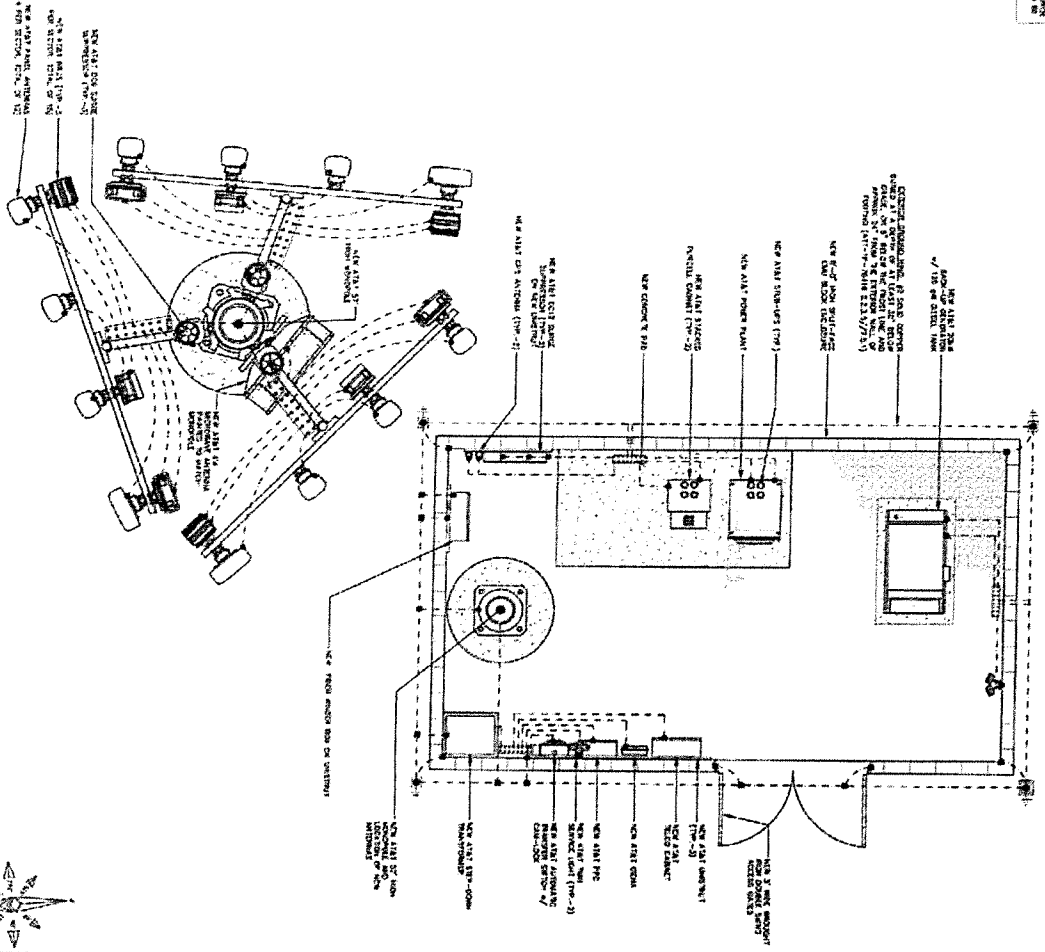

AT&T

1431 Elgin Rd., Box 1000
 San Jose, CA 95128

Eukon

AN ETE COMPANY, INC. COMPANY

65 POST SUITE 1000
 IRVINE, CA 92618
 TEL: (714) 222-2828
 www.eukon.com

NO.	DESCRIPTION	DATE
1	REVISION	
2	REVISION	
3	REVISION	
4	REVISION	
5	REVISION	
6	REVISION	
7	REVISION	
8	REVISION	
9	REVISION	
10	REVISION	

OUTRIGGER PLANS

PROFESSIONAL SEAL

CS02178
 100 ALBERO AVE.
 COVINGTON, CA 95318

EQUIPMENT GROUNDING PLAN

SCALE 1/8\"/>

G-2

<p>NOTE: 1. DO NOT REMOVE GROUNDING OF ANTENNA FROM ANTENNA CABLE. 2. GROUNDING OF ANTENNA CABLE MUST BE MAINTAINED AT ALL TIMES. 3. ANTENNA CABLE MUST BE GROUNDED TO THE SAME GROUND BAR AS THE ANTENNA. 4. ANTENNA CABLE MUST BE GROUNDED TO THE SAME GROUND BAR AS THE ANTENNA.</p>	<p>NOTE: 1. GROUND WIRE MUST BE INSTALLED TO THE SAME GROUND BAR AS THE ANTENNA. 2. GROUND WIRE MUST BE INSTALLED TO THE SAME GROUND BAR AS THE ANTENNA.</p>	<p>NOTE: 1. GROUND BAR MUST BE INSTALLED TO THE SAME GROUND BAR AS THE ANTENNA. 2. GROUND BAR MUST BE INSTALLED TO THE SAME GROUND BAR AS THE ANTENNA.</p>	<p>NOTE: 1. GROUND WIRE MUST BE INSTALLED TO THE SAME GROUND BAR AS THE ANTENNA. 2. GROUND WIRE MUST BE INSTALLED TO THE SAME GROUND BAR AS THE ANTENNA.</p>
<p>NOTE: 1. EXOTHERMIC WELD CONNECTION MUST BE USED FOR ALL GROUNDING CONNECTIONS. 2. EXOTHERMIC WELD CONNECTION MUST BE USED FOR ALL GROUNDING CONNECTIONS.</p>	<p>NOTE: 1. MECHANICAL CONNECTION MUST BE USED FOR ALL GROUNDING CONNECTIONS. 2. MECHANICAL CONNECTION MUST BE USED FOR ALL GROUNDING CONNECTIONS.</p>	<p>NOTE: 1. GPS ANTENNA MUST BE GROUNDED TO THE SAME GROUND BAR AS THE ANTENNA. 2. GPS ANTENNA MUST BE GROUNDED TO THE SAME GROUND BAR AS THE ANTENNA.</p>	<p>NOTE: 1. GROUNDING NOTES MUST BE USED FOR ALL GROUNDING CONNECTIONS. 2. GROUNDING NOTES MUST BE USED FOR ALL GROUNDING CONNECTIONS.</p>
<p>NOTE: 1. HATCHPLATE GROUNDING AT SHELTER MUST BE USED FOR ALL GROUNDING CONNECTIONS. 2. HATCHPLATE GROUNDING AT SHELTER MUST BE USED FOR ALL GROUNDING CONNECTIONS.</p>	<p>NOT USED</p>	<p>NOT USED</p>	<p>NOT USED</p>

<p>1425 BAYVIEW BLVD SAN JOSE, CA 95128</p>	<p>05 POST SATE 1000 RYNEX, CA 92519 TEL: (909) 553-8599 WWW.EUKON.COM</p>	<p>REVISIONS</p> <table border="1"> <tr> <th>NO.</th> <th>DATE</th> <th>DESCRIPTION</th> </tr> <tr> <td>1</td> <td>01/01/00</td> <td>ISSUED FOR CONSTRUCTION</td> </tr> <tr> <td>2</td> <td>01/01/00</td> <td>ISSUED FOR CONSTRUCTION</td> </tr> <tr> <td>3</td> <td>01/01/00</td> <td>ISSUED FOR CONSTRUCTION</td> </tr> </table>	NO.	DATE	DESCRIPTION	1	01/01/00	ISSUED FOR CONSTRUCTION	2	01/01/00	ISSUED FOR CONSTRUCTION	3	01/01/00	ISSUED FOR CONSTRUCTION	<p>DATE: 01/01/00 PROJECT: 01/01/00</p>	<p>500 ALBERO AVE. LOMPOC, CA 93436</p>	<p>GROUNDING DETAILS</p>	<p>G-3</p>
NO.	DATE	DESCRIPTION																
1	01/01/00	ISSUED FOR CONSTRUCTION																
2	01/01/00	ISSUED FOR CONSTRUCTION																
3	01/01/00	ISSUED FOR CONSTRUCTION																

	<p>NOT USED</p>	

<p>1455 CENTRE # 100, 3RD FLOOR IRVINE, CA 92714</p>	<p>65 GOLF SLOTT ROAD IRVINE, CA 92618 TEL: (949) 555-8466 www.eukon.com</p>	<p>DATE: 08/01/11/08 PROJECT: GROUNDING</p> <p>DESIGNED BY: [Signature] CHECKED BY: [Signature]</p>	<p>03/01/17/06 1000 AMERICO AVE LOS ANGELES, CA 90016</p>	<p>GROUNDING DETAILS</p> <p>ARTIST NUMBER: G-5</p>
--	--	---	---	--

GS **PYL12V18SFT**
12V 185Ah-FH

1. This battery is designed for use in...
 2. The recommended charger...
 3. Do not use...
 4. Do not...
 5. Do not...
 6. Do not...
 7. Do not...
 8. Do not...
 9. Do not...
 10. Do not...

PYL12V18SFT 12V 185Ah-FH

1. This battery is designed for use in...
 2. The recommended charger...
 3. Do not use...
 4. Do not...
 5. Do not...
 6. Do not...
 7. Do not...
 8. Do not...
 9. Do not...
 10. Do not...

DATE	DESCRIPTION	BY	CHKD	APP'D

ERC REPAIRMENT NOTES

1. The battery was found to be...
 2. The electrolyte level was...
 3. The terminals were...
 4. The battery was...
 5. The battery was...
 6. The battery was...
 7. The battery was...
 8. The battery was...
 9. The battery was...
 10. The battery was...

NOTES

1. The battery was found to be...
 2. The electrolyte level was...
 3. The terminals were...
 4. The battery was...
 5. The battery was...
 6. The battery was...
 7. The battery was...
 8. The battery was...
 9. The battery was...
 10. The battery was...

at&t
1442 DUNDON AVE., 3RD FLOOR
IRVINE, CA 92714

Eukon
65 HOGUE STATE ROAD
TEL: (949) 559-1996
www.eukonbattery.com

DATE	DESCRIPTION	BY	CHKD	APP'D

DATE/SIGNATURE

DATE/SIGNATURE
 309 ALBERDO AVE
 COMPOD, CA 94586

BATTERY INFORMATION

FD-1

1. ALL PLANTING SHALL BE INSTALLED IN ACCORDANCE WITH THE CITY OF SAN JOSE PLANTING SPECIFICATIONS AND THE CALIFORNIA PLANTING SPECIFICATIONS. 2. PLANTING SHALL BE INSTALLED IN ACCORDANCE WITH THE CITY OF SAN JOSE PLANTING SPECIFICATIONS AND THE CALIFORNIA PLANTING SPECIFICATIONS.

PLANTING SPECIFICATIONS
 1. ALL PLANTING SHALL BE INSTALLED IN ACCORDANCE WITH THE CITY OF SAN JOSE PLANTING SPECIFICATIONS AND THE CALIFORNIA PLANTING SPECIFICATIONS.
 2. PLANTING SHALL BE INSTALLED IN ACCORDANCE WITH THE CITY OF SAN JOSE PLANTING SPECIFICATIONS AND THE CALIFORNIA PLANTING SPECIFICATIONS.

SYMBOLS
 1. PLANTING SPECIFICATIONS
 2. PLANTING SPECIFICATIONS
 3. PLANTING SPECIFICATIONS
 4. PLANTING SPECIFICATIONS
 5. PLANTING SPECIFICATIONS
 6. PLANTING SPECIFICATIONS
 7. PLANTING SPECIFICATIONS
 8. PLANTING SPECIFICATIONS
 9. PLANTING SPECIFICATIONS
 10. PLANTING SPECIFICATIONS

PLANTING SPECIFICATIONS
 1. ALL PLANTING SHALL BE INSTALLED IN ACCORDANCE WITH THE CITY OF SAN JOSE PLANTING SPECIFICATIONS AND THE CALIFORNIA PLANTING SPECIFICATIONS.
 2. PLANTING SHALL BE INSTALLED IN ACCORDANCE WITH THE CITY OF SAN JOSE PLANTING SPECIFICATIONS AND THE CALIFORNIA PLANTING SPECIFICATIONS.
 3. PLANTING SHALL BE INSTALLED IN ACCORDANCE WITH THE CITY OF SAN JOSE PLANTING SPECIFICATIONS AND THE CALIFORNIA PLANTING SPECIFICATIONS.
 4. PLANTING SHALL BE INSTALLED IN ACCORDANCE WITH THE CITY OF SAN JOSE PLANTING SPECIFICATIONS AND THE CALIFORNIA PLANTING SPECIFICATIONS.
 5. PLANTING SHALL BE INSTALLED IN ACCORDANCE WITH THE CITY OF SAN JOSE PLANTING SPECIFICATIONS AND THE CALIFORNIA PLANTING SPECIFICATIONS.
 6. PLANTING SHALL BE INSTALLED IN ACCORDANCE WITH THE CITY OF SAN JOSE PLANTING SPECIFICATIONS AND THE CALIFORNIA PLANTING SPECIFICATIONS.
 7. PLANTING SHALL BE INSTALLED IN ACCORDANCE WITH THE CITY OF SAN JOSE PLANTING SPECIFICATIONS AND THE CALIFORNIA PLANTING SPECIFICATIONS.
 8. PLANTING SHALL BE INSTALLED IN ACCORDANCE WITH THE CITY OF SAN JOSE PLANTING SPECIFICATIONS AND THE CALIFORNIA PLANTING SPECIFICATIONS.
 9. PLANTING SHALL BE INSTALLED IN ACCORDANCE WITH THE CITY OF SAN JOSE PLANTING SPECIFICATIONS AND THE CALIFORNIA PLANTING SPECIFICATIONS.
 10. PLANTING SHALL BE INSTALLED IN ACCORDANCE WITH THE CITY OF SAN JOSE PLANTING SPECIFICATIONS AND THE CALIFORNIA PLANTING SPECIFICATIONS.

SITE PLAN

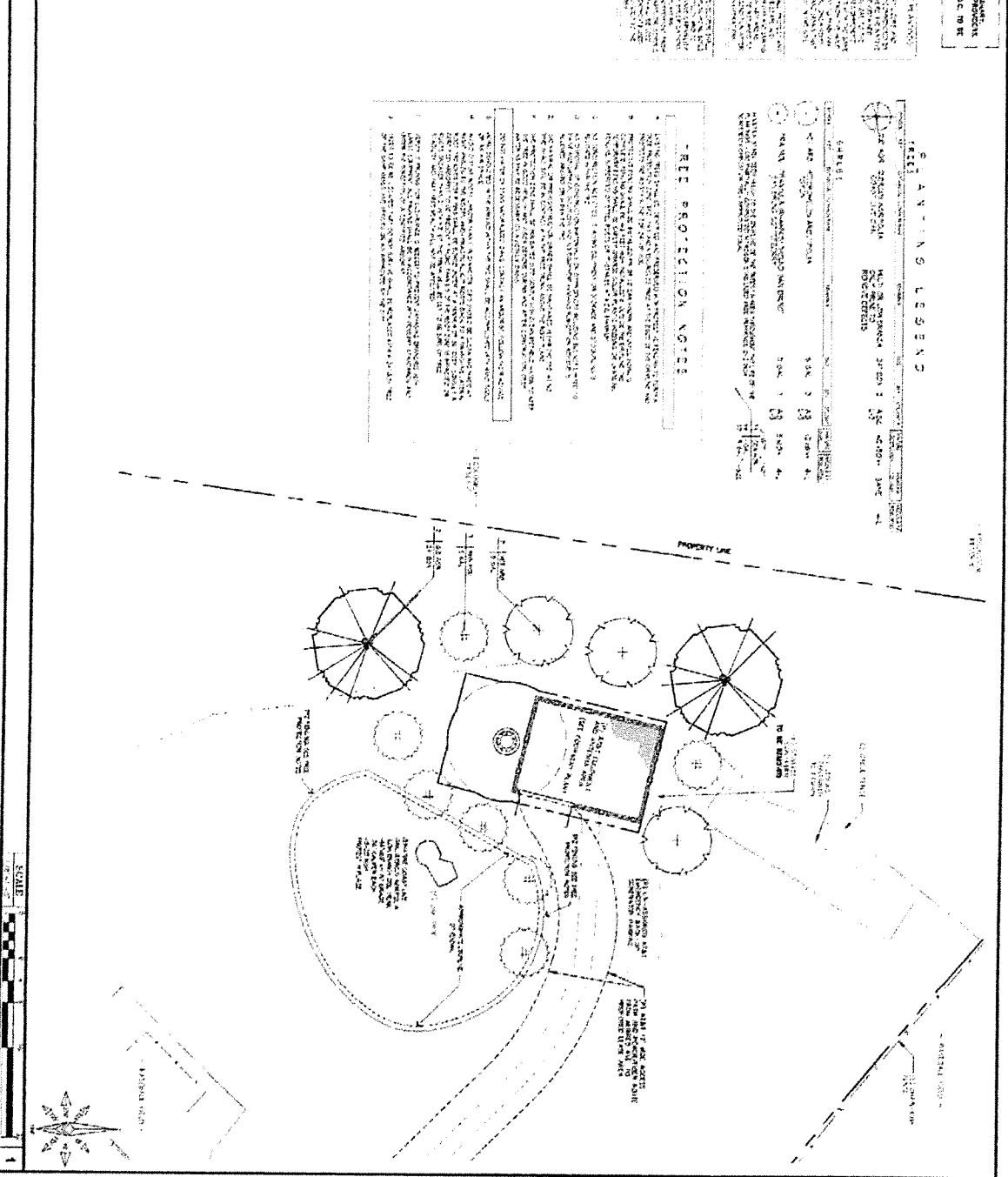

PROJECT
 at&t
 445 CENTER AVE., 3RD FLOOR
 SAN JOSE, CA 95128

DESIGNER
 M Eukon
 64 POINT SAN LEONARD
 RIVER, CA 94515
 TEL: (415) 551-8065
 www.mekon.com

NO.	DESCRIPTION	DATE
1	PRELIMINARY	10/10/00
2	REVISED	10/10/00
3	REVISED	10/10/00
4	REVISED	10/10/00
5	REVISED	10/10/00
6	REVISED	10/10/00
7	REVISED	10/10/00
8	REVISED	10/10/00
9	REVISED	10/10/00
10	REVISED	10/10/00

DMIA
 1000 Market Street, Suite 1000
 San Francisco, CA 94102
 (415) 774-2000

PROJECT INFORMATION
 CS04176
 200 ALBERO AVE.
 LINDSAY, CA 94336

PLANTING PLAN
 EAST TOWERS

1-1

SITE PLAN

GENERAL IRRIGATION NOTES

1. ALL IRRIGATION SYSTEMS SHALL BE DESIGNED TO PROVIDE UNIFORM WATER DISTRIBUTION TO ALL PLANTING AREAS.
2. THE IRRIGATION SYSTEM SHALL BE DESIGNED TO OPERATE AT A PRESSURE OF 150 PSI.
3. ALL IRRIGATION SYSTEMS SHALL BE DESIGNED TO OPERATE AT A FLOW RATE OF 10 GPM PER LINEAL FOOT.
4. ALL IRRIGATION SYSTEMS SHALL BE DESIGNED TO OPERATE AT A SCHEDULING RATE OF 1.0 INCH PER WEEK.
5. ALL IRRIGATION SYSTEMS SHALL BE DESIGNED TO OPERATE AT A SCHEDULING RATE OF 1.0 INCH PER WEEK.
6. ALL IRRIGATION SYSTEMS SHALL BE DESIGNED TO OPERATE AT A SCHEDULING RATE OF 1.0 INCH PER WEEK.
7. ALL IRRIGATION SYSTEMS SHALL BE DESIGNED TO OPERATE AT A SCHEDULING RATE OF 1.0 INCH PER WEEK.
8. ALL IRRIGATION SYSTEMS SHALL BE DESIGNED TO OPERATE AT A SCHEDULING RATE OF 1.0 INCH PER WEEK.
9. ALL IRRIGATION SYSTEMS SHALL BE DESIGNED TO OPERATE AT A SCHEDULING RATE OF 1.0 INCH PER WEEK.
10. ALL IRRIGATION SYSTEMS SHALL BE DESIGNED TO OPERATE AT A SCHEDULING RATE OF 1.0 INCH PER WEEK.

EXISTING IRRIGATION SYSTEMS

THE EXISTING IRRIGATION SYSTEMS SHALL BE MAINTAINED AND OPERATED AS SHOWN ON THE ATTACHED DRAWINGS. ANY CHANGES TO THE EXISTING SYSTEMS SHALL BE APPROVED BY THE ENGINEER.

IRRIGATION LEGEND

SYMBOL	DESCRIPTION
(Symbol)	1. IRRIGATION SYSTEM
(Symbol)	2. IRRIGATION SYSTEM
(Symbol)	3. IRRIGATION SYSTEM
(Symbol)	4. IRRIGATION SYSTEM
(Symbol)	5. IRRIGATION SYSTEM
(Symbol)	6. IRRIGATION SYSTEM
(Symbol)	7. IRRIGATION SYSTEM
(Symbol)	8. IRRIGATION SYSTEM
(Symbol)	9. IRRIGATION SYSTEM
(Symbol)	10. IRRIGATION SYSTEM
(Symbol)	11. IRRIGATION SYSTEM
(Symbol)	12. IRRIGATION SYSTEM
(Symbol)	13. IRRIGATION SYSTEM
(Symbol)	14. IRRIGATION SYSTEM
(Symbol)	15. IRRIGATION SYSTEM
(Symbol)	16. IRRIGATION SYSTEM
(Symbol)	17. IRRIGATION SYSTEM
(Symbol)	18. IRRIGATION SYSTEM
(Symbol)	19. IRRIGATION SYSTEM
(Symbol)	20. IRRIGATION SYSTEM
(Symbol)	21. IRRIGATION SYSTEM
(Symbol)	22. IRRIGATION SYSTEM
(Symbol)	23. IRRIGATION SYSTEM
(Symbol)	24. IRRIGATION SYSTEM
(Symbol)	25. IRRIGATION SYSTEM
(Symbol)	26. IRRIGATION SYSTEM
(Symbol)	27. IRRIGATION SYSTEM
(Symbol)	28. IRRIGATION SYSTEM
(Symbol)	29. IRRIGATION SYSTEM
(Symbol)	30. IRRIGATION SYSTEM
(Symbol)	31. IRRIGATION SYSTEM
(Symbol)	32. IRRIGATION SYSTEM
(Symbol)	33. IRRIGATION SYSTEM
(Symbol)	34. IRRIGATION SYSTEM
(Symbol)	35. IRRIGATION SYSTEM
(Symbol)	36. IRRIGATION SYSTEM
(Symbol)	37. IRRIGATION SYSTEM
(Symbol)	38. IRRIGATION SYSTEM
(Symbol)	39. IRRIGATION SYSTEM
(Symbol)	40. IRRIGATION SYSTEM
(Symbol)	41. IRRIGATION SYSTEM
(Symbol)	42. IRRIGATION SYSTEM
(Symbol)	43. IRRIGATION SYSTEM
(Symbol)	44. IRRIGATION SYSTEM
(Symbol)	45. IRRIGATION SYSTEM
(Symbol)	46. IRRIGATION SYSTEM
(Symbol)	47. IRRIGATION SYSTEM
(Symbol)	48. IRRIGATION SYSTEM
(Symbol)	49. IRRIGATION SYSTEM
(Symbol)	50. IRRIGATION SYSTEM
(Symbol)	51. IRRIGATION SYSTEM
(Symbol)	52. IRRIGATION SYSTEM
(Symbol)	53. IRRIGATION SYSTEM
(Symbol)	54. IRRIGATION SYSTEM
(Symbol)	55. IRRIGATION SYSTEM
(Symbol)	56. IRRIGATION SYSTEM
(Symbol)	57. IRRIGATION SYSTEM
(Symbol)	58. IRRIGATION SYSTEM
(Symbol)	59. IRRIGATION SYSTEM
(Symbol)	60. IRRIGATION SYSTEM
(Symbol)	61. IRRIGATION SYSTEM
(Symbol)	62. IRRIGATION SYSTEM
(Symbol)	63. IRRIGATION SYSTEM
(Symbol)	64. IRRIGATION SYSTEM
(Symbol)	65. IRRIGATION SYSTEM
(Symbol)	66. IRRIGATION SYSTEM
(Symbol)	67. IRRIGATION SYSTEM
(Symbol)	68. IRRIGATION SYSTEM
(Symbol)	69. IRRIGATION SYSTEM
(Symbol)	70. IRRIGATION SYSTEM
(Symbol)	71. IRRIGATION SYSTEM
(Symbol)	72. IRRIGATION SYSTEM
(Symbol)	73. IRRIGATION SYSTEM
(Symbol)	74. IRRIGATION SYSTEM
(Symbol)	75. IRRIGATION SYSTEM
(Symbol)	76. IRRIGATION SYSTEM
(Symbol)	77. IRRIGATION SYSTEM
(Symbol)	78. IRRIGATION SYSTEM
(Symbol)	79. IRRIGATION SYSTEM
(Symbol)	80. IRRIGATION SYSTEM
(Symbol)	81. IRRIGATION SYSTEM
(Symbol)	82. IRRIGATION SYSTEM
(Symbol)	83. IRRIGATION SYSTEM
(Symbol)	84. IRRIGATION SYSTEM
(Symbol)	85. IRRIGATION SYSTEM
(Symbol)	86. IRRIGATION SYSTEM
(Symbol)	87. IRRIGATION SYSTEM
(Symbol)	88. IRRIGATION SYSTEM
(Symbol)	89. IRRIGATION SYSTEM
(Symbol)	90. IRRIGATION SYSTEM
(Symbol)	91. IRRIGATION SYSTEM
(Symbol)	92. IRRIGATION SYSTEM
(Symbol)	93. IRRIGATION SYSTEM
(Symbol)	94. IRRIGATION SYSTEM
(Symbol)	95. IRRIGATION SYSTEM
(Symbol)	96. IRRIGATION SYSTEM
(Symbol)	97. IRRIGATION SYSTEM
(Symbol)	98. IRRIGATION SYSTEM
(Symbol)	99. IRRIGATION SYSTEM
(Symbol)	100. IRRIGATION SYSTEM

PLAN OF CONNECTION AND CONTROLLER INSTALLATION

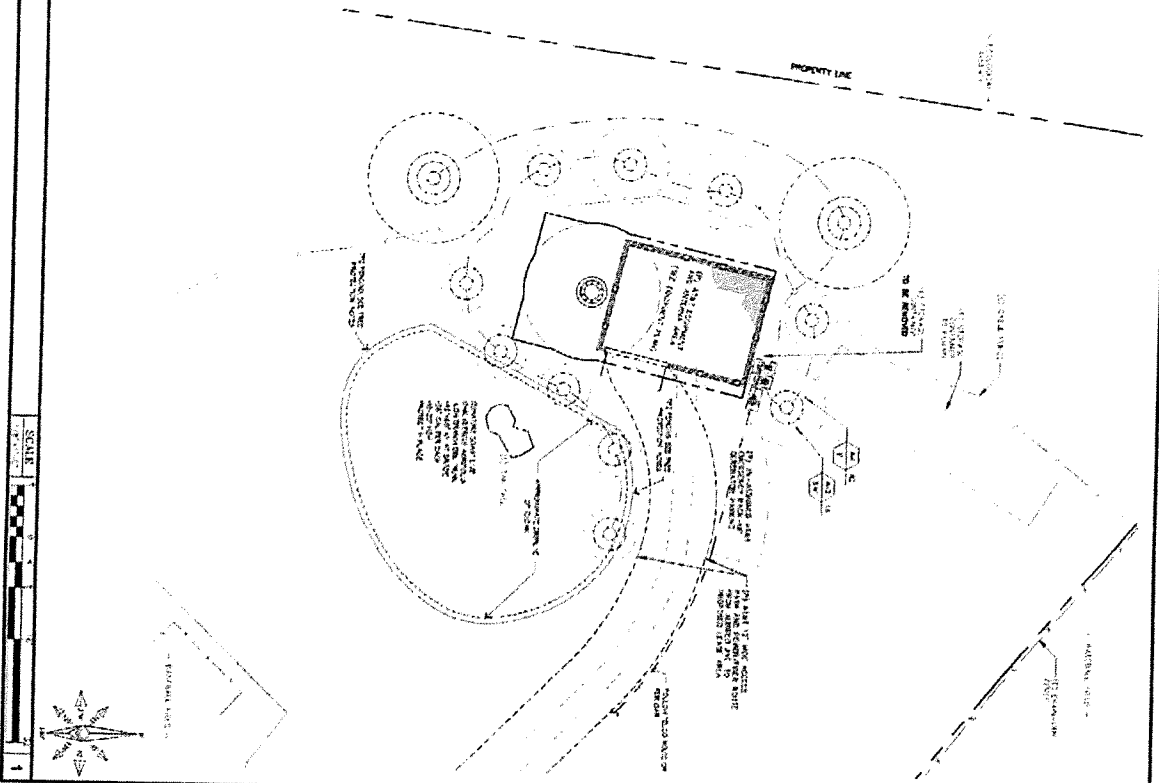

<p>PROJECT INFORMATION</p> <p>CS13178 300 ALHAMBRA AVE LIVERMORE, CA 94550</p>	<p>PROJECT INFORMATION</p> <p>CS13178 300 ALHAMBRA AVE LIVERMORE, CA 94550</p>	<p>DMIA</p> <p>DIAGNOSTIC MEASUREMENTS & IRRIGATION ANALYSIS</p> <p>3000 MAINTENANCE DR. SUITE 100 LIVERMORE, CA 94550</p>	<p>Eukon</p> <p>65 POOT SLURP TUB IRVINE, CA 92618 TEL: (949) 553-5999</p>	<p>at&t</p> <p>455 GARDNER AVE. 3RD FLOOR FREMONT, CA 94538</p>	<p>SCALE</p> <p>1" = 1'</p>	<p>IRRIGATION PLAN</p> <p>L-2</p>
---	---	---	---	--	------------------------------------	--

EXHIBIT D

GAMMA SECTOR		DELTA SECTOR		ALPHA SECTOR	
Channel	Power	Channel	Power	Channel	Power
1	10	1	10	1	10
2	10	2	10	2	10
3	10	3	10	3	10
4	10	4	10	4	10
5	10	5	10	5	10
6	10	6	10	6	10
7	10	7	10	7	10
8	10	8	10	8	10
9	10	9	10	9	10
10	10	10	10	10	10
11	10	11	10	11	10
12	10	12	10	12	10
13	10	13	10	13	10
14	10	14	10	14	10
15	10	15	10	15	10
16	10	16	10	16	10
17	10	17	10	17	10
18	10	18	10	18	10
19	10	19	10	19	10
20	10	20	10	20	10
21	10	21	10	21	10
22	10	22	10	22	10
23	10	23	10	23	10
24	10	24	10	24	10
25	10	25	10	25	10
26	10	26	10	26	10
27	10	27	10	27	10
28	10	28	10	28	10
29	10	29	10	29	10
30	10	30	10	30	10

NOTES, IN CONTRACTS

NEW ANTENNA AND RU SCHEDULE

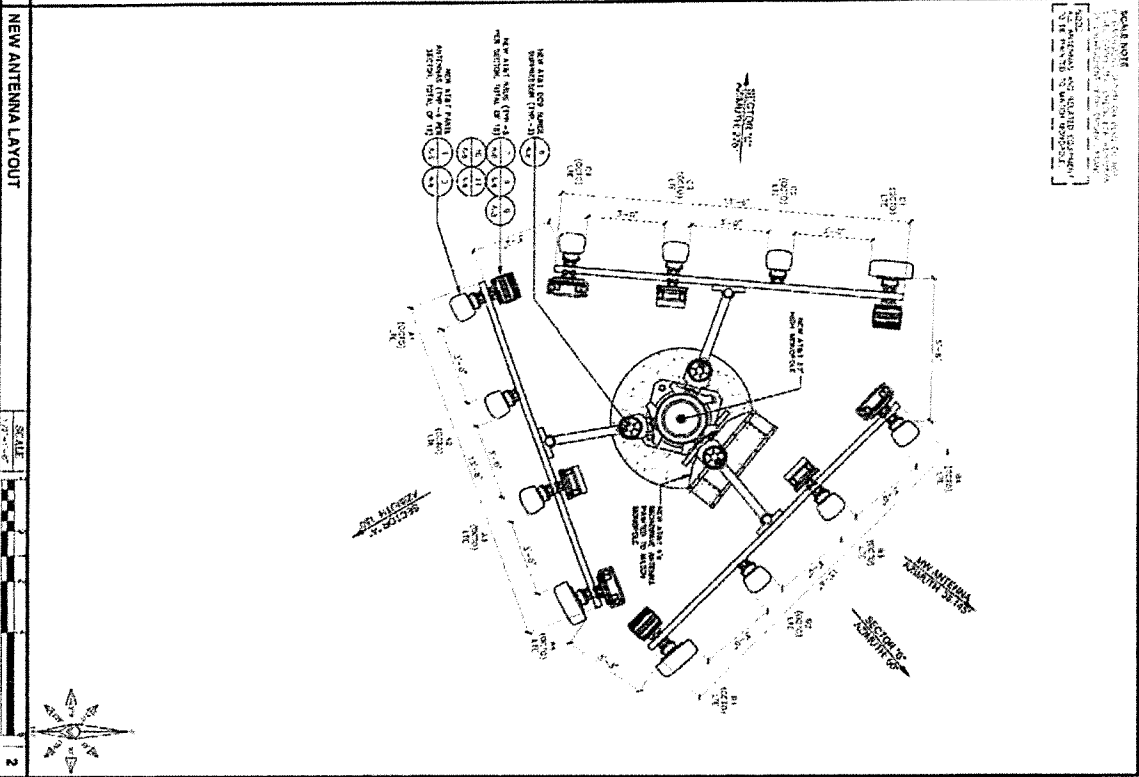

2025/04/01

at&t
 THE BELL COMPANY
 1425 GARDEN AVENUE, 1000
 RAYNOR, VA 22090

Eukon
 65 POST SITE ROAD
 RAYNOR, VA 22091
 TEL: (703) 535-8526
www.eukon.com

DATE 04/01/2025
TIME 10:00 AM
PROJECT NEW ANTENNA LAYOUT

REVISIONS

NO.	DESCRIPTION	DATE
1	ISSUE FOR PERMITTING	04/01/2025
2	ISSUE FOR PERMITTING	04/01/2025
3	ISSUE FOR PERMITTING	04/01/2025
4	ISSUE FOR PERMITTING	04/01/2025
5	ISSUE FOR PERMITTING	04/01/2025
6	ISSUE FOR PERMITTING	04/01/2025
7	ISSUE FOR PERMITTING	04/01/2025
8	ISSUE FOR PERMITTING	04/01/2025
9	ISSUE FOR PERMITTING	04/01/2025
10	ISSUE FOR PERMITTING	04/01/2025
11	ISSUE FOR PERMITTING	04/01/2025
12	ISSUE FOR PERMITTING	04/01/2025
13	ISSUE FOR PERMITTING	04/01/2025
14	ISSUE FOR PERMITTING	04/01/2025
15	ISSUE FOR PERMITTING	04/01/2025
16	ISSUE FOR PERMITTING	04/01/2025
17	ISSUE FOR PERMITTING	04/01/2025
18	ISSUE FOR PERMITTING	04/01/2025
19	ISSUE FOR PERMITTING	04/01/2025
20	ISSUE FOR PERMITTING	04/01/2025
21	ISSUE FOR PERMITTING	04/01/2025
22	ISSUE FOR PERMITTING	04/01/2025
23	ISSUE FOR PERMITTING	04/01/2025
24	ISSUE FOR PERMITTING	04/01/2025
25	ISSUE FOR PERMITTING	04/01/2025
26	ISSUE FOR PERMITTING	04/01/2025
27	ISSUE FOR PERMITTING	04/01/2025
28	ISSUE FOR PERMITTING	04/01/2025
29	ISSUE FOR PERMITTING	04/01/2025
30	ISSUE FOR PERMITTING	04/01/2025

DATE ISSUED 04/01/2025
ISSUED BY [Signature]
CHECKED BY [Signature]
APPROVED BY [Signature]

PROJECT NEW ANTENNA LAYOUT
DATE 04/01/2025
TIME 10:00 AM
PROJECT NEW ANTENNA LAYOUT

SCALE 1:50
SCALE 1:50

ANTENNA AND RU SCHEDULE/ANTENNA LAYOUT
 SHEET NUMBER
A-3

<p>KATHREIN - 500-10961K</p>		<p>QUANTEL - OS8556-36</p>
------------------------------	--	----------------------------

<p>DC SURGE SUPPRESSION</p>	<p>RAYCAP DCR-18-8C-24 DC-EV</p>	<p>ERISSON RRU5 - 4415 B30</p>
-----------------------------	----------------------------------	--------------------------------

<p>RRU-E2 B29</p>	<p>ERISSON RRU5-4478 B14</p>	<p>ANTENNA MOUNTING</p>
-------------------	------------------------------	-------------------------

<p>RRU-4415 B30</p> <p>ERISSON RRU5-E2 B29</p>	<p>RRU-4449 B5012</p>	<p>RRU MOUNTING</p> <p>ERISSON BASEBAND - 6630</p>
--	-----------------------	--

<p>BBU5218</p>	<p>RRU-8043 B2966A</p> <p>ERISSON BASEBAND - 5218</p>	<p>ANTENNA</p> <p>60000</p> <p>50000</p> <p>40000</p> <p>30000</p> <p>20000</p> <p>10000</p> <p>0</p>
----------------	---	---

<p>DATE ORDERED: []</p> <p>DATE SHIPPED: []</p> <p>DATE DELIVERED: []</p> <p>DELIVERY LOCATION: []</p>		<p>DAVE LERED LUNDAL</p> <p>ENGINEER/INSTALLATION</p> <p>C: 503.647.1786</p> <p>309 ALBERTA AVE</p> <p>LORNING, CA 94556</p>	<p>EQUIPMENT SPECIFICATIONS</p> <p>MARK NUMBER: A-6</p>	<p>at&t</p> <p>1432 ERICSSON AVE, 3RD FLOOR</p> <p>ROSTON, CA 94785</p>	<p>Ericsson</p> <p>1432 ERICSSON AVE, 3RD FLOOR</p> <p>ROSTON, CA 94785</p>
--	--	--	---	---	---

EMERSON NETBURSE - 312 DC POWER SYSTEM

DC POWER SYSTEM FEATURES:
 Output: 312A, 312B, 312C, 312D, 312E, 312F, 312G, 312H, 312I, 312J, 312K, 312L, 312M, 312N, 312O, 312P, 312Q, 312R, 312S, 312T, 312U, 312V, 312W, 312X, 312Y, 312Z, 312AA, 312AB, 312AC, 312AD, 312AE, 312AF, 312AG, 312AH, 312AI, 312AJ, 312AK, 312AL, 312AM, 312AN, 312AO, 312AP, 312AQ, 312AR, 312AS, 312AT, 312AU, 312AV, 312AW, 312AX, 312AY, 312AZ, 312BA, 312BB, 312BC, 312BD, 312BE, 312BF, 312BG, 312BH, 312BI, 312BJ, 312BK, 312BL, 312BM, 312BN, 312BO, 312BP, 312BQ, 312BR, 312BS, 312BT, 312BU, 312BV, 312BW, 312BX, 312BY, 312BZ, 312CA, 312CB, 312CC, 312CD, 312CE, 312CF, 312CG, 312CH, 312CI, 312CJ, 312CK, 312CL, 312CM, 312CN, 312CO, 312CP, 312CQ, 312CR, 312CS, 312CT, 312CU, 312CV, 312CW, 312CX, 312CY, 312CZ, 312DA, 312DB, 312DC, 312DD, 312DE, 312DF, 312DG, 312DH, 312DI, 312DJ, 312DK, 312DL, 312DM, 312DN, 312DO, 312DP, 312DQ, 312DR, 312DS, 312DT, 312DU, 312DV, 312DW, 312DX, 312DY, 312DZ, 312EA, 312EB, 312EC, 312ED, 312EE, 312EF, 312EG, 312EH, 312EI, 312EJ, 312EK, 312EL, 312EM, 312EN, 312EO, 312EP, 312EQ, 312ER, 312ES, 312ET, 312EU, 312EV, 312EW, 312EX, 312EY, 312EZ, 312FA, 312FB, 312FC, 312FD, 312FE, 312FF, 312FG, 312FH, 312FI, 312FJ, 312FK, 312FL, 312FM, 312FN, 312FO, 312FP, 312FQ, 312FR, 312FS, 312FT, 312FU, 312FV, 312FW, 312FX, 312FY, 312FZ, 312GA, 312GB, 312GC, 312GD, 312GE, 312GF, 312GG, 312GH, 312GI, 312GJ, 312GK, 312GL, 312GM, 312GN, 312GO, 312GP, 312GQ, 312GR, 312GS, 312GT, 312GU, 312GV, 312GW, 312GX, 312GY, 312GZ, 312HA, 312HB, 312HC, 312HD, 312HE, 312HF, 312HG, 312HH, 312HI, 312HJ, 312HK, 312HL, 312HM, 312HN, 312HO, 312HP, 312HQ, 312HR, 312HS, 312HT, 312HU, 312HV, 312HW, 312HX, 312HY, 312HZ, 312IA, 312IB, 312IC, 312ID, 312IE, 312IF, 312IG, 312IH, 312II, 312IJ, 312IK, 312IL, 312IM, 312IN, 312IO, 312IP, 312IQ, 312IR, 312IS, 312IT, 312IU, 312IV, 312IW, 312IX, 312IY, 312IZ, 312JA, 312JB, 312JC, 312JD, 312JE, 312JF, 312JG, 312JH, 312JI, 312JJ, 312JK, 312JL, 312JM, 312JN, 312JO, 312JP, 312JQ, 312JR, 312JS, 312JT, 312JU, 312JV, 312JW, 312JX, 312JY, 312JZ, 312KA, 312KB, 312KC, 312KD, 312KE, 312KF, 312KG, 312KH, 312KI, 312KJ, 312KK, 312KL, 312KM, 312KN, 312KO, 312KP, 312KQ, 312KR, 312KS, 312KT, 312KU, 312KV, 312KW, 312KX, 312KY, 312KZ, 312LA, 312LB, 312LC, 312LD, 312LE, 312LF, 312LG, 312LH, 312LI, 312LJ, 312LK, 312LL, 312LM, 312LN, 312LO, 312LP, 312LQ, 312LR, 312LS, 312LT, 312LU, 312LV, 312LW, 312LX, 312LY, 312LZ, 312MA, 312MB, 312MC, 312MD, 312ME, 312MF, 312MG, 312MH, 312MI, 312MJ, 312MK, 312ML, 312MM, 312MN, 312MO, 312MP, 312MQ, 312MR, 312MS, 312MT, 312MU, 312MV, 312MW, 312MX, 312MY, 312MZ, 312NA, 312NB, 312NC, 312ND, 312NE, 312NF, 312NG, 312NH, 312NI, 312NJ, 312NK, 312NL, 312NM, 312NN, 312NO, 312NP, 312NQ, 312NR, 312NS, 312NT, 312NU, 312NV, 312NW, 312NX, 312NY, 312NZ, 312OA, 312OB, 312OC, 312OD, 312OE, 312OF, 312OG, 312OH, 312OI, 312OJ, 312OK, 312OL, 312OM, 312ON, 312OO, 312OP, 312OQ, 312OR, 312OS, 312OT, 312OU, 312OV, 312OW, 312OX, 312OY, 312OZ, 312PA, 312PB, 312PC, 312PD, 312PE, 312PF, 312PG, 312PH, 312PI, 312PJ, 312PK, 312PL, 312PM, 312PN, 312PO, 312PP, 312PQ, 312PR, 312PS, 312PT, 312PU, 312PV, 312PW, 312PX, 312PY, 312PZ, 312QA, 312QB, 312QC, 312QD, 312QE, 312QF, 312QG, 312QH, 312QI, 312QJ, 312QK, 312QL, 312QM, 312QN, 312QO, 312QP, 312QQ, 312QR, 312QS, 312QT, 312QU, 312QV, 312QW, 312QX, 312QY, 312QZ, 312RA, 312RB, 312RC, 312RD, 312RE, 312RF, 312RG, 312RH, 312RI, 312RJ, 312RK, 312RL, 312RM, 312RN, 312RO, 312RP, 312RQ, 312RR, 312RS, 312RT, 312RU, 312RV, 312RW, 312RX, 312RY, 312RZ, 312SA, 312SB, 312SC, 312SD, 312SE, 312SF, 312SG, 312SH, 312SI, 312SJ, 312SK, 312SL, 312SM, 312SN, 312SO, 312SP, 312SQ, 312SR, 312SS, 312ST, 312SU, 312SV, 312SW, 312SX, 312SY, 312SZ, 312TA, 312TB, 312TC, 312TD, 312TE, 312TF, 312TG, 312TH, 312TI, 312TJ, 312TK, 312TL, 312TM, 312TN, 312TO, 312TP, 312TQ, 312TR, 312TS, 312TT, 312TU, 312TV, 312TW, 312TX, 312TY, 312TZ, 312UA, 312UB, 312UC, 312UD, 312UE, 312UF, 312UG, 312UH, 312UI, 312UJ, 312UK, 312UL, 312UM, 312UN, 312UO, 312UP, 312UQ, 312UR, 312US, 312UT, 312UU, 312UV, 312UW, 312UX, 312UY, 312UZ, 312VA, 312VB, 312VC, 312VD, 312VE, 312VF, 312VG, 312VH, 312VI, 312VJ, 312VK, 312VL, 312VM, 312VN, 312VO, 312VP, 312VQ, 312VR, 312VS, 312VT, 312VU, 312VV, 312VW, 312VX, 312VY, 312VZ, 312WA, 312WB, 312WC, 312WD, 312WE, 312WF, 312WG, 312WH, 312WI, 312WJ, 312WK, 312WL, 312WM, 312WN, 312WO, 312WP, 312WQ, 312WR, 312WS, 312WT, 312WU, 312WV, 312WW, 312WX, 312WY, 312WZ, 312XA, 312XB, 312XC, 312XD, 312XE, 312XF, 312XG, 312XH, 312XI, 312XJ, 312XK, 312XL, 312XM, 312XN, 312XO, 312XP, 312XQ, 312XR, 312XS, 312XT, 312XU, 312XV, 312XW, 312XX, 312XY, 312XZ, 312YA, 312YB, 312YC, 312YD, 312YE, 312YF, 312YG, 312YH, 312YI, 312YJ, 312YK, 312YL, 312YM, 312YN, 312YO, 312YP, 312YQ, 312YR, 312YS, 312YT, 312YU, 312YV, 312YW, 312YX, 312YY, 312YZ, 312ZA, 312ZB, 312ZC, 312ZD, 312ZE, 312ZF, 312ZG, 312ZH, 312ZI, 312ZJ, 312ZK, 312ZL, 312ZM, 312ZN, 312ZO, 312ZP, 312ZQ, 312ZR, 312ZS, 312ZT, 312ZU, 312ZV, 312ZW, 312ZX, 312ZY, 312ZZ

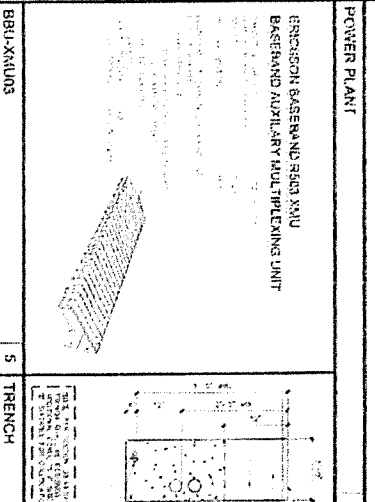
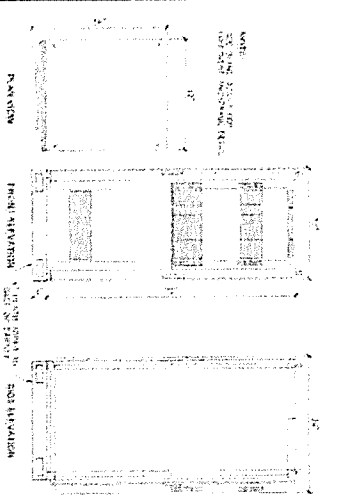
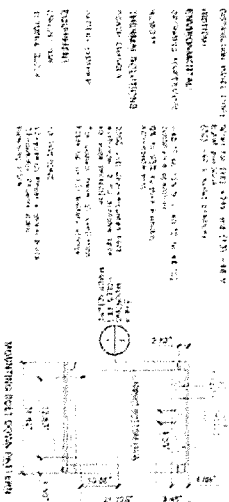

EMERSON NETBURSE - 312 DC POWER SYSTEM
 Mechanical Specifications
 Cabinet Height: 72" (1828 mm)
 Cabinet Width: 19" (482 mm)
 Cabinet Depth: 22" (558 mm)
 Weight: 150 lbs (68 kg)
 Material: Steel
 Finish: Powder Coat
 Mounting: 19" EIA Standard
 Rack Mounting: 19" EIA Standard
 Power Input: 3-Phase 480V AC
 Power Output: 3-Phase 480V AC
 Cooling: Forced Air
 Noise: 65 dBA (1m)
 Environmental: 0 to 50°C (32 to 122°F)
 Humidity: 5% to 95% RH (non-condensing)
 Vibration: 0.5 g (10-200 Hz)
 Shock: 10 g (100 Hz - 1000 Hz)
 Seismic: 0.1 g (0.5 Hz - 10 Hz)
 Safety: Class II, Type B
 Compliance: FCC Part 15, Class B
 CE Marked
 RoHS Compliant
 Lead-Free
 REACH Compliant
 ISO 9001:2015
 ISO 14001:2015
 ISO 45001:2018

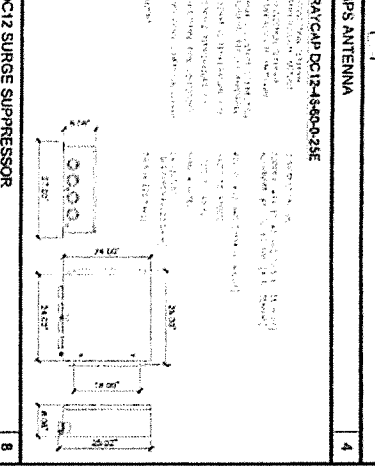
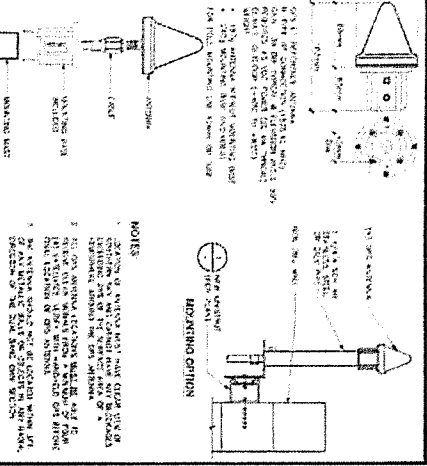
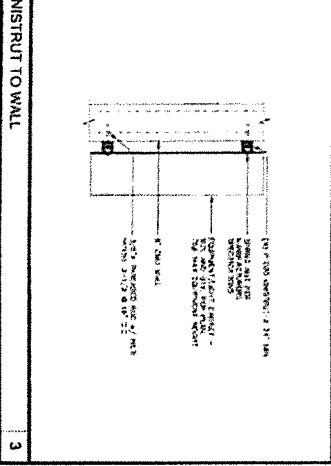
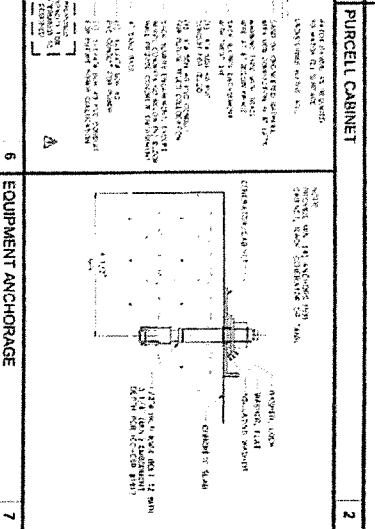
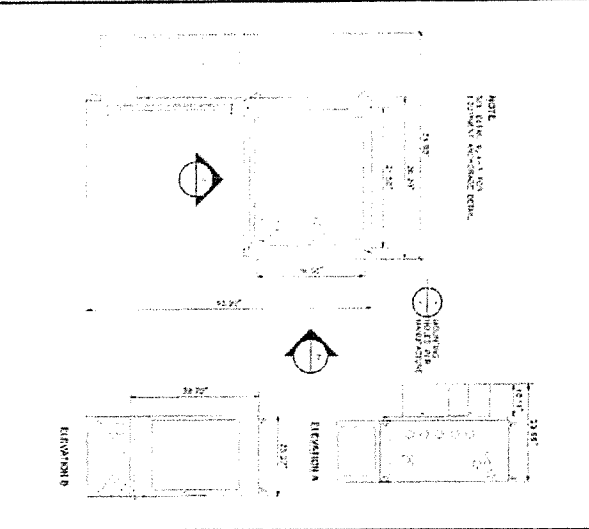

at&t
 1425 BERRY AVE, 5TH FLOOR
 SAN JOSE, CA 95131

Eukon
 95 POST SQAIE 1800
 IRVINE, CA 92614
 TEL: (949) 258-8566
 www.eukon.com

REVISION	DATE	DESCRIPTION
1	01/15/2018	ISSUED FOR CONSTRUCTION
2	02/01/2018	REVISED TO ADD DIMENSIONS
3	03/01/2018	REVISED TO ADD NOTES
4	04/01/2018	REVISED TO ADD MATERIALS

DATE ISSUED: 11/13/18

PROJECT INFORMATION
 PROJECT NO: 18-001
 CLIENT: AT&T
 LOCATION: SAN JOSE, CA

EQUIPMENT SPECIFICATIONS
 PART NUMBER: A-7

EXHIBIT E

ATTACHMENT B: CONDITIONS OF APPROVAL

Conditional Use Permit Staff Report for AT&T New Facility at Albiero Avenue
Case No. 19CUP-00000-00022
July 29, 2020

I. PROJECT DESCRIPTION

1. **Proj Des-01 Project Description.** This Conditional Use Permit is based upon and limited to compliance with the project description, the hearing exhibits marked A-I, dated July 29, 2020, and all conditions of approval set forth below, specified plans and agreements included by reference, as well as all applicable County rules and regulations. The project description is as follows:

The project includes a request by AT&T (the applicant) for a Conditional Use Permit to authorize the construction and operation of an unmanned telecommunications facility pursuant to Section 35.82.060 and Chapter 35.44 of the LUDC for property zoned RR-10. The facility would be sited on a 730-square foot lease area of a 6.94-acre parcel (APN 097-371-051) owned by the County of Santa Barbara, located approximately 1,500 feet south of the entrance to Cabrillo High School in the Lompoc area, Third Supervisorial District.

The unmanned wireless facility would include nine, 8 ft.-tall panel antennas in three sectors oriented in azimuths of 50, 150, and 275 degrees with four antennas per sector. The antennas are directional and would be mounted at a 53-ft. center height on a proposed 57-ft. tall monopole. All support equipment, including equipment cabinets, mounted equipment, a transformer, and a backup generator for the facility, would be located at the base of the structure within a proposed 8-ft. tall CMU-block equipment enclosure. The generator would only be used during maintenance and in the event of an emergency. The facility would comply with all FCC standards for health and safety, and the effective radiated power of the antennas would not be in excess of the FCC's general public limit at the nearest walking surface to each antenna.

The equipment would be serviced by 750 feet of new utility lines extending from an existing utility pole. New utility line would be located in a 3-ft. wide trench. The proposed facility would require approximately 15 cu. yd. of cut and 107 cu. yd. of fill for utility trenching and monopole foundation work.

Access to the facility would be provided via an existing driveway from the end of Albiero Avenue. A parking area immediately east of the facility would be utilized for routine maintenance. The facility would be secured by an 8-ft tall CMU-block enclosure with a locked access gate enclosing the lease area. The entire facility (excluding the utility trenching and parking area) would be contained in the lease area. The project would include new vegetative landscaping around the lease area to provide additional screening at varying heights. Vegetation would include two 24" box Coast Live Oaks (*Quercus agrifolia*), three 5-gal toyon (*Heteromeles*

arbutifolia), and seven 5-gal San Bruno coffeeberry (*Frangula rhamnus*). All protected trees on the property would be preserved. Protected trees (on the basis of their status as mature native trees) in the project area include a double-trunk Coast Live Oak. The protected oak would be fenced with tree protection fencing beginning approximately five feet from the lease area boundary. No trees would be removed.

With the exception of security lights, no exterior lighting is proposed. Two twin security lights would be motion sensor-operated. The security lights would be wall-mounted and directed downward to light only the interior of the lease area.

Any deviations from the project description, exhibits or conditions must be reviewed and approved by the County for conformity with this approval. Deviations may require approved changes to the permit and/or further environmental review. Deviations without the above described approval will constitute a violation of permit approval.

2. **Proj Des-02 Project Conformity.** The grading, development, use, and maintenance of the property, the size, shape, arrangement, and location of the structures, parking areas and landscape areas, and the protection and preservation of resources shall conform to the project description above and the hearing exhibits and conditions of approval below. The property and any portions thereof shall be sold, leased or financed in compliance with this project description and the approved hearing exhibits and conditions of approval thereto. All plans (such as Landscape and Tree Protection Plans) must be submitted for review and approval and shall be implemented as approved by the County.

II. PROJECT SPECIFIC CONDITIONS

3. **Aest-04 BAR Required.** The Applicant shall obtain Board of Architectural Review (BAR) approval for project design. All project elements (e.g., design, scale, character, colors, materials and landscaping shall be compatible with vicinity development and shall conform in all respects to BAR approval (19BAR-00000-00095). **TIMING:** The Applicant shall submit architectural drawings of the project for review and shall obtain final BAR approval prior to issuance of Zoning Clearance. Grading plans, if required, shall be submitted to P&D concurrent with or prior to BAR plan filing.

MONITORING: The Applicant shall demonstrate to P&D compliance monitoring staff that the project has been built consistent with approved BAR design and landscape plans prior to Final Building Inspection Clearance.

4. **Tel-03 Colors and Painting.** All exposed equipment and facilities (i.e., antennas, support structure, equipment cabinets, etc.) shall be finished (or left unfinished to achieve the same purpose) in non-reflective materials (including painted surfaces) as follows:
 - 1) All ancillary and support equipment shall be concealed behind the 8-ft. tall CMU block enclosure with gated entry.

- 2) The equipment enclosure and gated entry shall be finished in light grey.
- 3) The monopole shall be finished as galvanized steel or in a non-reflective medium grey color to achieve the same effect.
- 4) All other visible surfaces of the facility (including antennas) will have a non-reflective medium grey finish.

PLAN REQUIREMENTS: Color and material specifications shall be approved by NBAR and identified on final zoning plans submitted by the Permittee to the County prior to Issuance of Zoning Clearance, as well as on final building plans. **MONITORING:** P&D compliance monitoring staff shall conduct a Project Compliance Inspection prior to Final Building Inspection Clearance.

5. **Tel-05 Exterior Lighting.** Except as otherwise noted in the Project Description and development plans, the antenna support structure shall not be lighted. The leased premises shall likewise be unlit except for three motion-detector operated lights on a timer, which limit lighting to the area of the equipment in the immediate vicinity of the antenna support structure. The light fixtures shall be fully shielded, fully cut-off and downcast so as to avoid spillage onto adjacent areas and shall be kept off except when maintenance personnel are actually present at night. **PLAN REQUIREMENTS:** The Permittee shall restate the lighting limitations on the construction plans. Plans for exterior lighting, if any are provided, shall be submitted to the County for review and approval. **TIMING:** This condition shall be satisfied prior to Issuance of Zoning Clearance.

MONITORING: P&D compliance monitoring staff shall conduct a Project Compliance Inspection prior to Final Building Inspection Clearance and respond to any complaints.

6. **Tel-06 Underground Utilities.** Except as otherwise noted in the Project Description and development plans, all utilities necessary for facility operation, including coaxial cable, shall be placed underground. Conduit shall be sized so as provide additional capacity to accommodate utilities for other telecommunication carriers should collocation be pursued in the future. **PLAN REQUIREMENTS:** The Permittee shall restate the provisions for utility undergrounding on all building and grading plans. **TIMING:** This condition shall be satisfied prior to Issuance of Zoning Clearance.

MONITORING: P&D staff shall check plans prior to Issuance of Zoning Clearance.

7. **CulRes-09 Stop Work at Encounter.** The Applicant and/or their agents, representatives or contractors shall stop or redirect work immediately in the event archaeological remains are encountered during grading, construction, landscaping or other construction-related activity. The Applicant shall immediately contact P&D staff, and retain a P&D approved archaeologist and Native American representative to evaluate the significance of the find in compliance with the provisions of the County Archaeological Guidelines and conduct appropriate mitigation funded by the Applicant. **PLAN REQUIREMENTS:** This condition shall be printed on all building and grading plans.

MONITORING: P&D permit processing planner shall check plans prior to Issuance of Zoning Clearance and P&D compliance monitoring staff shall spot check in the field throughout grading and construction.

8. **Air-01 Dust Control.** The Applicant shall comply with the following dust control components at all times including weekends and holidays:
- a. Dust generated by the development activities shall be kept to a minimum with a goal of retaining dust on the site.
 - b. During clearing, grading, earth moving, excavation, or transportation of cut or fill materials, use water trucks or sprinkler systems to prevent dust from leaving the site and to create a crust after each day's activities cease.
 - c. During construction, use water trucks or sprinkler systems to keep all areas of vehicle movement damp enough to prevent dust from leaving the site.
 - d. Wet down the construction area after work is completed for the day and whenever wind exceeds 15 mph.
 - e. When wind exceeds 15 mph, have site watered at least once each day including weekends and/or holidays.
 - f. Order increased watering as necessary to prevent transport of dust off-site.
 - g. Cover soil stockpiled for more than two days or treat with soil binders to prevent dust generation. Reapply as needed.
 - h. If the site is graded and left undeveloped for over four weeks, the Applicant shall immediately: (i) Seed and water to re-vegetate graded areas; and/or (ii) Spread soil binders; and/or; (iii) Employ any other method(s) deemed appropriate by P&D or APCD.

PLAN REQUIREMENTS: These dust control requirements shall be noted on all grading and building plans. **PRE-CONSTRUCTION REQUIREMENTS:** The contractor or builder shall provide P&D monitoring staff and APCD with the name and contact information for an assigned onsite dust control monitor(s) who has the responsibility to:

- a. Assure all dust control requirements are complied with including those covering weekends and holidays.
- b. Order increased watering as necessary to prevent transport of dust offsite.
- c. Attend the pre-construction meeting.

TIMING: The dust monitor shall be designated prior to first Building Permit. The dust control components apply from the beginning of any grading or construction throughout all development activities until Final Building Inspection Clearance is issued.

MONITORING: P&D processing planner shall ensure measures are on plans. P&D grading and building inspectors shall spot check; Grading and Building shall ensure compliance onsite. APCD inspectors shall respond to nuisance complaints.

9. **Bio-20 Equipment Storage-Construction.** The Applicant shall designate one or more construction equipment filling and storage areas to contain spills facilitate clean-up and proper disposal and prevent contamination from discharging to the storm drains, street,

drainage ditches, creeks, or wetlands. The areas shall be no larger than 50 x 50 foot unless otherwise approved by P&D and shall be located at least 100 feet from any storm drain, waterbody or sensitive biological resources. **PLAN REQUIREMENTS:** The Applicant shall designate the P&D approved location on all Zoning Clearance and Building Permit plans.

TIMING: The Applicant shall install the area prior to commencement of construction. **MONITORING:** P&D compliance monitoring staff shall ensure compliance prior to and throughout construction.

10. **Bio-20a Equipment Washout-Construction.** The Applicant shall designate one or more washout areas for the washing of concrete trucks, paint, equipment, or similar activities to prevent wash water from discharging to the storm drains, street, drainage ditches, creeks, or wetlands. Note that polluted water and materials shall be contained in these areas and removed from the site as needed. The areas shall be located at least 100 feet from any storm drain, waterbody or sensitive biological resources.

PLAN REQUIREMENTS: The Applicant shall designate the P&D approved location on all Zoning Clearance and Building Permit plans. **TIMING:** The Applicant shall install the area prior to commencement of construction. **MONITORING:** P&D compliance monitoring staff shall ensure compliance prior to and throughout construction.

11. **Noise-02 Construction Hours.** The Applicant, including all contractors and subcontractors shall limit construction activity, including equipment maintenance and site preparation, to the hours between 7:00 a.m. and 5:00 p.m. Monday through Friday. No construction shall occur on weekends or State holidays. Non-noise generating interior construction activities such as plumbing, electrical, drywall and painting (which does not include the use of compressors, tile saws, or other noise-generating equipment) are not subject to these restrictions. Any subsequent amendment to the Comprehensive General Plan, applicable Community or Specific Plan, or Zoning Code noise standard upon which these construction hours are based shall supersede the hours stated herein. **PLAN REQUIREMENTS:** The Applicant shall provide and post a sign stating these restrictions at all construction site entries. **TIMING:** Signs shall be posted prior to commencement of construction and maintained throughout construction. **MONITORING:** The Applicant shall demonstrate that required signs are posted prior to grading/building permit issuance and pre-construction meeting. Building inspectors and permit compliance staff shall spot check and respond to complaints.

12. **Parking-02 Onsite Construction Parking.** All construction-related vehicles, equipment staging and storage areas shall be located on the subject parcel and outside of the road and highway right of way. The Applicant shall provide all construction personnel with a written notice of this requirement and a description of approved parking, staging and storage areas. The notice shall also include the name and phone number of the Applicant's designee responsible for enforcement of this restriction. **PLAN REQUIREMENTS:** Designated construction personnel parking, equipment staging and storage areas shall be

depicted on project plans submitted for Zoning Clearance. **TIMING:** A copy of the written notice shall be submitted to P&D permit processing staff prior to Issuance of Zoning Clearance. This restriction shall be maintained throughout construction.

MONITORING: P&D permit compliance and Building and Safety shall confirm the availability of designated onsite areas during construction, and as required, shall require re-distribution of updated notices and/or refer complaints regarding offsite parking to appropriate agencies.

13. **Tel-08 FCC Compliance.** The facility shall be operated in strict conformance with: (i) all rules, regulations, standards and guidance published by the Federal Communications Commission ("FCC"), including but not limited to, safety signage, Maximum Permissible Exposure ("MPE") Limits, and any other similar requirements to ensure public protection or (ii) all other legally binding, more restrictive standards subsequently adopted by federal agencies having jurisdiction. Compliance shall be governed by the following:
 - a. Permittee shall hire a qualified professional acceptable to the County (wholly independent of Permittee), to perform radio frequency ("RF") field test that measures actual RF electromagnetic exposure at the site. This RF field-testing shall measure all ambient sources of RF energy at the site & report the cumulative RF exposure, including contributions from the site together with other sources of RF energy in the environment as a whole. Measurements shall be made by the responsible professional who will author the report to the County. Report of the results and the author's/professional's findings with respect to compliance with federally established MPE standards shall be submitted to the County w/in 30 days of Final Building Clearance. Permittee shall pay for the cost of the field measurements and preparing the report. The facility shall cease & desist commercial operations until it complies with, or has been modified to comply with, applicable RF standards.
 - b. Every 5 years, Permittee shall hire a qualified professional acceptable to the County to perform RF field testing to evaluate compliance with current federally established MPE standards. In the event the adopted RF standards change, Permittee shall submit a report with calculations of the maximum potential public RF exposure from the Project with respect to the revised RF public exposure standards, w/in 90 days of the date the change becomes effective. If calculated levels exceed 80% of the applicable RF standards, Permittee shall notify the County and submit a MPE compliance verification report with the results from current RF field-testing at the site. Permittee shall pay for the cost of preparing the reports. For joint-carrier sites, cumulative reporting may be delegated to one carrier upon the agreement of all carriers at the site. Procedures, penalties & remedies for non-compliance with these reporting requirements shall be governed by the provisions of the Telecom Ordinance & FCC regulations.

- c. Prior to the addition/replacement of equipment which has the potential to increase RF emissions at any public location beyond that estimated in the initial application and is w/in the scope of the project description, Permittee shall submit a report providing the calculation of predicted maximum effective radiated power including the new equipment as well as the maximum cumulative potential public RF exposure expressed as a percentage of the public MPE limit attributable to the site as a whole. Once the new equipment has been installed, Permittee shall perform Initial Verification as stated in "1" above.

PLAN REQUIREMENTS: All building plans shall include provisions for MPE compliance. **TIMING:** Initial verification of compliance with RF public MPE standards shall be accomplished no later than 30 days following Final Building Clearance. Continued verification of compliance with MPE requirements shall be accomplished by RF field test reports submitted every 5 years following initial verification.

MONITORING: P&D planner shall review all RF field test reports and estimated maximum cumulative RF exposure reports providing calculations of predicted compliance with the public MPE standard. P&D planner shall monitor changes in RF standards, as well as equipment modifications, additions & RF exposures at the site as reported by the Applicant that might trigger the requirement for field-testing at intervening times between regular test periods.

14. **Tel-09 Project Review.** Five years after Issuance of the Zoning Clearance for the project and no more frequently than every five years thereafter, the Director of P&D may undertake inspection of the project and require the Permittee to modify its facilities subject to the following parameters:
 - a. **Modification Criteria.** Modifications may be required if, at the time of inspection it is determined that: (i) the Project fails to achieve the intended purposes of the development standards listed in the Telecommunications Ordinance for reasons attributable to design or changes in environmental setting; or (ii) more effective means of ensuring aesthetic compatibility with surrounding uses become available as a result of subsequent technological advances or changes in circumstance from the time the Project was initially approved.
 - b. **Modification Limits.** The Director's decision shall take into account the availability of new technology, capacity and coverage requirements of the Permittee, and new facilities installed in the vicinity of the site. The scope of modification, if required, may include, but not be limited to a reduction in antenna size and height, collocation at an alternate permitted site, and similar site and architectural design changes. However, the Permittee shall not be required to undertake changes that exceed ten percent (10%) of the total cost of facility construction. The decision of the Director as to modifications required herein shall be deemed final unless appealed in compliance with the provisions of the County Code.

PLAN REQUIREMENTS: The Permittee shall restate the provisions for emissions compliance on all building plans. **TIMING:** Building permit valuation data shall be used for the purpose establishing the estimated cost of installing the facility. At the time of subsequent inspection and upon reasonable notice, the Permittee shall furnish supplemental documentation as necessary to evaluate new technology, capacity and coverage requirements of the Permittee.

MONITORING: P&D compliance monitoring staff shall conduct periodic inspections and ascertain whether more effective mitigation is available with regard to design and technology. In the event of violation, the permit shall be referred to Zoning Enforcement for abatement.

15. **Tel-10 Collocation.** The Permittee shall avail its facility and site to other telecommunication carriers and, in good faith, accommodate all reasonable requests for collocation in the future subject to the following parameters: (i) the party seeking the collocation shall be responsible for all facility modifications, environmental review, Mitigation Measures, associated costs and permit processing; (ii) the Permittee shall not be required to compromise the operational effectiveness of its facility or place its prior approval at risk; (iii) the Permittee shall make its facilities and site available for collocation on a non-discriminatory and equitable cost basis; and (iv) the County retains the right to verify that the use of the Permittee's facilities and site conforms to County policies.
16. **Tel-11 Transfer of Ownership.** In the event that the Permittee sells or transfers its interest in the telecommunications facility, the Permittee and/or succeeding carrier shall assume all responsibilities concerning the Project and shall be held responsible by the County for maintaining consistency with all conditions of approval. The succeeding carrier shall immediately notify the County and provide accurate contact and billing information to the County for remaining compliance work for the life of the facility.

PLAN REQUIREMENTS: The Permittee shall notify the County of changes in ownership to any or all of the telecommunications facility. **TIMING:** Notification of changes in facility ownership shall be given by the Permittee and/or succeeding carrier to the County within 30 days of such change.

17. **Tel-12 Site Identification.** The Permittee shall clearly identify each piece of equipment installed at a site with the Permittee's name and site number to distinguish from other telecommunication carriers' equipment, including but not limited to: antennas, microwave dishes, equipment shelters, support poles, and cabinetry. The Permittee shall be responsible for clearly marking with permanent paint, tags, or other suitable identification all facility equipment belonging to the Permittee as stated on the site plans.

TIMING: This condition shall be satisfied prior to Final Building Inspection Clearance.

MONITORING: P&D permit processing planner shall check plans and P&D compliance

monitoring staff shall conduct compliance inspections as needed to ensure permit compliance.

18. **Tel-13 Facility Maintenance.** The facility shall be maintained in a state of good condition at all times. This includes, but is not limited to: painting; site identification; equipment repair; and keeping the facility clear of debris, trash, and graffiti.
19. **Landsep-01a Landscape for Life.** The Project Applicant shall maintain landscaping for the life of the project. Should the Coast Live Oak tree used to screen the facility die in the future, it shall be replaced by the applicant with a native tree of comparable size, species, and density. The facility owner or designee shall permit the County to conduct site inspections a minimum of one time per year. **MONITORING:** P&D compliance monitoring staff may conduct site inspections once per year if necessary to ensure that landscaping is maintained for the life of the project.
20. **Tel-15 Agreement to Comply.** The facility owner shall sign and record an agreement to comply with the project description and all conditions of approval on a form acceptable to P&D. Such form may be obtained from the P&D office prior to Issuance of Zoning Clearance. The Applicant shall provide evidence that he/she has recorded the Agreement to Comply with Conditions.
21. **Tel-16 Abandonment-Revocation.** The Permittee shall remove all support structures, antennas, equipment and associated improvements and restore the site to its natural pre-construction state within one year of discontinuing use of the facility, upon permit revocation, or upon termination or expiration of a lease authorizing use of the site. Should the Permittee require more than one year to complete removal and restoration activities after discontinuance the Permittee shall apply for a one-time time extension for removal. In the event the Owner requests that the facility or structures remain, the Owner must apply for necessary permits for those structures within one year of discontinued use, if applicable. Compliance shall be governed by the following provisions:
 - a. Prior to Issuance of Zoning Clearance, the Permittee shall post a performance security. The security shall equal 10 percent of the installation value of the facility as determined at the time of granting the building permit. The performance security shall be retained until this condition is fully satisfied.
 - b. Prior to demolition of the facility, the Permittee shall submit a restoration plan of proposed abandonment to be reviewed and approved by a County approved biologist.
 - c. If use of the facility is discontinued for a period of more than one year and the facility is not removed and no time extension has been applied for and/or granted, the County may remove the facility at the Permittee's expense.

III. COUNTY RULES AND REGULATIONS

22. **Rules-01 Effective Date-Not Appealable to CCC.** This Conditional Use Permit shall become effective upon the date of the expiration of the applicable appeal period provided an appeal has not been filed. If an appeal has been filed, the planning permit shall not be deemed effective until final action by the final review authority on the appeal. No entitlement for the use or development shall be granted before the effective date of the planning permit. [LUDC §35.82.020]
23. **Rules-03 Additional Permits Required.** The use and/or construction of any structures or improvements authorized by this approval shall not commence until the all necessary planning and building permits are obtained. Before any Permit will be issued by Planning and Development, the Owner/Applicant must obtain written clearance from all departments having conditions; such clearance shall indicate that the Owner/Applicant has satisfied all pre-construction conditions. A form for such clearance is available from Planning and Development.
24. **Rules-05 Acceptance of Conditions.** The Owner/Applicant's acceptance of this permit and/or commencement of use, construction and/or operations under this permit shall be deemed acceptance of all conditions of this permit by the Owner/Applicant.
25. **Rules-12 CUP Expiration.** The Owner/Applicant shall obtain the required Zoning Clearance within the 18 months following the effective date of this Conditional Use Permit. If the required Zoning Clearance is not issued within the 18 months following the effective date of this Conditional Use Permit, or within such extended period of time as may be authorized in compliance with Section 35.84.030.D of the County Land Use and Development Code, and an application for an extension has not been submitted to the Planning and Development Department, then Conditional Use Permit shall be considered void and of no further effect.
26. **Rules-17 CUP-Void.** This Conditional Use Permit shall become void and be automatically revoked if the development and/or authorized use allowed by this Conditional Use Permit is discontinued for a period of more than 12 months, or within such extended period of time as may be authorized in compliance with Section 35.84.030.D.1.b of the County Land Use and Development Code. Any use authorized by this Conditional Use Permit shall immediately cease upon expiration or revocation of this Conditional Use Permit. Any Zoning Clearance approved or issued pursuant to this Conditional Use Permit shall expire upon expiration or revocation of the Conditional Use Permit. Conditional Use Permit renewals must be applied for prior to expiration of the Conditional Use Permit. [LUDC §35.82.060 & §35.84.060]
27. **Rules-18 CUP and DVP Revisions.** The approval by the County Planning Commission of a revised Conditional Use Permit shall automatically supersede any previously approved Conditional Use Permit upon the effective date of the revised permit.
28. **Rules-22 Leased Facilities.** The Operator is responsible for complying with all conditions of approval contained in this Conditional Use Permit. Any zoning violations concerning

the installation, operation, and/or abandonment of the facility are the responsibility of the Owner and the Operator.

29. **Rules-23 Processing Fees Required.** Prior to issuance of a Zoning Clearance, the Owner/Applicant shall pay all applicable P&D permit processing fees in full as required by County ordinances and resolutions.
30. **Rules-30 Plans Requirements.** The Owner/Applicant shall ensure all applicable final conditions of approval are printed in their entirety on applicable pages of grading/construction or building plans submitted to P&D or Building and Safety Division. These shall be graphically illustrated where feasible.
31. **Rules-31 Condition Compliance Monitoring Required.** The Owner/Applicant shall ensure that the project complies with all approved plans and all project conditions including those which must be monitored after the project is built and occupied. To accomplish this, the Owner/Applicant shall:
 - a. Contact P&D compliance staff as soon as possible after project approval to provide the name and phone number of the future contact person for the project and give estimated dates for future project activities;
 - b. Sign a separate Agreement to Pay for compliance monitoring costs and remit a security deposit prior to approval of the Zoning Clearance as authorized by ordinance and fee schedules. Compliance monitoring costs will be invoiced monthly and may include costs for P&D to hire and manage outside consultants when deemed necessary by P&D staff (e.g. non-compliance situations, special monitoring needed for sensitive areas including but not limited to biologists, archaeologists) to assess damage and/or ensure compliance. In such cases, the Owner/Applicant shall comply with P&D recommendations to bring the project into compliance. The decision of the Director of P&D shall be final in the event of a dispute. Monthly invoices shall be paid by the due date noted on the invoice;
 - c. Note the following on each page of grading and building plans "This project is subject to Condition Compliance Monitoring and Reporting. All aspects of project construction shall adhere to the approved plans, notes, and conditions of approval;
 - d. Contact P&D compliance staff at least two weeks prior to commencement of construction activities to schedule an on-site pre-construction meeting to be led by P&D Compliance Monitoring staff and attended by all parties deemed necessary by P&D, including the permit issuing planner, grading and/or building inspectors, other agency staff, and key construction personnel: contractors, sub-contractors and contracted monitors among others.
32. **Rules-32 Contractor and Subcontractor Notification.** The Owner/Applicant shall ensure that potential contractors are aware of County requirements. Owner / Applicant

shall notify all contractors and subcontractors in writing of the site rules, restrictions, and Conditions of Approval and submit a copy of the notice to P&D compliance monitoring staff.

33. **Rules-33 Indemnity and Separation.** The Owner/Applicant shall defend, indemnify and hold harmless the County or its agents or officers and employees from any claim, action or proceeding against the County or its agents, officers or employees, to attack, set aside, void, or annul, in whole or in part, the County's approval of this project.
34. **Rules-37 Time Extensions-All Projects.** The Owner / Applicant may request a time extension prior to the expiration of the permit or entitlement for development. The review authority with jurisdiction over the project may, upon good cause shown, grant a time extension in compliance with County rules and regulations, which include reflecting changed circumstances and ensuring compliance with CEQA. If the Owner / Applicant requests a time extension for this permit, the permit may be revised to include updated language to standard conditions and/or mitigation measures and additional conditions and/or mitigation measures which reflect changed circumstances or additional identified project impacts.
35. **Activities Outside of Lease Area.** Prior issuance of the Zoning Clearance, the Applicant shall provide a lease agreement acceptable to and approved by County Counsel and Planning and Development demonstrating that the Applicant is authorized to use the site, including provisions authorizing ingress, egress, parking, vehicular maneuvering, utilities, temporary fencing, and other construction-related activities required outside of the lease area for construction, operation and maintenance of the facility as described in the Project Description and Conditions of Approval.