

Recording requested by and when recorded mail to:
County of Santa Barbara
Public Works Department
Laguna County Sanitation District
620 West Foster Road
Santa Maria, CA 93455
Attn: Martin Wilder

**COUNTY OF SANTA BARBARA
OFFICIAL BUSINESS**

No fee pursuant to Government Code § 6103
No recording fee per Government Code § 27383

SPACE ABOVE THIS LINE FOR RECORDER'S USE
Easement on APN 129-290-013

The undersigned grantor declares DOCUMENTARY TRANSFER TAX \$ <u>zero (0)</u> EXEMPTION (R&T CODE) <u>§11922</u> EXPLANATION <u>Municipal government agency</u>

EASEMENT DEED

MIGUEL GUERRA, JR. AND GABRIELA GUERRA, HUSBAND AND WIFE AS JOINT TENANTS; as GRANTOR herein,

FOR A VALUABLE CONSIDERATION, DO HEREBY GRANT TO the LAGUNA COUNTY SANITATION DISTRICT, a county sanitation district of the State of California, as GRANTEE herein, a permanent easement and right of way for present and future construction, reconstruction, operation, repair, and maintenance of improvements required by GRANTEE for GRANTEE's operations related to sewer line improvements, in such number and size, and with such accessory parts and structures, and with all surface and subsurface appurtenances incidental thereto, as GRANTEE, or its successors in interest, may from time to time deem necessary to install within the easement, together with necessary rights of ingress and egress to the easement for the above-referenced purposes, in, on, along, under and through that certain land situated in the County of Santa Barbara, State of California, more particularly described in Exhibit "A" (the "Legal Description") and shown on Exhibit "B" attached hereto and incorporated by this reference subject to the following terms and conditions:

GRANTOR and its successors in interest retain the right to full use of the easement area except that within the easement area no structures or buildings can be erected or other use made which would interfere with or be inconsistent with the use of the easement for the purposes described herein.

GRANTOR agrees to indemnify, defend and hold harmless GRANTEE and its officers, officials, employees, agents and volunteers from and against any and all claims, actions, losses, damages, judgments and/or liabilities arising out of this Deed from any cause whatsoever, including the acts, errors or omissions of any person or entity and for any costs or expenses (including but not

limited to reasonable attorneys' fees) incurred by GRANTEE on account of any claim except where such indemnification is caused by the sole negligence or willful misconduct of the GRANTEE.

Date: 2-18 -, 2020

GRANTOR:

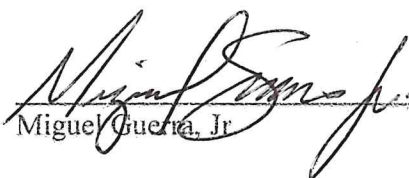
Miguel Guerra, Jr.

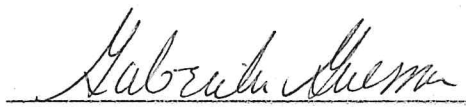
Gabriela Guerra

ACKNOWLEDGMENT

A notary public or other officer completing this certificate verifies only the identity of the individual who signed the document to which this certificate is attached, and not the truthfulness, accuracy, or validity of that document.

State of California)
County of Santa Barbara)

On FEB. 18, 2020 before me, MARTHA BENDAW, a Notary Public, personally appeared Miguel Guerra, Jr. who proved to me on the basis of satisfactory evidence to be the person(s) whose name(s) is/are subscribed to within the instrument and acknowledged to me that he/she/they executed the same in his/her/their authorized capacity(ies), and that by his/her/their signature(s) on the instrument the person(s), or the entity upon behalf of which the person(s) acted, executed the instrument.

I certify under PENALTY OF PERJURY under the laws of the State of California that the foregoing paragraph is true and correct.

WITNESS my hand and official seal.

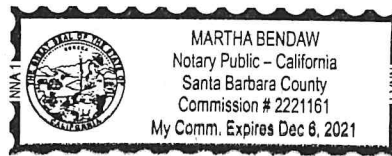

Signature *M Bendaw*

(Seal)

ACKNOWLEDGMENT

A notary public or other officer completing this certificate verifies only the identity of the individual who signed the document to which this certificate is attached, and not the truthfulness, accuracy, or validity of that document.

State of California)
County of Santa Barbara)

On FEB 18, 2020 before me, MARTHA BENDAW, a Notary Public, personally appeared Gabriela Guerra, who proved to me on the basis of satisfactory evidence to be the person(s) whose name(s) is/are subscribed to within the instrument and acknowledged to me that he/she/they executed the same in his/her/their authorized capacity(ies), and that by his/her/their signature(s) on the instrument the person(s), or the entity upon behalf of which the person(s) acted, executed the instrument.

I certify under PENALTY OF PERJURY under the laws of the State of California that the foregoing paragraph is true and correct.

WITNESS my hand and official seal.

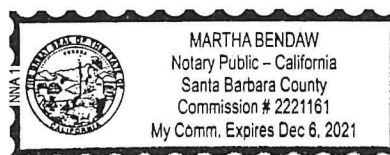

Signature *MBendaw*

(Seal)

CERTIFICATE OF ACCEPTANCE

STATE OF CALIFORNIA, COUNTY OF SANTA BARBARA: Gov. Code § 27281

THIS IS TO CERTIFY that the interest in real property conveyed by the Easement Deed dated _____, 2020, from MIGUEL GUERRA, JR. AND GARBRIELA GUERRA, HUSBAND AND WIFE AS JOINT TENANTS; as GRANTOR, to the LAGUNA COUNTY SANITATION DISTRICT, a county sanitation district of the State of California, is hereby accepted by order of the Board of Directors of the Laguna County Sanitation District on _____, 2020 and the Laguna County Sanitation District as GRANTEE consents to recordation thereof by its duly authorized officer.

WITNESS my hand and official seal

this _____ day of _____, 2020

MONA MIYASATO
COUNTY EXECUTIVE OFFICER
EX-OFFICIO CLERK OF THE BOARD

By: _____
Deputy

APPROVED AS TO FORM
MICHAEL C. GHIZZONI

By: _____
Lina Somait, Deputy County Counsel

EXHIBIT "A"

APN 129-290-013
EASEMENT FOR SEWER PURPOSES
LEGAL DESCRIPTION

THE NORTHERLY 30 FEET OF PARCEL "A" OF PARCEL MAP NO. 13117 AS SHOWN ON THE MAP RECORDED IN BOOK 33 PAGE 81 OF PARCEL MAPS, ON FILE IN THE OFFICE OF THE COUNTY RECORDER OF SANTA BARBARA COUNTY.

AREA = 3,003 SQUARE FEET, MORE OR LESS



LC ENGINEERING GROUP, INC.
CONSULTING ENGINEERS
889 Pierce Court, Suite 101, Thousand Oaks, California 91360
818-991-7148 • 805-497-1244 • lcegroupinc.com • workfiles@lcegroupinc.com



9/25/2019

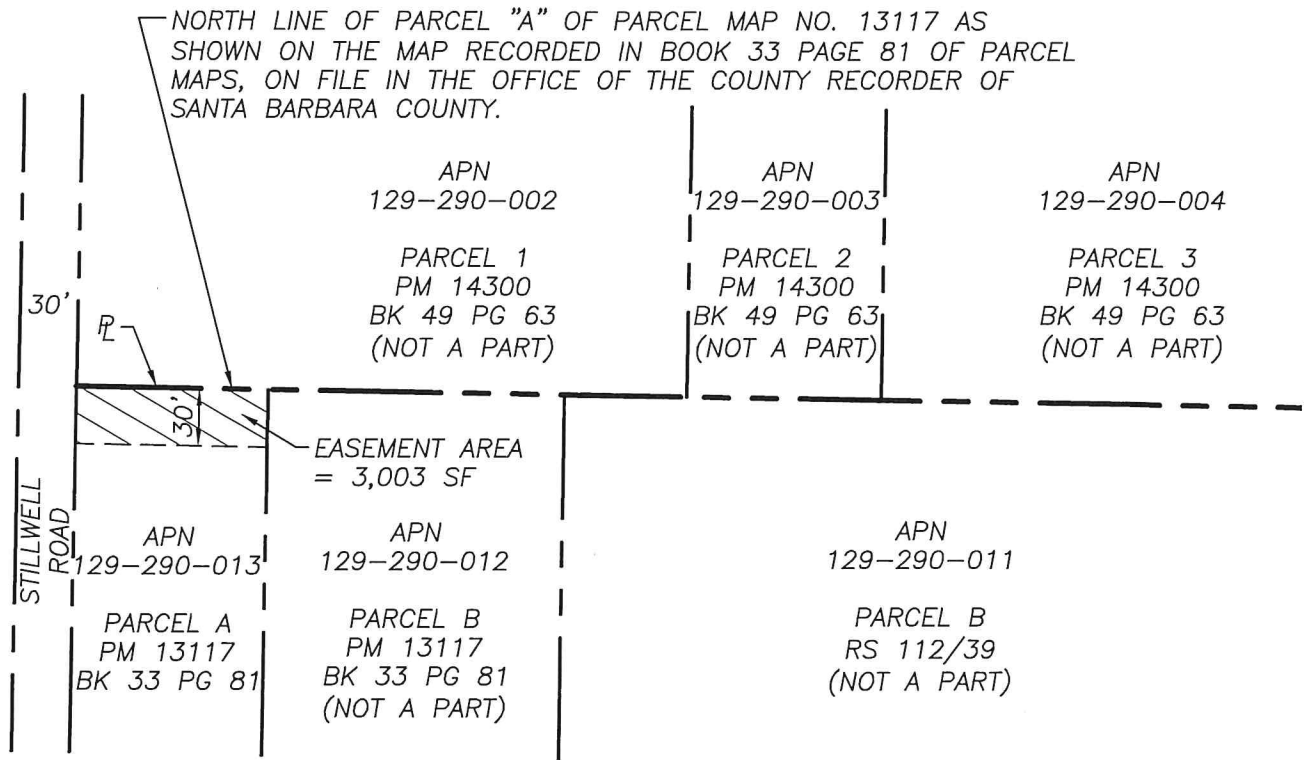

SCALE: 1"=100'



LC ENGINEERING GROUP, INC.

CONSULTING ENGINEERS

889 Pierce Court, Suite 101, Thousand Oaks, California 91360
 818-991-7148 • 805-497-1244 • lcegroupinc.com • workfiles@lcegroupinc.com



9/25/2019