

## **AGREEMENT FOR SERVICES OF INDEPENDENT CONTRACTOR**

**THIS AGREEMENT** (hereafter Agreement) is made by and between the County of Santa Barbara, a political subdivision of the State of California (hereafter COUNTY) and Northeast-Western Energy Systems USA LLC (AKA NES-WES) with an address at 499 Nibus Street, Unit B, Brea, CA 92821(hereafter CONTRACTOR) wherein CONTRACTOR agrees to provide and COUNTY agrees to accept the services specified herein.

**WHEREAS**, the COUNTY owns the ReSource Center which has onsite four combined heat and power (CHP) engines powered by landfill gas and biogas generated by the ReSource Center's anaerobic digestion facility. The County took direct control over these engines in January 2024 and have been working with the CONTRACTOR on deferred maintenance and repair to get them fully operational. CONTRACTOR is a wholly owned, indirect subsidiary of INNIO Group Holding GmbH, which also wholly-owns the CHP engine manufacturer INNIO Jenbacher GmbH & Co OG, based in Austria (the "Manufacturer").

WHEREAS, Contractor is an affiliate and an authorized channel partner for the distribution of Manufacturer's engines, products, and related parts as well as an authorized provider of aftermarket parts, warranty and repair services and equipment maintenance services; and

**WHEREAS**, CONTRACTOR represents that it is specially trained, skilled, experienced, and competent to perform the special services required by COUNTY and COUNTY desires to retain the services of CONTRACTOR pursuant to the terms, covenants, and conditions herein set forth;

**NOW, THEREFORE**, in consideration of the mutual covenants and conditions contained herein, the parties agree as follows:

### **1. DESIGNATED REPRESENTATIVE**

John Hancock at phone number 805-882-3619 is the representative of COUNTY and will administer this Agreement for and on behalf of COUNTY. Alfred Clark at phone number 215-435-0242 is the authorized representative for CONTRACTOR. Changes in designated representatives shall be made only after advance written notice to the other party.

### **2. NOTICES**

Any notice or consent required or permitted to be given under this Agreement shall be given to the respective parties in writing, by personal delivery or facsimile, or with postage prepaid by first class mail, registered or certified mail, or express courier service, as follows:

To COUNTY:  
ATTN: John Hancock, Compliance Manager  
Resource Recovery & Waste Management Division, Public Works  
130 East Victoria Street, Suite 100  
Santa Barbara CA 93101  
Email: jhancoc@countyofsb.org  
Phone: 805-882-3619

To CONTRACTOR:

ATTN: Jeremy Webb, Director, Aftermarket Sales and Business Development

Northeast-Western Energy Systems USA LLC

499 Nibus Street, Unit B, Brea, CA 92821

Email: jwebb@nes-wes.com

Mobile: 209-415-0132 FAX : 714-529-9701

or at such other address or to such other person that the parties may from time to time designate in accordance with this Notices section. If sent by first class mail, notices and consents under this section shall be deemed to be received five (5) days following their deposit in the U.S. mail. This Notices section shall not be construed as meaning that either party agrees to service of process except as required by applicable law.

### **3. SCOPE OF SERVICES**

CONTRACTOR agrees to provide services to COUNTY in accordance with EXHIBIT A and the scope of work detailed in Exhibit A-1, both of which are attached hereto and incorporated herein by reference.

### **4. TERM**

CONTRACTOR shall commence performance on January 1, 2025, and end performance upon completion, but no later than December 31, 2029, unless otherwise directed by COUNTY or unless earlier terminated.

### **5. COMPENSATION OF CONTRACTOR**

In full consideration for CONTRACTOR's services, CONTRACTOR shall be paid for performance under this Agreement in accordance with the terms of EXHIBIT B attached hereto and incorporated herein by reference. Billing shall be made by invoice, which shall include the contract number assigned by COUNTY and which is delivered to the address given in Section 2 NOTICES above following completion of the increments identified on EXHIBIT B. Unless otherwise specified on EXHIBIT B, payment shall be net thirty (30) days from presentation of invoice.

### **6. INDEPENDENT CONTRACTOR**

It is mutually understood and agreed that CONTRACTOR (including any and all of its officers, agents, and employees), shall perform all of its services under this Agreement as an independent contractor as to COUNTY and not as an officer, agent, servant, employee, joint venturer, partner, or associate of COUNTY. Furthermore, COUNTY shall have no right to control, supervise, or direct the manner or method by which CONTRACTOR shall perform its work and function. However, COUNTY shall retain the right to administer this Agreement so as to verify that CONTRACTOR is performing its obligations in accordance with the terms and conditions hereof. CONTRACTOR understands and acknowledges that it shall not be entitled to any of the benefits of a COUNTY employee, including but not limited to vacation, sick leave, administrative leave, health insurance, disability insurance, retirement, unemployment insurance, workers' compensation and protection of tenure. CONTRACTOR shall be solely liable and responsible for providing to, or on behalf of, its employees all legally-required employee benefits. In addition, CONTRACTOR shall be solely responsible and save COUNTY harmless from all matters relating to payment of CONTRACTOR's employees, including compliance with Social Security withholding and all other regulations governing such matters. It is acknowledged that during the term of this Agreement, CONTRACTOR may be providing services to others unrelated to the COUNTY or to this Agreement.

### **7. STANDARD OF PERFORMANCE**

CONTRACTOR represents that it has the skills, expertise, and licenses/permits necessary to perform the services required under this Agreement. Accordingly, CONTRACTOR shall perform all such services in the manner and according to the standards observed by a competent practitioner of the same profession in which CONTRACTOR is engaged. All products of whatsoever nature, which CONTRACTOR delivers to COUNTY pursuant to this Agreement, shall be prepared in a first class and workmanlike manner and shall conform to the standards of quality normally

observed by a person practicing in CONTRACTOR's profession. CONTRACTOR shall correct or revise any errors or omissions, at COUNTY'S request without additional compensation. Permits and/or licenses shall be obtained and maintained by CONTRACTOR without additional compensation.

**8. DEBARMENT AND SUSPENSION**

CONTRACTOR certifies to COUNTY that it and its employees and principals are not debarred, suspended, or otherwise excluded from or ineligible for, participation in federal, state, or county government contracts. CONTRACTOR certifies that it shall not contract with a subcontractor that is so debarred or suspended.

**9. TAXES**

CONTRACTOR shall pay all taxes, levies, duties, and assessments of every nature due in connection with any work under this Agreement and shall make any and all payroll deductions required by law. COUNTY shall not be responsible for paying any taxes on CONTRACTOR's behalf, and should COUNTY be required to do so by state, federal, or local taxing agencies, CONTRACTOR agrees to promptly reimburse COUNTY for the full value of such paid taxes plus interest and penalty, if any. These taxes shall include, but not be limited to, the following: FICA (Social Security), unemployment insurance contributions, income tax, disability insurance, and workers' compensation insurance.

**10. CONFLICT OF INTEREST**

CONTRACTOR covenants that CONTRACTOR presently has no employment or interest and shall not acquire any employment or interest, direct or indirect, including any interest in any business, property, or source of income, which would conflict in any manner or degree with the performance of services required to be performed under this Agreement. CONTRACTOR further covenants that in the performance of this Agreement, no person having any such interest shall be employed by CONTRACTOR. CONTRACTOR must promptly disclose to COUNTY, in writing, any potential conflict of interest. COUNTY retains the right to waive a conflict of interest disclosed by CONTRACTOR if COUNTY determines it to be immaterial, and such waiver is only effective if provided by COUNTY to CONTRACTOR in writing.

**11. OWNERSHIP OF DOCUMENTS AND INTELLECTUAL PROPERTY**

COUNTY shall be the owner of the following items incidental to this Agreement upon production, whether or not completed: all data collected, all documents of any type whatsoever, all photos, designs, sound or audiovisual recordings, software code, inventions, technologies, and other materials, and any material necessary for the practical use of such items, from the time of collection and/or production whether or not performance under this Agreement is completed or terminated prior to completion. CONTRACTOR shall not release any of such items to other parties except after prior written approval of COUNTY.

Unless otherwise specified in Exhibit A, CONTRACTOR hereby assigns to COUNTY all copyright, patent, and other intellectual property and proprietary rights to all data, documents, reports, photos, designs, sound or audiovisual recordings, software code, inventions, technologies, and other materials prepared or provided by CONTRACTOR pursuant to this Agreement (collectively referred to as "Copyrightable Works and Inventions"). COUNTY shall have the unrestricted authority to copy, adapt, perform, display, publish, disclose, distribute, create derivative works from, and otherwise use in whole or in part, any Copyrightable Works and Inventions. CONTRACTOR agrees to take such actions and execute and deliver such documents as may be needed to validate, protect and confirm the rights and assignments provided hereunder. CONTRACTOR warrants that any Copyrightable Works and Inventions and other items provided under this Agreement will not infringe upon any intellectual property or proprietary rights of any third party. CONTRACTOR at its own expense shall defend, indemnify, and hold harmless COUNTY against any claim that any Copyrightable Works or Inventions or other items provided by CONTRACTOR hereunder infringe upon intellectual or other proprietary rights of a third party, and CONTRACTOR shall pay any damages, costs, settlement amounts, and fees (including attorneys' fees) that may be incurred by COUNTY in connection with any such claims. This Ownership of Documents and Intellectual Property provision shall survive expiration or termination of this Agreement.

**12. NO PUBLICITY OR ENDORSEMENT**

CONTRACTOR shall not use COUNTY's name or logo or any variation of such name or logo in any publicity, advertising or promotional materials. CONTRACTOR shall not use COUNTY's name or logo in any manner that would give the appearance that the COUNTY is endorsing CONTRACTOR. CONTRACTOR shall not in any way contract on behalf of or in the name of COUNTY. CONTRACTOR shall not release any informational pamphlets, notices, press releases, research reports, or similar public notices concerning the COUNTY or its projects, without obtaining the prior written approval of COUNTY.

**13. COUNTY PROPERTY AND INFORMATION**

All of COUNTY's property, documents, and information provided for CONTRACTOR's use in connection with the services shall remain COUNTY's property, and CONTRACTOR shall return any such items whenever requested by COUNTY and whenever required according to the Termination section of this Agreement. CONTRACTOR may use such items only in connection with providing the services. CONTRACTOR shall not disseminate any COUNTY property, documents, or information without COUNTY's prior written consent.

**14. RECORDS, AUDIT, AND REVIEW**

CONTRACTOR shall keep such business records pursuant to this Agreement as would be kept by a reasonably prudent practitioner of CONTRACTOR's profession and shall maintain such records for at least four (4) years following the termination of this Agreement. All accounting records shall be kept in accordance with generally accepted accounting principles. COUNTY shall have the right to audit and review all such documents and records at any time during CONTRACTOR's regular business hours or upon reasonable notice. In addition, if this Agreement exceeds ten thousand dollars (\$10,000.00), CONTRACTOR shall be subject to the examination and audit of the California State Auditor, at the request of the COUNTY or as part of any audit of the COUNTY, for a period of three (3) years after final payment under the Agreement (Cal. Govt. Code Section 8546.7). CONTRACTOR shall participate in any audits and reviews, whether by COUNTY or the State, at no charge to COUNTY.

If federal, state or COUNTY audit exceptions are made relating to this Agreement, CONTRACTOR shall reimburse all costs incurred by federal, state, and/or COUNTY governments associated with defending against the audit exceptions or performing any audits or follow-up audits, including but not limited to: audit fees, court costs, attorneys' fees based upon a reasonable hourly amount for attorneys in the community, travel costs, penalty assessments and all other costs of whatever nature. Immediately upon notification from COUNTY, CONTRACTOR shall reimburse the amount of the audit exceptions and any other related costs directly to COUNTY as specified by COUNTY in the notification.

**15. INDEMNIFICATION AND INSURANCE**

CONTRACTOR agrees to the indemnification and insurance provisions as set forth in EXHIBIT C attached hereto and incorporated herein by reference.

**16. NONDISCRIMINATION**

COUNTY hereby notifies CONTRACTOR that COUNTY's Unlawful Discrimination Ordinance (Article XIII of Chapter 2 of the Santa Barbara County Code) applies to this Agreement and is incorporated herein by this reference with the same force and effect as if the ordinance were specifically set out herein and CONTRACTOR agrees to comply with said ordinance.

17. **NONEXCLUSIVE AGREEMENT**

CONTRACTOR understands that this is not an exclusive Agreement and that COUNTY shall have the right to negotiate with and enter into contracts with others providing the same or similar services as those provided by CONTRACTOR as the COUNTY desires.

18. **NON-ASSIGNMENT**

CONTRACTOR shall not assign, transfer or subcontract this Agreement or any of its rights or obligations under this Agreement without the prior written consent of COUNTY and any attempt to so assign, subcontract or transfer without such consent shall be void and without legal effect and shall constitute grounds for termination.

19. **TERMINATION**

A. **By COUNTY.** COUNTY may, by written notice to CONTRACTOR, terminate this Agreement in whole or in part at any time, whether for COUNTY's convenience, for nonappropriation of funds, or because of the failure of CONTRACTOR to fulfill the obligations herein.

1. **For Convenience.** COUNTY may terminate this Agreement in whole or in part upon thirty (30) days written notice. During the thirty (30) day period, CONTRACTOR shall, as directed by COUNTY, wind down and cease its services as quickly and efficiently as reasonably possible, without performing unnecessary services or activities and by minimizing negative effects on COUNTY from such winding down and cessation of services.
2. **For Nonappropriation of Funds.** Notwithstanding any other provision of this Agreement, in the event that no funds or insufficient funds are appropriated or budgeted by federal, state or COUNTY governments, or funds are not otherwise available for payments in the fiscal year(s) covered by the term of this Agreement, then COUNTY will notify CONTRACTOR of such occurrence and COUNTY may terminate or suspend this Agreement in whole or in part, with or without a prior notice period. Subsequent to termination of this Agreement under this provision, COUNTY shall have no obligation to make payments with regard to the remainder of the term.
3. **For Cause.** Should CONTRACTOR default in the performance of this Agreement or materially breach any of its provisions, COUNTY may, at COUNTY's sole option, terminate or suspend this Agreement in whole or in part by written notice. Upon receipt of notice, CONTRACTOR shall immediately discontinue all services affected (unless the notice directs otherwise) and notify COUNTY as to the status of its performance. The date of termination shall be the date the notice is received by CONTRACTOR, unless the notice directs otherwise.

B. **By CONTRACTOR.** Should COUNTY fail to pay CONTRACTOR all or any part of the payment set forth in EXHIBIT B, CONTRACTOR may, at CONTRACTOR's option terminate this Agreement if such failure is not remedied by COUNTY within thirty (30) days of written notice to COUNTY of such late payment.

C. Upon termination, CONTRACTOR shall deliver to COUNTY all data, estimates, graphs, summaries, reports, and all other property, records, documents or papers as may have been accumulated or produced by CONTRACTOR in performing this Agreement, whether completed or in process, except such items as COUNTY may, by written permission, permit CONTRACTOR to retain. Notwithstanding any other payment provision of this Agreement, COUNTY shall pay CONTRACTOR for satisfactory services performed to the date of termination to include a prorated amount of compensation due hereunder less payments, if any, previously made. In no event shall CONTRACTOR be paid an amount in excess of the full price under this Agreement nor for profit on unperformed portions of service. CONTRACTOR shall furnish to COUNTY such financial information as in the judgment of COUNTY is necessary to determine the reasonable value of the

services rendered by CONTRACTOR. In the event of a dispute as to the reasonable value of the services rendered by CONTRACTOR, the decision of COUNTY shall be final. The foregoing is cumulative and shall not affect any right or remedy which COUNTY may have in law or equity.

**20. SECTION HEADINGS**

The headings of the several sections, and any Table of Contents appended hereto, shall be solely for convenience of reference and shall not affect the meaning, construction or effect hereof.

**21. SEVERABILITY**

If any one or more of the provisions contained herein shall for any reason be held to be invalid, illegal or unenforceable in any respect, then such provision or provisions shall be deemed severable from the remaining provisions hereof, and such invalidity, illegality or unenforceability shall not affect any other provision hereof, and this Agreement shall be construed as if such invalid, illegal or unenforceable provision had never been contained herein.

**22. REMEDIES NOT EXCLUSIVE**

No remedy herein conferred upon or reserved to COUNTY is intended to be exclusive of any other remedy or remedies, and each and every such remedy, to the extent permitted by law, shall be cumulative and in addition to any other remedy given hereunder or now or hereafter existing at law or in equity or otherwise.

**23. TIME IS OF THE ESSENCE**

Time is of the essence in this Agreement and each covenant and term is a condition herein.

**24. NO WAIVER OF DEFAULT**

No delay or omission of COUNTY to exercise any right or power arising upon the occurrence of any event of default shall impair any such right or power or shall be construed to be a waiver of any such default or an acquiescence therein; and every power and remedy given by this Agreement to COUNTY shall be exercised from time to time and as often as may be deemed expedient in the sole discretion of COUNTY.

**25. ENTIRE AGREEMENT AND AMENDMENT**

In conjunction with the matters considered herein, this Agreement contains the entire understanding and agreement of the parties and there have been no promises, representations, agreements, warranties or undertakings by any of the parties, either oral or written, of any character or nature hereafter binding except as set forth herein. This Agreement may be altered, amended or modified only by an instrument in writing, executed by the parties to this Agreement and by no other means. Each party waives their future right to claim, contest or assert that this Agreement was modified, canceled, superseded, or changed by any oral agreements, course of conduct, waiver or estoppel.

**26. SUCCESSORS AND ASSIGNS**

All representations, covenants and warranties set forth in this Agreement, by or on behalf of, or for the benefit of any or all of the parties hereto, shall be binding upon and inure to the benefit of such party, its successors and assigns.

**27. COMPLIANCE WITH LAW**

CONTRACTOR shall, at its sole cost and expense, comply with all County, State and Federal ordinances and statutes now in force or which may hereafter be in force with regard to this Agreement. The judgment of any court of competent jurisdiction, or the admission of CONTRACTOR in any action or proceeding against CONTRACTOR, whether COUNTY is a party thereto or not, that CONTRACTOR has violated any such ordinance or statute, shall be conclusive of that fact as between CONTRACTOR and COUNTY.

**28. CALIFORNIA LAW AND JURISDICTION**

This Agreement shall be governed by the laws of the State of California. Any litigation regarding this Agreement or its contents shall be filed in the County of Santa Barbara, if in state court, or in the federal district court nearest to Santa Barbara County, if in federal court.

**29. EXECUTION OF COUNTERPARTS**

This Agreement may be executed in any number of counterparts and each of such counterparts shall for all purposes be deemed to be an original; and all such counterparts, or as many of them as the parties shall preserve undestroyed, shall together constitute one and the same instrument.

**30. AUTHORITY**

All signatories and parties to this Agreement warrant and represent that they have the power and authority to enter into this Agreement in the names, titles and capacities herein stated and on behalf of any entities, persons, or firms represented or purported to be represented by such entity(ies), person(s), or firm(s) and that all formal requirements necessary or required by any state and/or federal law in order to enter into this Agreement have been fully complied with. Furthermore, by entering into this Agreement, CONTRACTOR hereby warrants that it shall not have breached the terms or conditions of any other contract or agreement to which CONTRACTOR is obligated, which breach would have a material effect hereon.

**31. SURVIVAL**

All provisions of this Agreement which by their nature are intended to survive the termination or expiration of this Agreement shall survive such termination or expiration.

**32. PRECEDENCE**

In the event of conflict between the provisions contained in the numbered sections of this Agreement and the provisions contained in the Exhibits, the provisions of the Exhibits shall prevail over those in the numbered sections.

Agreement for Services of Independent Contractor between the **County of Santa Barbara** and **Northeast-Western Energy Systems USA LLC**.

**IN WITNESS WHEREOF**, the parties have executed this Agreement to be effective on the date executed by COUNTY.

**ATTEST:**

Mona Miyasato  
County Executive Officer  
Clerk of the Board

**COUNTY OF SANTA BARBARA:**

By: \_\_\_\_\_  
Deputy Clerk

By: \_\_\_\_\_  
Chair, Board of Supervisors

Date: \_\_\_\_\_

**RECOMMENDED FOR APPROVAL:**

Public Works  
Chris Sneddon

**CONTRACTOR:**

Northeast-Western Energy Systems  
USA LLC

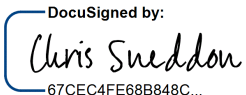
By:  \_\_\_\_\_  
Department Head

By:  \_\_\_\_\_  
Authorized Representative

Name: Al Clark

Title: Chief Executive Officer-Managing Director

**APPROVED AS TO FORM:**

Rachel Van Mullem  
County Counsel

**APPROVED AS TO ACCOUNTING FORM:**

Betsy M. Schaffer, CPA  
Auditor-Controller

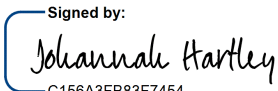
By:  \_\_\_\_\_  
Deputy County Counsel

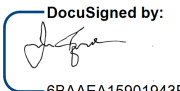
By:  \_\_\_\_\_  
Deputy

**APPROVED AS TO FORM:**

Risk Management

By:  \_\_\_\_\_  
Risk Management



**EXHIBIT A**  
**STATEMENT OF WORK**

**Complete Scope of Work is included as EXHIBIT A-1. This document includes a Long Term Service Agreement Summary, Programs, and Pricing.**

Alfred Clark and Anthony Coleman shall be the individual(s) personally responsible for providing all services hereunder. CONTRACTOR may not substitute other persons without the prior written approval of COUNTY's designated representative.

The cost allocation for each engine is as follows:

CHP Type	Engine name	Location*	11/2024 - 6/2025	7/2025 - 6/2026	7/2026 - 6/2027	7/2027 - 6/2028	7/2028 - 6/2029
Jenbacher 420	G100	MRF	\$ 162,692	\$ 127,574	\$ 135,284	\$ 418,174	\$ 133,664
Jenbacher 420	G200	MRF	\$ 124,183	\$ 438,879	\$ 151,874	\$ 158,422	\$ 151,874
Jenbacher 416	G300	ADF	\$ 121,021	\$ 180,010	\$ 141,746	\$ 377,335	\$ 141,746
Jenbacher 416	G400	ADF	\$ 155,369	\$ 151,992	\$ 377,335	\$ 141,746	\$ 145,834
		Annual Maintenance					
	Totals		\$ 563,265	\$ 898,455	\$ 806,239	\$ 1,095,677	\$ 573,118
<hr/>							
Inflation factor1		4.00%	\$ -	\$ 22,531	\$ 35,938	\$ 32,250	\$ 43,827
Sales Tax		7.75%	\$ 43,653	\$ 69,630	\$ 62,484	\$ 84,915	\$ 44,417
Total Cost			\$ 606,918	\$ 990,616	\$ 904,661	\$ 1,212,842	\$ 661,362

# Exhibit A-1

## LTSA Proposal



***NORTHEAST – WESTERN***  
***ENERGY SYSTEMS USA LLC*** →

# TABLE OF CONTENTS

**SECTION 01**  
*Long Term Service Agreement Summary.....Page 3*

**SECTION 02**  
*LTSA Programs and Pricing.....Page 4*

**SECTION 03**  
*Scope of Agreement.....Page 5*

**SECTION 04**  
*General Comments and Closing.....Page 7*

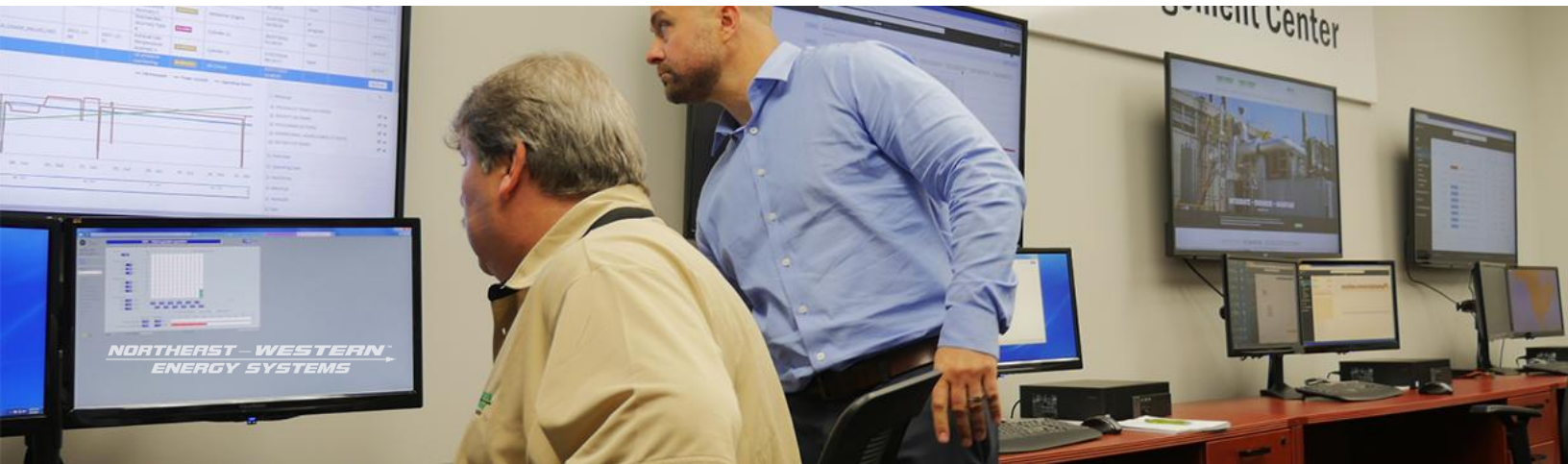

# 01 LTSA SUMMARY

January 22, 2025

## RE: Long Term Service Agreement

Dear Steve,

We are pleased to submit a Long-Term Service Agreement (LTSA) proposal for your consideration. This proposal includes LTSA program(s) suited to your RFP. Individual LTSA program details are provided in the enclosures, copies of which are provided herein. The following assumptions are factored into these offers:

**Santa Barbara LTSA on existing engines**  
**2x AB units & 2x JB units**

---

<b>Type of Equipment:</b>	2x J416's & 2x J420's - 480V – Natural gas & Biogas
<b>Equipment OPH:</b>	<b>PLEASE SEE CHARTS ON NEXT PAGE</b>
<b>Term of Agreement:</b>	~ 4,000 year – 83,000 OPH total
<b>Minimum OPH Provision:</b>	The contract price is based on expected minimum operating hours (OPH) to be reached per year. The defined yearly minimum OPH for this agreement is 3,200 (80% of expected annual OPH). We will invoice the minimum annual OPH.
<b>Validity of Proposal:</b>	The proposal is valid for sixty (60) days from the date of this proposal.
<b>Freight and Duty:</b>	Ocean and domestic inland freight charges are included.
<b>Taxes, Permits and Fees:</b>	U.S. Customs Duty is included however no allowances are made for local, state, or Federal taxes, permits, and fees.

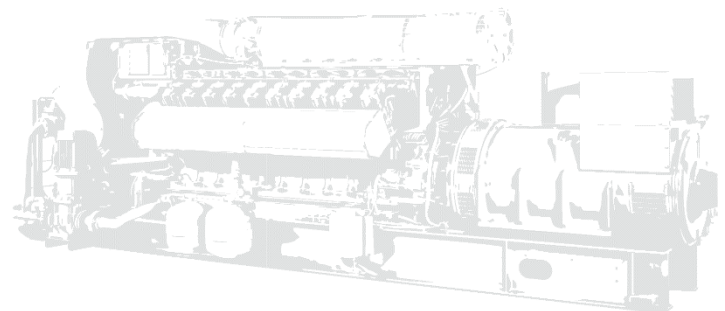



# 02

## LTSA PROGRAMS & PRICING

<b>J416 – JB TAJ1 &amp; 2 – Interval pricing</b>	<b>\$/INTERVAL/ENGINE</b>
2k:	\$8,065
10k:	\$28,018
20k:	\$288,822
30k:	\$57,321
40k:	\$302,477
Spark Plugs:	\$13,851
Remote monitoring (annual price):	\$7,500
Fluids price adder (Includes all engine oil, coolant and generator grease)	\$4.22
XT4 upgrade (Includes parts & labor):	\$29,762
NOx live monitoring with Leanox Plus:	\$10,245.92
Decoking (every year):	\$53,233
SCR maintenance (approx. annual price. See breakout Below):	\$13,700
2k Service	\$1,305.50
4k Service	\$4,932.00
6k Service	\$1,301.50
8k Service	\$6,165.00
Major Overhaul @ 60,000 OPH:	\$440,084

<b>J420 – AB Engine 1 &amp; 2 – Interval pricing</b>	<b>\$/INTERVAL/ENGINE</b>
2k:	\$9,105
10k:	\$32,897
20k:	\$342,733
30k:	\$59,781
40k:	\$360,883
Spark Plugs:	\$17,314
Remote monitoring (annual price):	\$7,500
Fluids price adder (Includes all engine oil, coolant and generator grease):	\$4.99
Decoking (every year):	\$53,233
SCR maintenance (approx. annual price. See Breakout Price Below):	\$15,770
2k Service	\$1,498.15
4k Service	\$5,667.20
6k Service	\$1,498.15
8k Service	\$7,096.50
Major Overhaul @ 60,000 OPH:	\$504,322

**\*All pricing above is on a \$/OPH/ENGINE basis. Estimated term is based off current run time hours + 8,000 OPH.**

# SCOPE OF AGREEMENT

Each program, combined with Balance of Plant Coverage, includes Field and Shop Labor, Parts and Materials for the engine generator set and the following: *(Please refer to the Included and Excluded columns)*

ADDITIONAL COMPONENTS	Included	Not Included
Container Package		X
Radiators		X
Aux./Radiator Pumps		X
Cooling System Electric Motors		X
Heat Recovery Equipment		X
SCR/Oxycatalyst		X
SCR Urea Supplied		X
Pre-Chamber Compressor		N/A
Gas Cleaning System		X
Gas Blower		X
ELECTRICAL COMPONENTS	Included	Not Included
Master Control Panel		X
Generator Set Motor Control Center		X
Generator Circuit Breaker		X
Differential/Protective Relays		X
STANDARD SERVICES	Included	Not Included
Oil Changes		
Coolant Changes		
Vibration Analysis		
Emissions Testing (Verification)		
Minor Overhaul		
Engine Batteries		
ADDITIONAL SERVICES	Included	Not Included
Major Overhaul	✓	
Generator Reconditioning (@ Overhaul)	✓	
1,000 OPH Service		X

Part of interval pricing listed above

Included as a breakout price above. *Not* included in the \$/OPH.

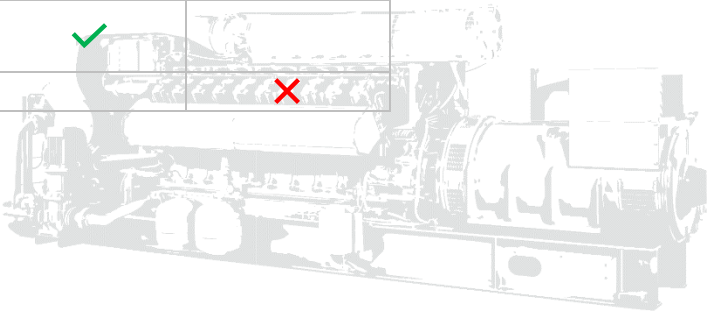

STANDARD SERVICES CONT'D	Included	Not Included
Alignment Services		
Remote Monitoring	✓	
FLUIDS/CONSUMABLES	Included	Not Included
Engine Lube Oil & Coolant Supply	✓	
Gearbox		N/A
Generator Lubricating Oil	✓	
Grease Supply	✓	
ANALYSIS KIT	Included	Not Included
Lube Oil / Kit Analysis		✗
Coolant Sample / Kit Analysis		✗
Fuel Gas Sample Kits / Analysis		✗

Part of interval pricing above

All fluids are provided as a breakout price above. *Not* included in the \$/OPH.

**Comments:** Equipment is configured with Jenbacher Diane WIN, Internet firewalls, and RMC. All connection charges are the Owner’s responsibility. Please note that the rigging is not included in the above pricing.

**Comments:** Engine lubricating oil is changed subject to Jenbacher scheduled intervals. Oil samples are required per Jenbacher scheduled intervals, no less than monthly. Oil analysis may advise increased frequency of oil change subject to fuel gas quality, wear elements, or coolant contamination. Increased demand for lube oil will result in additional charges as required.

Type 6 Gearbox lubricating oil is to be changed subject to manufacture’s requirements. Oil samples should be drawn on a regular basis, no less than quarterly. Oil analysis may advise increased frequency of oil change. Increased demand for lube oil will result in additional charges as required.

Any proposed lube oil and filter changes are included only during scheduled maintenance intervals. Routine oil level inspections and additional make-up oil are performed by Owner personnel unless we provide operating services. Additional oil and filter changes required beyond scheduled maintenance intervals, for any reason, will be additional charges as required.

**Other Equipment:** Additional Balance of Plant equipment coverage can be offered upon request.

**Annual Increases:** The Proposal will increase on an annual basis based on an agreed upon CPI, not to exceed 5% annually for the initial three (3) year period.

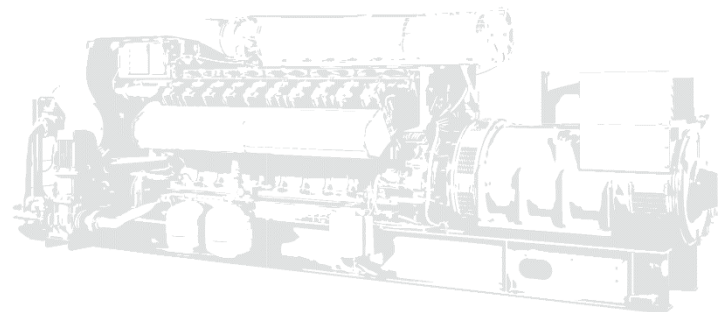

# 04 CLOSING

This proposal is subject to strictly Northeast-Western Energy Systems USA LLC Agreement for Maintenance of Equipment.

We appreciate the opportunity to submit this proposal and look forward to working with you on this project. Upon your acceptance of this proposal, we will forward a project specific Maintenance Agreement for your approval and signature. Please contact us with any of your questions.

Best regards,  
**Jeremy Webb**  
Director, Aftermarket Sales and Business Development  
**Northeast-Western Energy Systems USA LLC**

**CC : Tony Coleman, Rachel Hendricks**

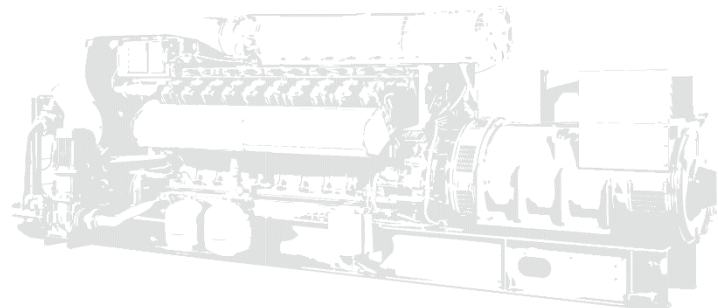



## **EXHIBIT B**

### **PAYMENT ARRANGEMENTS**

#### **Periodic Compensation**

- A. For CONTRACTOR services to be rendered under this Agreement, CONTRACTOR shall be paid a total contract amount, including cost reimbursements, not to exceed \$4,376,399.
- B. Payment for services and /or reimbursement of costs shall be made upon CONTRACTOR's satisfactory performance, based upon the scope and methodology contained in **EXHIBIT A** as determined by COUNTY.
- C. Monthly, CONTRACTOR shall submit to the COUNTY DESIGNATED REPRESENTATIVE an invoice or certified claim on the County Treasury for the service performed over the period specified. These invoices or certified claims must cite the assigned Board Contract Number. COUNTY REPRESENTATIVE shall evaluate the quality of the service performed and if found to be satisfactory shall initiate payment processing. COUNTY shall pay invoices or claims for satisfactory work within 30 days of receipt of correct and complete invoices or claims from CONTRACTOR.
- D. COUNTY's failure to discover or object to any unsatisfactory work or billings prior to payment will not constitute a waiver of COUNTY's right to require CONTRACTOR to correct such work or billings or seek any other legal remedy.

## EXHIBIT C

### Indemnification and Insurance Requirements (For Professional Contracts)

#### INDEMNIFICATION

CONTRACTOR agrees to indemnify, defend (with counsel reasonably approved by COUNTY) and hold harmless COUNTY and its officers, officials, employees, agents and volunteers from and against any and all claims, actions, losses, damages, judgments and/or liabilities arising out of this Agreement from any cause whatsoever, including the acts, errors or omissions of any person or entity and for any costs or expenses (including but not limited to attorneys' fees) incurred by COUNTY on account of any claim except where such indemnification is prohibited by law. CONTRACTOR'S indemnification obligation applies to COUNTY'S active as well as passive negligence but does not apply to COUNTY'S sole negligence or willful misconduct.

#### NOTIFICATION OF ACCIDENTS AND SURVIVAL OF INDEMNIFICATION PROVISIONS

CONTRACTOR shall notify COUNTY immediately in the event of any accident or injury arising out of or in connection with this Agreement. The indemnification provisions in this Agreement shall survive any expiration or termination of this Agreement.

#### INSURANCE

CONTRACTOR shall procure and maintain for the duration of this Agreement insurance against claims for injuries to persons or damages to property which may arise from or in connection with the performance of the work hereunder and the results of that work by the CONTRACTOR, its agents, representatives, employees or subcontractors.

##### A. Minimum Scope of Insurance

Coverage shall be at least as broad as:

1. **Commercial General Liability (CGL):** Insurance Services Office (ISO) Form CG 00 01 covering CGL on an "occurrence" basis, including products-completed operations, personal & advertising injury, with limits no less than \$1,000,000 per occurrence and \$2,000,000 in the aggregate.
2. **Automobile Liability:** Insurance Services Office Form Number CA 0001 covering, Code 1 (any auto), or if CONTRACTOR has no owned autos, Code 8 (hired) and 9 (non-owned), with limit no less than \$1,000,000 per accident for bodily injury and property damage.
3. **Workers' Compensation:** Insurance as required by the State of California, with Statutory Limits, and Employer's Liability Insurance with limit of no less than \$1,000,000 per accident for bodily injury or disease. ***(Not required if CONTRACTOR provides written verification that it has no employees)***
4. **Professional Liability:** (Errors and Omissions) Insurance appropriate to the CONTRACTOR'S profession, with limit no less than \$2,000,000 per occurrence or claim, \$2,000,000 aggregate.

If the CONTRACTOR maintains broader coverage and/or higher limits than the minimums shown above, the COUNTY requires and shall be entitled to the broader coverage and/or the higher limits maintained by the CONTRACTOR. Any available insurance proceeds in excess of the specified minimum limits of insurance and coverage shall be available to the COUNTY.

##### B. Other Insurance Provisions

The insurance policies are to contain, or be endorsed to contain, the following provisions:

1. **Additional Insured** – COUNTY, its officers, officials, employees, agents and volunteers are to be covered as additional insureds on the CGL policy with respect to liability arising out of work or operations performed by or on behalf of the CONTRACTOR including materials, parts, or equipment furnished in connection with such work or operations. General liability coverage can be provided in the form of an endorsement to the CONTRACTOR'S insurance at least as broad as ISO Form CG 20 10 11 85 or both CG 20 10, CG 20 26, CG 20 33, or CG 20 38; and CG 20 37 forms if later revisions used).
2. **Primary Coverage** – For any claims related to this contract, the CONTRACTOR'S insurance coverage shall be primary insurance primary coverage at least as broad as ISO CG 20 01 04 13 as respects the COUNTY, its officers, officials, employees, and volunteers. Any insurance or self-insurance maintained by the COUNTY, its officers, officials, employees, or volunteers shall be excess of the CONTRACTOR'S insurance and shall not contribute with it.
3. **Notice of Cancellation** – Each insurance policy required above shall provide that coverage shall not be canceled, except with notice to the COUNTY.
4. **Waiver of Subrogation Rights** – CONTRACTOR hereby grants to COUNTY a waiver of any right to subrogation which any insurer of said CONTRACTOR may acquire against the COUNTY by virtue of the payment of any loss under such insurance. CONTRACTOR agrees to obtain any endorsement that may be necessary to effect this waiver of subrogation, but this provision applies regardless of whether or not the COUNTY has received a waiver of subrogation endorsement from the insurer.
5. **Deductibles and Self-Insured Retention** – Any deductibles or self-insured retentions must be declared to and approved by the COUNTY. The COUNTY may require the CONTRACTOR to purchase coverage with a lower deductible or retention or provide proof of ability to pay losses and related investigations, claim administration, and defense expenses within the retention.
6. **Acceptability of Insurers** – Unless otherwise approved by Risk Management, insurance shall be written by insurers authorized to do business in the State of California and with a minimum A.M. Best's Insurance Guide rating of "A- VII".
7. **Verification of Coverage** – CONTRACTOR shall furnish the COUNTY with proof of insurance, original certificates and amendatory endorsements as required by this Agreement. The proof of insurance, certificates and endorsements are to be received and approved by the COUNTY before work commences. However, failure to obtain the required documents prior to the work beginning shall not waive the CONTRACTOR'S obligation to provide them. The CONTRACTOR shall furnish evidence of renewal of coverage throughout the term of the Agreement. The COUNTY reserves the right to require complete, certified copies of all required insurance policies, including endorsements required by these specifications, at any time.
8. **Failure to Procure Coverage** – In the event that any policy of insurance required under this Agreement does not comply with the requirements, is not procured, or is canceled and not replaced, COUNTY has the right but not the obligation or duty to terminate the Agreement. Maintenance of required insurance coverage is a material element of the Agreement and failure to maintain or renew such coverage or to provide evidence of renewal may be treated by COUNTY as a material breach of contract.
9. **Subcontractors** – CONTRACTOR shall require and verify that all subcontractors maintain insurance meeting all the requirements stated herein, and CONTRACTOR shall ensure that COUNTY is an additional insured on insurance required from subcontractors.
10. **Claims Made Policies** – If any of the required policies provide coverage on a claims-made basis:
  - i. The Retroactive Date must be shown and must be before the date of the contract or the beginning of contract work.
  - ii. Insurance must be maintained and evidence of insurance must be provided for at least five (5) years after completion of contract work.

- iii. If coverage is canceled or non-renewed, and not replaced with another claims-made policy form with a Retroactive Date prior to the contract effective date, the CONTRACTOR must purchase "extended reporting" coverage for a minimum of five (5) years after completion of contract work.

11. **Special Risks or Circumstances** – COUNTY reserves the right to modify these requirements, including limits, based on the nature of the risk, prior experience, insurer, coverage, or other special circumstances.

Any change requiring additional types of insurance coverage or higher coverage limits must be made by amendment to this Agreement. CONTRACTOR agrees to execute any such amendment within thirty (30) days of receipt.

Any failure, actual or alleged, on the part of COUNTY to monitor or enforce compliance with any of the insurance and indemnification requirements will not be deemed as a waiver of any rights on the part of COUNTY.