

# AGREEMENT FOR UNITED ROTORCRAFT FIXED-BELLY TANK AND LIFT CONVERSION

**UNITED ROTORCRAFT FIXED-BELLY TANK AND LIFT CONVERSION AGREEMENT** (hereafter Agreement) is made by and between the County of Santa Barbara, a political subdivision of the State of California (hereafter COUNTY) and UNITED ROTORCRAFT, a division of Air Methods Corporation, a Delaware corporation with an address at 7301 South Peoria, Englewood, CO 80112 (hereafter CONTRACTOR) wherein CONTRACTOR agrees to provide and COUNTY agrees to accept the services specified herein.

## RECITALS

- A. **WHEREAS**, CONTRACTOR represents that it is specially trained, skilled, experienced, and competent to perform the special services required by COUNTY and COUNTY desires to retain the services of CONTRACTOR pursuant to the terms, covenants, and conditions herein set forth;
- B. **WHEREAS**, CONTRACTOR is the only vendor certified to install the UR/KAWAK Firehawk Tank and High-Landing Gear Systems;
- C. **WHEREAS**, in order for the Blackhawk to undergo the final modification necessary to a Firehawk the COUNTY must contract with CONTRACTOR to complete the UR/KAWAK Firehawk Tank and High-Landing Gear Systems modifications; and
- D. **WHEREAS**, COUNTY desires to retain the services of CONTRACTOR pursuant to the terms, covenants, and conditions herein set forth.

## AGREEMENT

**NOW, THEREFORE**, in consideration of the mutual covenants and conditions contained herein, the parties agree as follows:

### **1. DESIGNATED REPRESENTATIVE**

MARK HARTWIG, FIRE CHIEF at 805-681-5501 is the representative of COUNTY and will administer this Agreement for and on behalf of COUNTY. LARRY ALEXANDRE, PRESIDENT OF UNITED ROTORCRAFT at (303) 256-4185 is the authorized representative for CONTRACTOR. Changes in designated representatives shall be made only after advance written notice to the other party.

### **2. NOTICES**

Any notice or consent required or permitted to be given under this Agreement shall be given to the respective parties in writing, by personal delivery or with postage prepaid by first class mail, registered or certified mail, or express courier service, as follows:

To COUNTY: County of Santa Barbara Fire Department, 4410 Cathedral Oaks Blvd, Santa Barbara CA 93110,  
Attn: Fire Chief

To CONTRACTOR: United Rotorcraft, 7301 South Peoria, Englewood, CO 80112, Attn: President

or at such other address or to such other person that the parties may from time to time designate in accordance with this Notices section. If sent by first class mail, notices and consents under this section shall be deemed to be received five (5) days following their deposit in the U.S. mail. This Notices section shall not be construed as meaning that either party agrees to service of process except as required by applicable law.

### **3. SCOPE OF SERVICES**

CONTRACTOR agrees to provide services to COUNTY in accordance with EXHIBIT A attached hereto and incorporated herein by reference. To the extent there are any inconsistencies between the terms of this Agreement and the terms contained in the Scope of Work or the General Terms and Conditions for Aircraft Modifications and Maintenance attached hereto as Exhibits, the terms contained in such Exhibits shall prevail.

### **4. TERM**

CONTRACTOR shall commence performance upon contract execution and end performance upon completion, but no later than June 30, 2022 unless otherwise directed by COUNTY or unless earlier terminated.

### **5. COMPENSATION OF CONTRACTOR**

In full consideration for CONTRACTOR's services, CONTRACTOR shall be paid for performance under this Agreement in accordance with the terms of EXHIBIT B attached hereto and incorporated herein by reference. Billing shall be made by invoice, which shall include the contract number assigned by COUNTY and which is delivered to the address given in Section 2 NOTICES above following completion of the increments identified on EXHIBIT B. Unless otherwise specified on EXHIBIT B, payment shall be net thirty (30) days from presentation of invoice.

### **6. INDEPENDENT CONTRACTOR**

It is mutually understood and agreed that CONTRACTOR (including any and all of its officers, agents, and employees), shall perform all of its services under this Agreement as an independent contractor as to COUNTY and not as an officer, agent, servant, employee, joint venturer, partner, or associate of COUNTY. Furthermore, COUNTY shall have no right to control, supervise, or direct the manner or method by which CONTRACTOR shall perform its work and function. However, COUNTY shall retain the right to administer this Agreement so as to verify that CONTRACTOR is performing its obligations in accordance with the terms and conditions hereof. CONTRACTOR understands and acknowledges that it shall not be entitled to any of the benefits of a COUNTY employee, including but not limited to vacation, sick leave, administrative leave, health insurance, disability insurance, retirement, unemployment insurance, workers' compensation and protection of tenure. CONTRACTOR shall be solely liable and responsible for providing to, or on behalf of, its employees all legally-required employee benefits. In addition, CONTRACTOR shall be solely responsible and save COUNTY harmless from all matters relating to payment of CONTRACTOR's employees, including compliance with Social Security withholding and all other regulations governing such matters. It is acknowledged that during the term of this Agreement, CONTRACTOR may be providing services to others unrelated to the COUNTY or to this Agreement.

### **7. STANDARD OF PERFORMANCE**

CONTRACTOR represents that it has the skills, expertise, and licenses/permits necessary to perform the services required under this Agreement. Accordingly, CONTRACTOR shall perform all such services in the manner and according to the standards observed by a competent practitioner of the same profession in which CONTRACTOR is engaged. All products of whatsoever nature, which CONTRACTOR delivers to COUNTY pursuant to this Agreement, shall be prepared in a first class and workmanlike manner and shall conform to the standards of quality normally observed by a person practicing in CONTRACTOR's profession. Permits and/or licenses shall be obtained and maintained by CONTRACTOR without additional compensation.

### **8. DEBARMENT AND SUSPENSION**

CONTRACTOR certifies to COUNTY that it and its employees and principals are not debarred, suspended, or otherwise excluded from or ineligible for, participation in federal, state, or county government contracts. CONTRACTOR certifies that it shall not contract with a subcontractor that is so debarred or suspended.

9. **CONFLICT OF INTEREST**

CONTRACTOR covenants that CONTRACTOR presently has no employment or interest and shall not acquire any employment or interest, direct or indirect, including any interest in any business, property, or source of income, which would conflict in any manner or degree with the performance of services required to be performed under this Agreement. CONTRACTOR further covenants that in the performance of this Agreement, no person having any such interest shall be employed by CONTRACTOR. CONTRACTOR must promptly disclose to COUNTY, in writing, any potential conflict of interest. COUNTY retains the right to waive a conflict of interest disclosed by CONTRACTOR if COUNTY determines it to be immaterial, and such waiver is only effective if provided by COUNTY to CONTRACTOR in writing.

10. **NO PUBLICITY OR ENDORSEMENT**

CONTRACTOR shall not use COUNTY's name or logo or any variation of such name or logo in any publicity, advertising or promotional materials. CONTRACTOR shall not use COUNTY's name or logo in any manner that would give the appearance that the COUNTY is endorsing CONTRACTOR. CONTRACTOR shall not in any way contract on behalf of or in the name of COUNTY. CONTRACTOR shall not release any informational pamphlets, notices, press releases, research reports, or similar public notices concerning the COUNTY or its projects, without obtaining the prior written approval of COUNTY (email approval is sufficient).

11. **COUNTY PROPERTY AND INFORMATION**

All of COUNTY's property, documents, and information provided for CONTRACTOR's use in connection with the services shall remain COUNTY's property, and CONTRACTOR shall return any such items whenever requested by COUNTY and whenever required according to the Termination section of this Agreement. CONTRACTOR may use such items only in connection with providing the services. CONTRACTOR shall not disseminate any COUNTY property, documents, or information marked as confidential or proprietary without COUNTY's prior written consent.

12. **RECORDS, AUDIT, AND REVIEW**

CONTRACTOR shall keep such business records pursuant to this Agreement as would be kept by a reasonably prudent practitioner of CONTRACTOR's profession and shall maintain such records for at least four (4) years following the termination of this Agreement. All accounting records shall be kept in accordance with generally accepted accounting principles. COUNTY, at its own expense, shall have the right to audit and review all such non-confidential documents and records at any time during CONTRACTOR's regular business hours upon reasonable prior written notice. In addition, if this Agreement exceeds ten thousand dollars (\$10,000.00), CONTRACTOR shall be subject to the examination and audit of the California State Auditor, at the request of the COUNTY or as part of any audit of the COUNTY, for a period of three (3) years after final payment under the Agreement (Cal. Govt. Code Section 8546.7). CONTRACTOR shall participate in any audits and reviews, whether by COUNTY or the State, at no charge to COUNTY.

If federal, state or COUNTY audit exceptions are made relating to this Agreement, based on any fraudulent, missing, or inaccurate information provided by CONTRACTOR, the CONTRACTOR shall reimburse all reasonable costs incurred by federal, state, and/or COUNTY governments directly incurred in the defense against the audit exceptions or performing any audits or follow-up audits, including but not limited to: audit fees, court costs, attorneys' fees based upon a reasonable hourly amount for attorneys in the community, travel costs, penalty assessments and all other costs of whatever nature. Immediately upon notification from COUNTY, CONTRACTOR shall reimburse the amount of the audit exceptions and any other related costs directly to COUNTY as specified by COUNTY in the notification.

### 13. INDEMNIFICATION AND INSURANCE

The parties agree to the indemnification and insurance provisions as set forth in the General Terms and Conditions for Aircraft Modifications and Maintenance attached hereto and incorporated herein by reference.

### 14. NONDISCRIMINATION

COUNTY hereby notifies CONTRACTOR that COUNTY's Unlawful Discrimination Ordinance (Article XIII of Chapter 2 of the Santa Barbara County Code) applies to this Agreement and is incorporated herein by this reference with the same force and effect as if the ordinance were specifically set out herein and CONTRACTOR agrees to comply with said ordinance.

### 15. NONEXCLUSIVE AGREEMENT

CONTRACTOR understands that this is not an exclusive Agreement and that COUNTY shall have the right to negotiate with and enter into contracts with others providing the same or similar services as those provided by CONTRACTOR as the COUNTY desires.

### 16. NON-ASSIGNMENT

CONTRACTOR shall not assign, transfer or subcontract this Agreement or any of its rights or obligations under this Agreement without the prior written consent of COUNTY and any attempt to so assign, subcontract or transfer without such consent shall be void and without legal effect and shall constitute grounds for termination; provided, however, that CONTRACTOR may, without the prior consent of the COUNTY, assign all of its rights under this Agreement to (i) a parent, subsidiary, or affiliate, or (ii) a third party participating in a merger, acquisition, sale of assets or other corporate reorganization in which CONTRACTOR is participating. If such an assignment occurs CONTRACTOR must notify the COUNTY within 30 days.

### 17. TERMINATION

- A. By COUNTY. COUNTY may, by written notice to CONTRACTOR, terminate this Agreement in whole or in part at any time, whether for COUNTY's convenience, for nonappropriation of funds, or because of the failure of CONTRACTOR to fulfill the obligations herein.
1. **For Convenience.** COUNTY may terminate this Agreement in whole or in part upon thirty (30) days written notice. During the thirty (30) day period, CONTRACTOR shall, as directed by COUNTY, wind down and cease its services as quickly and efficiently as reasonably possible, without performing unnecessary services or activities and by minimizing negative effects on COUNTY from such winding down and cessation of services. For clarification only, COUNTY's termination for convenience right is also subject to Section 12 of the General Terms and Conditions for Aircraft Modifications and Maintenance attached hereto.
  2. **For Nonappropriation of Funds.** Notwithstanding any other provision of this Agreement, in the event that this agreement extends beyond June 30, 2021, and no funds or insufficient funds are appropriated or budgeted by federal, state or COUNTY governments for such new fiscal year, or funds are not otherwise available for payments in the new fiscal year, then COUNTY will notify CONTRACTOR of such occurrence and COUNTY may terminate or suspend this Agreement in whole or in part, with or without a prior notice period. Subsequent to termination of this Agreement under this provision, COUNTY shall have no obligation to make payments with regard to the remainder of the term.
  3. **For Cause.** Should CONTRACTOR default in the performance of this Agreement or materially breach any of its provisions and fail to cure to the reasonable satisfaction of the COUNTY such default

within thirty (30) days of receipt of written notice from COUNTY specifying such default, COUNTY may, at COUNTY's sole option, terminate or suspend this Agreement in whole or in part by written notice. Upon receipt of notice, CONTRACTOR shall immediately discontinue all services affected (unless the notice directs otherwise) and notify COUNTY as to the status of its performance. COUNTY will pay CONTRACTOR for all services provided up until the date of the notice or effective date of the termination if the notice directed otherwise. The date of termination shall be the date the notice is received by CONTRACTOR, unless the notice directs otherwise.

- B. By CONTRACTOR. Should COUNTY fail to pay CONTRACTOR all or any part of the payment set forth in EXHIBIT B, or fail to comply with any other obligation hereunder, CONTRACTOR may, at CONTRACTOR's option terminate this Agreement if such failure is not remedied by COUNTY within thirty (30) days of written notice to COUNTY of such late payment or other breach.
- C. Upon termination, CONTRACTOR shall deliver to COUNTY all non-confidential data, estimates, graphs, summaries, reports, and all other records, documents or papers reasonably requested by COUNTY and in CONTRACTOR's possession that may have been accumulated or produced by CONTRACTOR in performing this Agreement, whether completed or in process. Notwithstanding any other payment provision of this Agreement, for a termination for cause COUNTY shall pay CONTRACTOR for satisfactory services performed to the date of termination to include a prorated amount of compensation due hereunder less payments, if any, previously made. In no event shall CONTRACTOR be paid an amount in excess of the full price under this Agreement nor for profit on unperformed portions of service. CONTRACTOR shall furnish to COUNTY such financial information reasonably requested by COUNTY to support CONTRACTOR's determination of the reasonable value of the services rendered by CONTRACTOR. The foregoing is cumulative and shall not affect any right or remedy which COUNTY may have in law or equity.

#### 18. SECTION HEADINGS

The headings of the several sections, and any Table of Contents appended hereto, shall be solely for convenience of reference and shall not affect the meaning, construction or effect hereof.

#### 19. SEVERABILITY

If any one or more of the provisions contained herein shall for any reason be held to be invalid, illegal or unenforceable in any respect, then such provision or provisions shall be deemed severable from the remaining provisions hereof, and such invalidity, illegality or unenforceability shall not affect any other provision hereof, and this Agreement shall be construed as if such invalid, illegal or unenforceable provision had never been contained herein.

#### 20. REMEDIES NOT EXCLUSIVE

No remedy herein conferred upon or reserved to either party is intended to be exclusive of any other remedy or remedies, and each and every such remedy, to the extent permitted by law, shall be cumulative and in addition to any other remedy given hereunder or now or hereafter existing at law or in equity or otherwise.

#### 21. TIME IS OF THE ESSENCE

Time is of the essence in this Agreement and each covenant and term is a condition herein.

#### 22. NO WAIVER OF DEFAULT

No delay or omission of either party to exercise any right or power arising upon the occurrence of any event of default shall impair any such right or power or shall be construed to be a waiver of any such default or an

acquiescence therein; and every power and remedy given by this Agreement to either party shall be exercised from time to time and as often as may be deemed expedient in the sole discretion of such party.

**23. ENTIRE AGREEMENT AND AMENDMENT**

In conjunction with the matters considered herein, this Agreement contains the entire understanding and agreement of the parties and there have been no promises, representations, agreements, warranties or undertakings by any of the parties, either oral or written, of any character or nature hereafter binding except as set forth herein. This Agreement may be altered, amended or modified only by an instrument in writing, executed by the parties to this Agreement and by no other means. Each party waives their future right to claim, contest or assert that this Agreement was modified, canceled, superseded, or changed by any oral agreements, course of conduct, waiver or estoppel.

**24. SUCCESSORS AND ASSIGNS**

All representations, covenants and warranties set forth in this Agreement, by or on behalf of, or for the benefit of any or all of the parties hereto, shall be binding upon and inure to the benefit of such party, its successors and assigns.

**25. COMPLIANCE WITH LAW**

CONTRACTOR shall, at its sole cost and expense, comply with all County, State and Federal ordinances and statutes now in force or which may hereafter be in force with regard to this Agreement. The judgment of any court of competent jurisdiction, or the admission of CONTRACTOR in any action or proceeding against CONTRACTOR, whether COUNTY is a party thereto or not, that CONTRACTOR has violated any such ordinance or statute, shall be conclusive of that fact as between CONTRACTOR and COUNTY.

**26. CALIFORNIA LAW AND JURISDICTION**

This Agreement shall be governed by the laws of the State of California. Any litigation regarding this Agreement or its contents shall be filed in the County of Santa Barbara, if in state court, or in the federal district court nearest to Santa Barbara County, if in federal court.

**27. EXECUTION OF COUNTERPARTS**

This Agreement may be executed in any number of counterparts and each of such counterparts shall for all purposes be deemed to be an original; and all such counterparts, or as many of them as the parties shall preserve undestroyed, shall together constitute one and the same instrument.

**28. AUTHORITY**

All signatories and parties to this Agreement warrant and represent that they have the power and authority to enter into this Agreement in the names, titles and capacities herein stated and on behalf of any entities, persons, or firms represented or purported to be represented by such entity(ies), person(s), or firm(s) and that all formal requirements necessary or required by any state and/or federal law in order to enter into this Agreement have been fully complied with. Furthermore, by entering into this Agreement, CONTRACTOR hereby warrants that it shall not have breached the terms or conditions of any other contract or agreement to which CONTRACTOR is obligated, which breach would have a material effect hereon.

**29. SURVIVAL**

All provisions of this Agreement which by their nature are intended to survive the termination or expiration of this Agreement shall survive such termination or expiration.

30. **PRECEDENCE**

In the event of conflict between the provisions contained in the numbered sections of this Agreement and the provisions contained in the Exhibits, the provisions of the Exhibits shall prevail over those in the numbered sections.

Agreement for Services of Independent Contractor between the **County of Santa Barbara** and United Rotorcraft.

**IN WITNESS WHEREOF**, the parties have executed this Agreement to be effective on the date executed by COUNTY.

**ATTEST:**

Mona Miyasato  
County Executive Officer  
Clerk of the Board

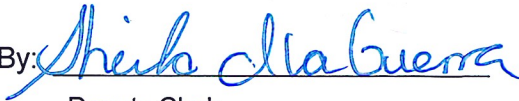
By:   
Deputy Clerk

**COUNTY OF SANTA BARBARA:**

By:   
Gregg Hart, Chair, Board of Supervisors

Date: 11-17-20

**RECOMMENDED FOR APPROVAL:**

County of Santa Barbara Fire Department

By:   
Mark Hartwig

**CONTRACTOR:**

United Rotorcraft, a division of Air Methods Corporation

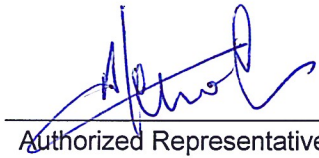
By:   
Authorized Representative

Name: Larry Alexandre

Title: President

**APPROVED AS TO FORM:**

Michael C. Ghizzoni  
County Counsel

By: \_\_\_\_\_  
Deputy County Counsel

**APPROVED AS TO ACCOUNTING FORM:**

Betsy M. Schaffer, CPA  
Auditor-Controller

By: \_\_\_\_\_  
Deputy

**APPROVED AS TO FORM:**

Risk Management

By: \_\_\_\_\_  
Risk Management



Agreement for Services of Independent Contractor between the **County of Santa Barbara** and United Rotorcraft.

**IN WITNESS WHEREOF**, the parties have executed this Agreement to be effective on the date executed by COUNTY.

**ATTEST:**

Mona Miyasato  
County Executive Officer  
Clerk of the Board

**COUNTY OF SANTA BARBARA:**

By: \_\_\_\_\_  
Deputy Clerk

By: \_\_\_\_\_  
Gregg Hart, Chair, Board of Supervisors

Date: \_\_\_\_\_

**RECOMMENDED FOR APPROVAL:**

County of Santa Barbara Fire Department

**CONTRACTOR:**

United Rotorcraft, a division of Air Methods Corporation

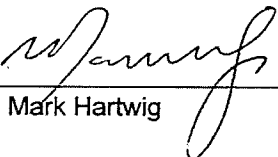
By:  \_\_\_\_\_  
Mark Hartwig

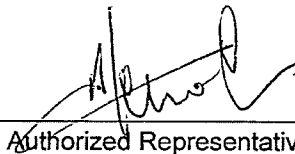
By:  \_\_\_\_\_  
Authorized Representative

Name: Larry Alexandre

Title: President

**APPROVED AS TO FORM:**

Michael C. Ghizzoni  
County Counsel

**APPROVED AS TO ACCOUNTING FORM:**

Betsy M. Schaffer, CPA  
Auditor-Controller

By:  \_\_\_\_\_  
Deputy County Counsel

By:  \_\_\_\_\_  
Robert Geis (Nov 5, 2020 09:34 PST)  
Deputy

**APPROVED AS TO FORM:**

Risk Management

Ray                      Date:  
Aromatorio,      2020.11.05  
By: Risk Manager 11:42:54 -05'00'  
Risk Management

## EXHIBIT A

### STATEMENT OF WORK

CONTRACTOR shall be the individual(s) personally responsible for providing all services hereunder. CONTRACTOR may not substitute other persons without the prior written approval of COUNTY's designated representative.

The following pages contain the CONTRACTOR STATEMENT OF WORK dated November 2, 2020 and GENERAL TERMS AND CONDITIONS FOR AIRCRAFT MODIFICATIONS AND MAINTENANCE.



**FFP Pricing Proposal**  
**For**  
**HH-60L FIREHAWK® Completion**  
**For**  
**Santa Barbara County Fire Department (SBCFD)**

Document No. GP18-024

Revision: **FFP-2**

2 NOVEMBER 2020

**PROPOSAL VALIDITY PERIOD: 30 NOVEMBER 2020**

THIS PROPOSAL SHALL NOT BE DUPLICATED, USED, OR DISCLOSED - IN WHOLE OR PART - FOR ANY PURPOSE OTHER THAN TO EVALUATE THIS PROPOSAL OR QUOTATION. IF, HOWEVER, A CONTRACT IS AWARDED TO THIS OFFEROR AS A RESULT OF - OR IN CONNECTION WITH - THE SUBMISSION OF THIS DATA, SANTA BARBARA COUNTY FIRE SHALL HAVE THE RIGHT TO DUPLICATE, USE, OR DISCLOSE THE DATA TO THE EXTENT PROVIDED IN THE RESULTING CONTRACT. THIS RESTRICTION DOES NOT LIMIT THE RIGHT TO USE INFORMATION CONTAINED IN THIS DATA IF IT IS OBTAINED FROM ANOTHER SOURCE WITHOUT RESTRICTION. THIS DOCUMENT MAY CONTAIN TECHNICAL DATA WHOSE EXPORT IS RESTRICTED BY THE ARMS EXPORT CONTROL ACT OR THE EXPORT ADMINISTRATION ACT OF 1979, AS AMENDED.

**Table of Contents**

Executive Summary ..... 4

1 Aircraft Customization Programmatic Overview ..... 5

1.1 Contract Award And Kick-Off Meeting ..... 5

1.2 Program Management ..... 5

1.3 Aircraft Completion ..... 5

1.4 Change Orders ..... 6

1.5 Aircraft Close And Testing ..... 6

1.6 Aircraft Delivery ..... 6

1.7 Airworthiness Demonstration Plan ..... 7

1.8 Quality Management System (QMS) (ISO 9001:2008 and AS9100C) ..... 8

1.9 Integrated Master Schedule - TBD ..... 8

1.10 SBCFD Provided Services ..... 9

2 Cabin Interior ..... 10

2.1 Crew Seating ..... 10

2.2 Floor Pallets ..... 10

2.3 Supply Storage Box ..... 10

2.4 Aft Cabin Stowage Compartments ..... 10

2.5 Cabin Miscellaneous Components ..... 10

3 Aerial Firefighting Mission Package (AFMP) ..... 11

3.1 High Landing Gear ..... 12

3.2 High Landing Gear (HLG) A-B Kits ..... 12

3.3 HLG A Kit (Main Landing Gear) ..... 13

3.4 HLG A Kit (Steps) ..... 13

3.5 HLG A Kit (Handholds) ..... 14

3.6 HLG B Kit (Main Landing Gear) ..... 15

3.7 HLG B Kit (Steps and Stubwing Fairings) ..... 15

3.8 HLG B Kit (Other) ..... 16

3.9 Aerial Liquid Dispensing System (ALDS) - Water Tank ..... 19

3.10 Tank A Kit Mechanical ..... 19

3.11 Tank B Kit (Drain Tubes) ..... 21

3.12 ALDS Tank B Kit ..... 22

3.14 Tank Snorkel System ..... 23

3.15 Tank Controls ..... 23

3.16 Pilot/Co-Pilot Cyclic and Collective Controls ..... 24

3.17 Wiper Swipe .....25  
 3.18 Tank Displays .....25  
 3.19 Component Paint .....26  
 3.20 Antenna Relocation .....26  
 3.21 Scene Lights .....26  
 4 Qualification & Documentation .....26  
 5 Pricing .....27  
 6 Terms & Conditions .....27  
 7 Proposal Acceptance Page .....28

**Revision History**

The latest revision of this document is indicated by the highest revision number as listed below in the Revision History. All pages are revised when any page is changed so that all pages maintain the same revision level. A "List of Effective Pages" is therefore not included, but paragraphs are indicated. Changes to the current revision will be indicated within the document by change bars in the left margin.

Revision	Date	Description of Change
FFP-1	09/24/2020	Initial Release of Firm Fixed Price Proposal
FFP-2	11/2/2020	Updated proposal number and date Added Revision History Added notional dates to paragraph 1.9 Deleted note in paragraph 3.11 Deleted STC in paragraph 3.12 Updated cyclic and collective grip figures and description in paragraph 3.16 Clarified language in paragraphs 3.18, 3.19, and 3.20 Deleted note in paragraph 3.21 Updated Milestone Payments in paragraph 5 Changed paragraph 6 to reflect current status of Terms and Conditions Added United Rotorcraft signature block in paragraph 7

## Executive Summary

United Rotorcraft (UR), a Division of Air Methods Corporation (AMC) is providing this Firm-Fixed Price (FFP) Proposal to the Santa Barbara County Fire Department (SBCFD) with the information necessary to support budget planning and scheduling for the modification and testing of one Sikorsky Aircraft HH-60L Black Hawk conversion to the FIREHAWK® Helicopter.

**PROPOSAL VALIDITY PERIOD: 30 NOVEMBER 2020**

SBCFD has acquired one (1) U.S. Army surplus **HH-60L Black Hawk Air Ambulance** helicopter that requires conversion into an aerial firefighting helicopter similar to the configuration Sikorsky Aircraft and United Rotorcraft (UR) provided to LA County Fire in the past and more recently to other California based fire agencies. ***SBCFD purchased this helicopter and hired Arista Aviation (“Arista”) to provide maintenance inspections, some de-modifications of many different systems in the HH-60L, and installation of numerous avionics and other systems, on their aircraft prior to delivery to UR. This proposal assumes that the aircraft has been fully painted, and is ready for UR to proceed with the FIREHAWK Aerial Firefighting Mission Package modifications.***

***This proposal does not cover changes or maintenance UR might have to perform to install the FIREHAWK System and to accommodate the new systems installed by Arista for SBCFD.***

**This proposal is based on SBCFD contract award (estimated to be in 4Q20) before aircraft arrival in Colorado, and permit UR sufficient time to procure and produce all of the equipment necessary to modify the SBCFD HH-60L Black Hawk with the UR FIREHAWK systems.**

**This proposal covers ONLY the price and scope for the UR/KAWAK FIREHAWK Tank and High-Landing Gear Systems. Any additional scope and changes will be captured in a Contract Change Order (CCO) which would be reviewed and approved by both UR & SBCFD before any action is taken.**

This UR proposal provides a brief description of the equipment and systems to be installed by UR on the aircraft, our strategy for showing compliance of the modifications to the FAA Airworthiness Regulations, our methods for managing complex helicopter modifications, the pricing of major categories of systems, and the terms and conditions.

## 1 Aircraft Customization Programmatic Overview

The following descriptions of *key milestone* activities, processes and design review activities are provided in summary description as they would normally be expected to occur chronologically through each aircraft project plan.

### 1.1 Contract Award And Kick-Off Meeting

Upon contract award, a Program Manager (PM) will be assigned to your aircraft. The PM will schedule a Kick-off meeting (KOM) and System Requirements Review (SRR) at SBCFD to review the contract details and refine the Statement of Work (SOW). ***At this meeting schedule milestones for the aircraft completion will be defined.*** For the duration of the contract the dedicated PM will work with the SBCFD PM to provide schedule updates and coordinate aircraft completion activities. From the conclusion of the KOM through aircraft arrival the UR PM will provide monthly status reports on the aircraft schedule.

### 1.2 Program Management

Upon contract award, the Program Management Baseline (PMB) will be defined. An Integrated Master Plan (IMP) and a detailed Integrated Master Schedule (IMS) will be created to track all design, manufacturing and aircraft completion activity. These tools will be the basis of the program management performance measurements and controls that will be updated weekly to ensure the aircraft design and completion performs to the schedule.

After the KOM/SRR a risk assessment will be completed for each system and mitigation plans will be put in place. Subsequent risk assessments will be conducted throughout the design, certification, and completion of the aircraft.

After the KOM/SRR long leadtime procurement items will also be defined and purchase orders will be placed appropriately according to leadtime.

### 1.3 Aircraft Completion

Upon arrival in Englewood, CO, UR staff will conduct an aircraft induction process. A UR technician will complete a flight test with the SBCFD pilot, a mechanical inspection will be performed, and any incoming squawks will be documented. Loose equipment will be inventoried, the aircraft work order will be opened and the aircraft will be weighed. Throughout the process of opening the aircraft, the mechanics will note any items that require discussion or correction in the aircraft work order. The PM will work with SBCFD to agree on anything that requires disposition and track the corrective actions.

Throughout the aircraft completion the IMS will be updated weekly, documenting kit manufacturing and installation progress. This will be the basis of milestone reporting to SBCFD in the bi-weekly status reports.

UR will conduct a Mid-Point Review with the customer at the UR facility in Englewood, Colorado. As necessary, additional In-Process Reviews (IPR's) will be scheduled to facilitate design and certification discussions. At any point during the completion we welcome SBCFD to visit and review the aircraft progress.

#### **1.4 Change Orders**

The process for handling **Contract Change Orders (CCO's)** will be finalized in the KOM. When the need for new or reduced scope is identified, the UR PM will propose a solution with scope, schedule, and price (if applicable). SBCFD and the UR PM will work out the details of an acceptable solution and then the UR Program Manager will provide a signed CCO with scope, schedule and price. The CCO will be approved by SBCFD technical and financial representatives, and then UR will execute the change order and update program management documentation.

#### **1.5 Aircraft Close And Testing**

When all installations are complete and system check-outs have been performed the aircraft will be closed. A maintenance status report will be reviewed to ensure there are no open maintenance items that need to be completed before closing the aircraft. After the aircraft is closed the final weight and balance will be performed. The aircraft will then go through an extensive ground testing, functional testing, and flight testing. It is expected that this will take approximately two (2) weeks.

#### **1.6 Aircraft Delivery**

Following successful ground and flight testing, the aircraft will be moved to the delivery hangar and prepared for delivery. The delivery team will verify that all discrepancies noted in the induction process and in the WO are closed, and will complete a final mechanical and functional review of the aircraft. All loose equipment will be inventoried and displayed in the delivery hangar. Aircraft records will be reviewed and the documentation will be compiled in an electronic format agreed between PM and SBCFD.

When the aircraft is ready for delivery the PM will complete an inspection of the aircraft and all documentation prior to presentation to SBCFD. An acceptance data package will be prepared tailored to the SBCFD specific completion scope.



On the agreed delivery date, UR will present the aircraft to SBCFD for acceptance. The specifics of the delivery process will be agreed between SBCFD and PM, but will generally include the following:

- Review of closed induction or in-process discrepancies and corrective actions
- Mechanical inspection with panels open
- Aircraft records review
- Review of the deliverables in the SOW
- Demonstration of the functionality of all systems on the ground
- Demonstration of the performance of all systems in flight
- Review of loose equipment inventory

When SBCFD agrees that the aircraft complies with all delivery requirements, a customer acceptance form will be signed by both parties. At this time the final payment will be due and warranty period will begin.

#### **1.7 Airworthiness Demonstration Plan**

United Rotorcraft proposal includes the engineering documentation necessary to demonstrate the airworthiness compliance of the modified aircraft and the systems installed by UR. The basis for airworthiness compliance in the case of SBCFD HH-60L aircraft being modified into a FIREHAWK is the FAA 14 CFR Part 29 Design Regulations. This new FIREHAWK configuration requires the integration of numerous complex systems that must operate in the helicopter to perform the functions intended, as determined by the SBCFD team, and not interfere with other aircraft systems, while maintaining the airworthiness of the aircraft. We define Airworthiness as “the properties of a particular aircraft to safely attain, sustain, and terminate flight in accordance with the approved usage [*special mission*] and limits. (USFS FAM; *Special Mission Airworthiness Assurance Guide, Rev 1, DEC 7, 2011*)”.

This process ensures that SBCFD will receive their new FIREHAWK ready to operate and maintain in a safe and effective condition.

### **1.8 Quality Management System (QMS) (ISO 9001:2008 and AS9100C)**

The Standard for World Class Quality is ISO 9001 and AS9100. United Rotorcraft initially achieved ISO 9001 certification in July 2000. ISO 9001 is a system for establishing, documenting, and maintaining a system for ensuring the quality of the output of a process. In 2013 United Rotorcraft achieved initial AS 9100 certification the widely adopted and standardized quality management system for the aerospace industry. Re-certification to both of these standards was achieved in 2016 and is valid until 2018 (certificates available by request).

ISO 9001 and AS 9100 Certification is a tangible expression of United Rotorcraft's commitment to quality that is internationally understood and accepted. It is a group of common sense and generally well known precepts laid out in an organized fashion, consistent with our Vision, Mission, and Strategic Plan.

### **1.9 Integrated Master Schedule - TBD**

A *notional schedule* will be defined following contract award. There will be a unique schedule assigned following a kick-off meeting.

Scheduling assumes that all maintenance items are current and the aircraft is fully painted and ready for the FIREHAWK Aerial Firefighting Mission Package modifications.

Notional schedule dates:

- Contract Award 11/16/2020
- Aircraft Arrival 04/19/2021
- Aircraft Completion Acceptance 07/19/2021

### **1.10 SBCFD Provided Services**

The following list describes responsibilities and activities anticipated to be performed by SBCFD Team during UR's modifications of both aircraft:

- Flight Insurance for ground and flight testing.
- Fuel and aircraft operating costs during ground and flight test and transporting aircraft to and from UR facility.
- Aircraft Documentation at aircraft induction to UR.
- Maintenance (all aircraft)
  - From induction through delivery at UR Englewood, CO
- Pilot Support (all aircraft)
  - Induction flight to UR in Englewood, CO
  - Post installation flight test
- Flight testing (first article only)
  - SBCFD pilot responsibilities will be clarified after flight test requirements have been defined
  - UR will provide a flight test pilot to execute PIC duties when required
  - Testing will be much more extensive with new design
  - Ground test support
  - Flight test support
- Program Management / Technical Support

## **2 Cabin Interior**

SBCFD requested to review the various seating options available in the FIREHAWK with UR. **This section currently has no scope or pricing, but is retained as a placeholder for further conversation and decisions.**

### **2.1 Crew Seating**

- TBD

### **2.2 Floor Pallets**

- TBD

### **2.3 Supply Storage Box**

- TBD

### **2.4 Aft Cabin Stowage Compartments**

- TBD

### **2.5 Cabin Miscellaneous Components**

- TBD

### 3 Aerial Firefighting Mission Package (AFMP)

This FFP proposal statement of work describes the deliverables supporting the modification and delivery of the SBCFD HH-60L Helicopter with the United Rotorcraft (UR) FIREHAWK® Tank and High Landing Gear (HLG) systems and modifications.

The primary FIREHAWK® conversions include the addition of provisions for a Kawak (KATI) 1000 gallon water tank mounted to the belly of the aircraft, and the UR main landing gear extension (known as the High Landing Gear, HLG) modification to accommodate the water tank installation.

These provisions allow the HH-60L to be operated at its MGW with equipment attached to these new mounts and the new HLG extension system. The aircraft operating performance has been tested and documented in the UR RFMS and other documents, and will be provided with the completion of the SBCFD FIREHAWK.

This document provides the description of the Tank and HLG modification related to the HH-60L FIREHAWK® helicopter. The modifications include:

- High Landing Gear "A" Kit  
Items primarily fixed to the aircraft including hard mounting points for extending the main landing gear (raises aircraft 20") as well as steps and handholds to help pilots and crew access the elevated aircraft.
- High Landing Gear "B" Kit  
Items that make up the remaining HLG including structural extension, Weight on Wheels harness extensions, brake line extensions and stub wing fairing modifications.
- Tank "A" Kit  
Items primarily fixed to the aircraft including four Tank mounting provisions, belly electrical connectors and electrical modifications within the aircraft to accommodate the Tank and associated power and controls.
- Tank "B" Kit  
This includes the primary Tank assembly (water tank, foam tank, retractable snorkel, steps/platforms, wire harness, etc.) and components related to pilot control and displays.

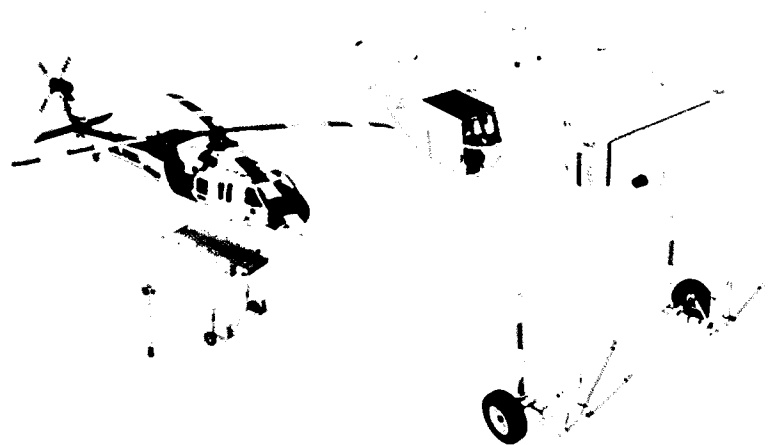

### 3.1 High Landing Gear

United Rotorcraft will provide our exclusive High Landing Gear (HLG) system, which provides a **20 inch vertical lift** to the HH-60L using the existing landing gear strut and wheel system, and will allow the new **FIREHAWK Aerial Liquid Dispensing System (ALDS)** to be installed on this Black Hawk helicopter. The gear system will limit the aircraft performance as identified in the UR RFMS. The aircraft can be operated with the High Landing Gear system but with the ALDS Tank removed.

The aircraft weight & balance charts are updated in the RFMS and existing CG limits for all flight regimes with / without tank installed through loaded tank operations.

### 3.2 High Landing Gear (HLG) A-B Kits

In order for the 1000 gallon tank to fit under the aircraft, the main landing gear is extended so the aircraft has additional clearance on the underside. The main gear (wheels, shock struts and drag beams) are removed. New landing gear attachment points are installed that are 20 inches lower than the original attachment points, and the main landing gear is then re-installed raising the aircraft 20" off the ground.

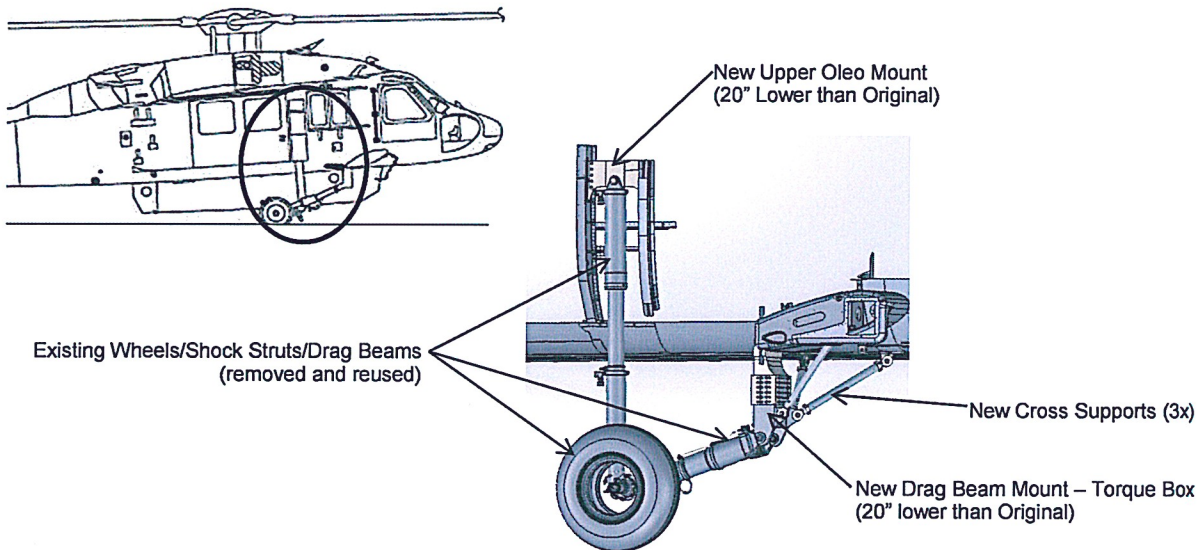

### 3.3 HLG A Kit (Main Landing Gear)

The HLG A-Kit primarily consists of the new upper oleo mounting provisions and two of the torque box cross support attachment structure as shown. Also part of the A-Kit modifications in the main landing gear area are two stub wing structural trims to allow new parts to mate properly to the aircraft. The aircraft new on-ground static position is now nose-high, a new single drain hole is added to properly drain fluids in the upper tail section.

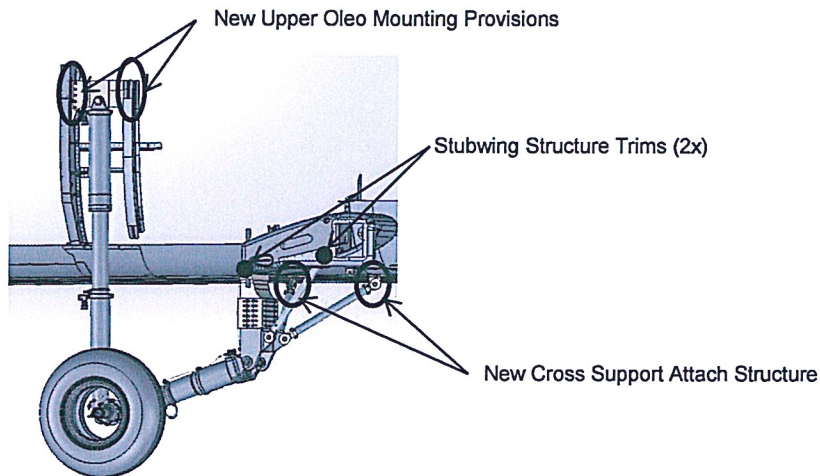

### 3.4 HLG A Kit (Steps)

There is an existing maintenance step (L/H and R/H side) that normally folds and stows into the aircraft frame when not in use. The new upper oleo mounting provisions interferes with the stowage of this step, so the step is modified to be removable when not in use.

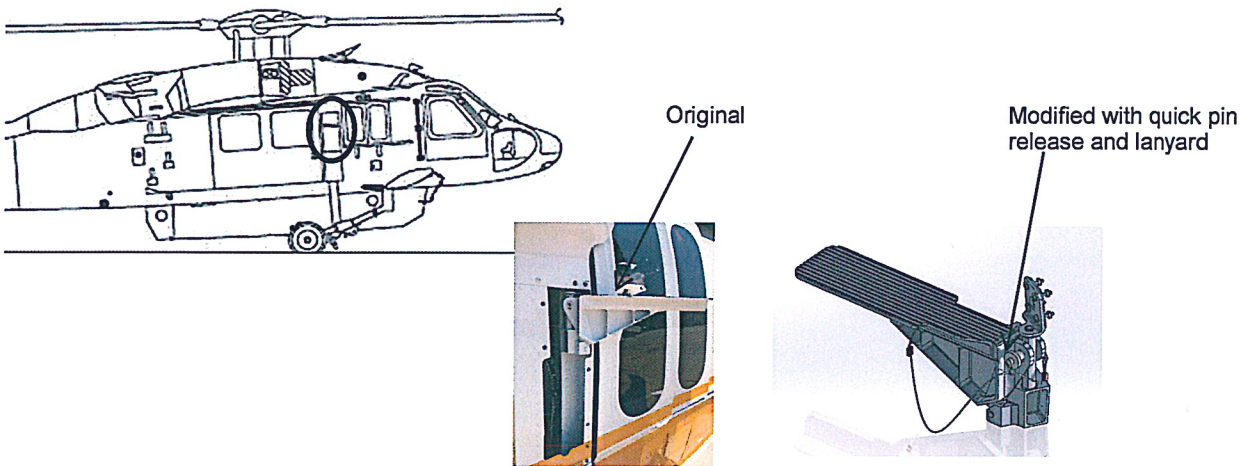

### 3.5 HLG A Kit (Handholds)

Due to the increased height of the aircraft, there are six new handles installed that assist the pilots and crew to enter and exit the aircraft.

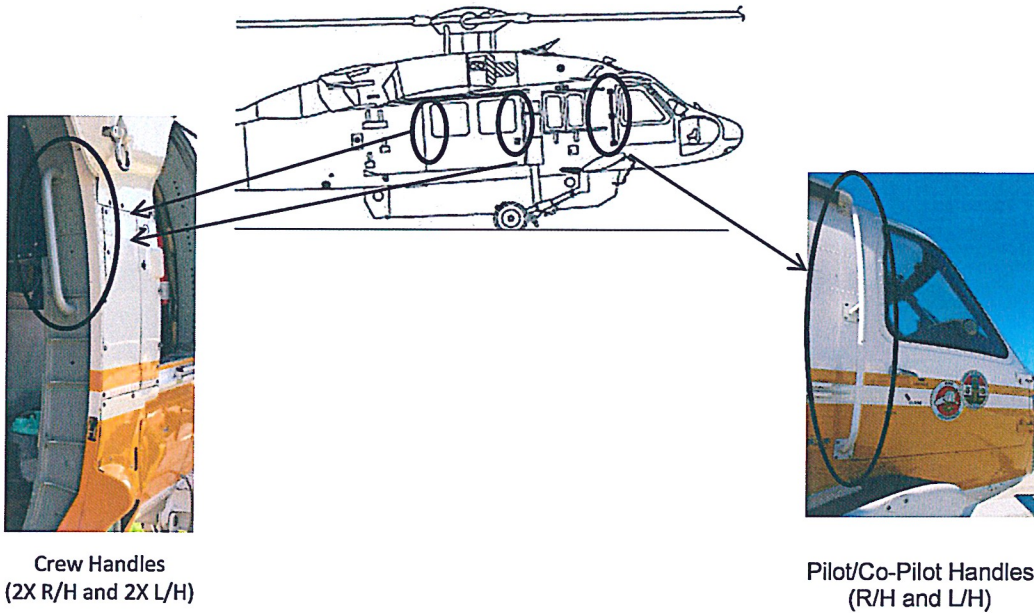



### 3.6 HLG B Kit (Main Landing Gear)

The HLG B Kit primarily consists of the new upper oleo mounting plate and the torque box with three cross supports.

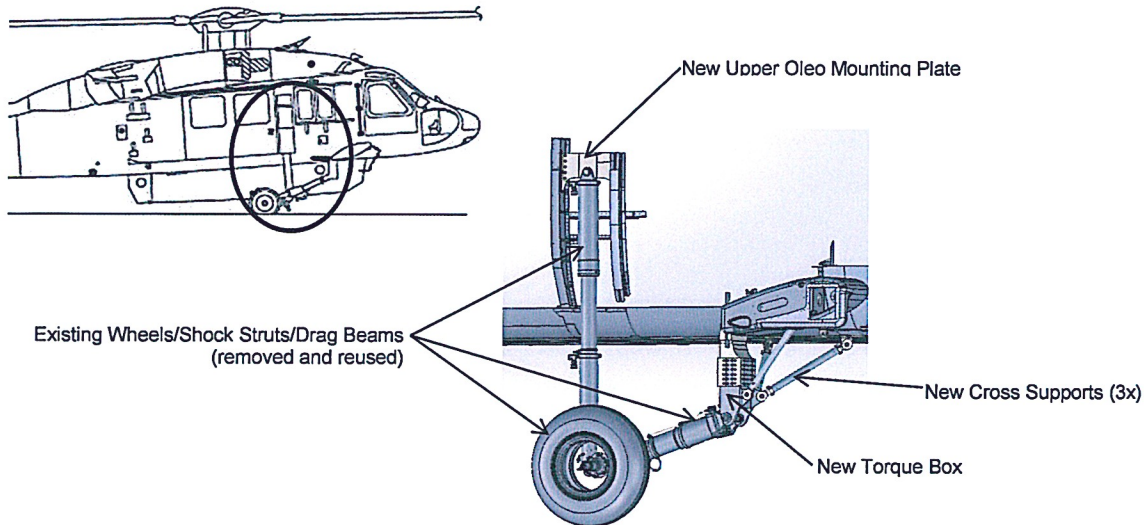

### 3.7 HLG B Kit (Steps and Stubwing Fairings)

There are steps added to the fwd and aft end of the stubwing to assist the pilots and crew. A new Aft Stubwing Crew Step is mounted on the aft end of the stubwing fairing. This step aids the crew in accessing the upper deck of the aircraft and is also used when crewmembers enter or exit through the gunners window. A new Pilot/Co-Pilot Step is mounted on the fwd end of the stubwing to assist the pilots when entering or exiting the aircraft. This step also functions as a guide for the existing wire strike system and will direct a wire to the cutter located on the landing gear drag beam.

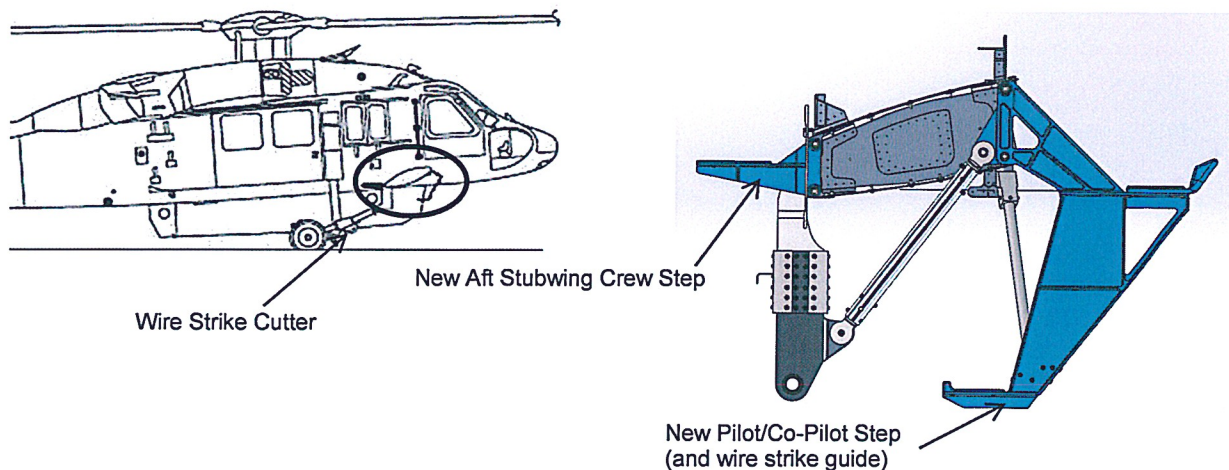

The addition of the two stubwing steps requires a modification to the stubwing fairings. Two areas of the stubwing fairing are removed to allow proper clearance for the step attachment structure.

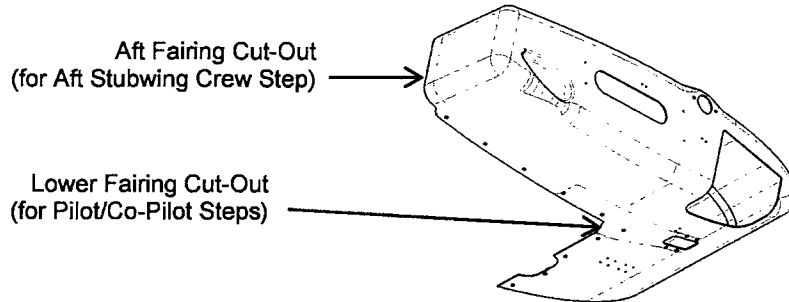

### 3.8 HLG B Kit (Other)

With the extended landing gear installed, several other systems are affected and modified as follows:

- a) The **WOW (Weight on Wheels)** harness and **brake lines** are extended to accommodate the 20" height increase.

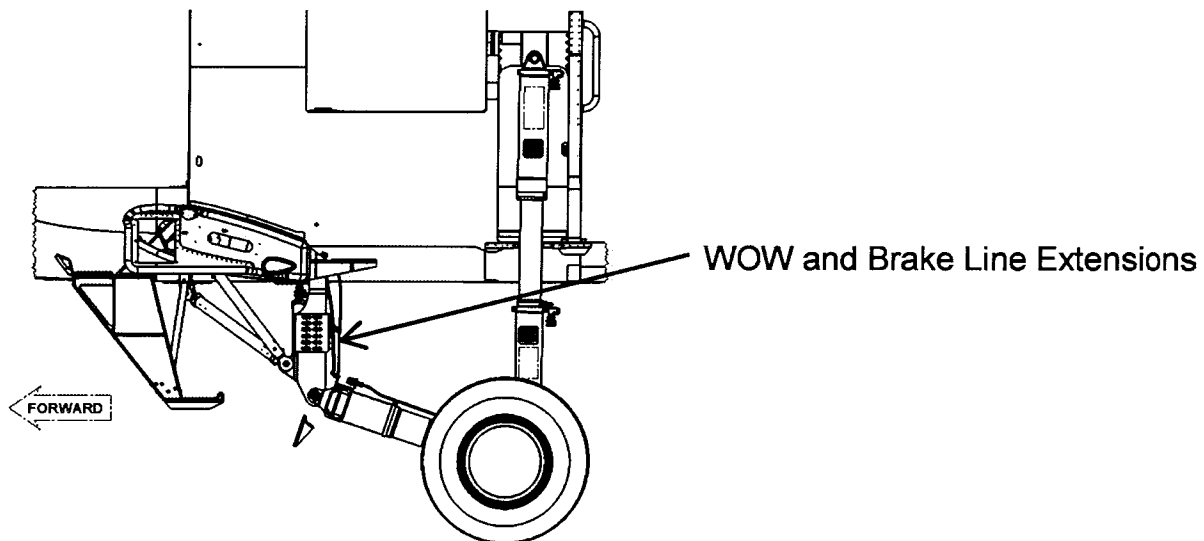

b) The aircraft sits on the ground with the nose up 3.6 degrees. In this configuration three gearbox oil level indicators are adjusted accordingly. The main transmission dip stick is etched with new Add/Full markings.

### HLG B Kit Main Transmission Dip Stick Modification

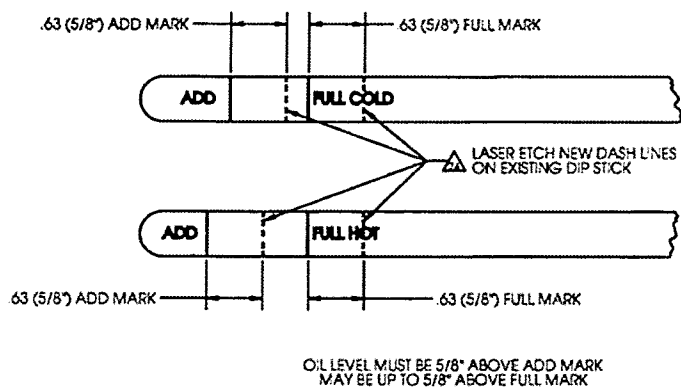

And the intermediate gearbox and tail gearbox site glasses receive new placards indicating proper oil levels in the HLG configuration.

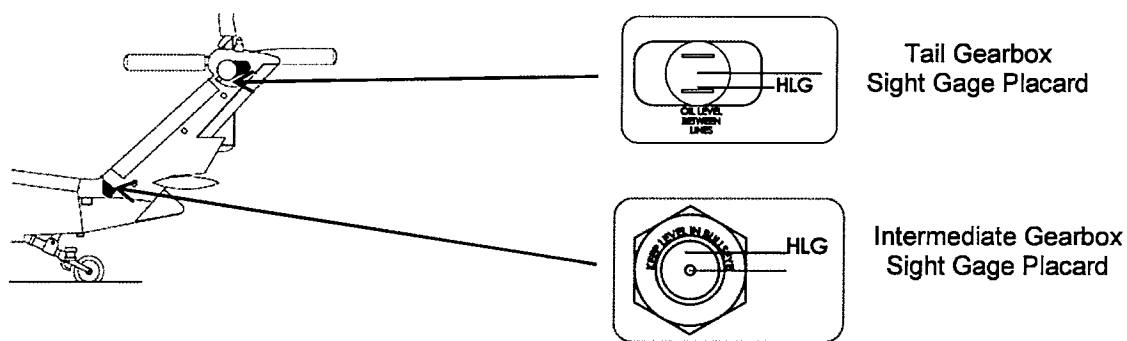

c) In order to maintain a minimum 3 ½" ground clearance with the tank doors open and the aircraft fully loaded the shock strut pressures are increased and placards are added as follows. The higher strut pressures require a decreased life limit (from 8000 hrs to 6000 hrs) for both the main struts and tail struts.

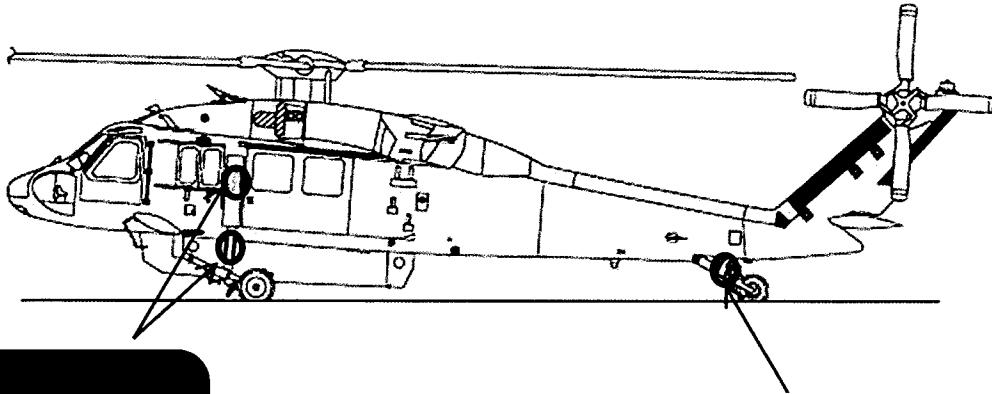

Main Shock Strut  
Servicing Placard

Tail Shock Strut  
Servicing Placard

### **3.9 Aerial Liquid Dispensing System (ALDS) - Water Tank**

The UR & Kawak Aviation, ALDS includes a 1000 gallon water tank made from aluminum frame and sheet metal skin installed on the belly of the aircraft. The snorkel is on the right side of the tank and aircraft. The UR supplier of the tank will be Kawak Aviation Technologies (KATI). The ground clearance to the tank is approximately six (6) inches or greater at any point over level terrain with the aircraft at 22,000 pounds gross weight, and with tank-doors closed, and at least 1.75 inches with tank doors open.

The ALDS tank is capable of being ground filled simultaneously from both sides of the tank utilizing either gravity or pressurized water sources. These fill points do not interfere with the tank mounting or removal. The tank quantity sight gauges on the left and right sides of the main tank are replaceable if damaged or dirty.

The water and foam systems include appropriate venting to ensure rapid water/foam release with no pulsing effects or negative pressure created in the tanks.

During water drop operations, the ALDS is capable of maintaining a constant dispersal pattern that meets USFS requirements and industry standards. The tank doors are mechanically adjustable to ensure proper alignment and minimize leakage.

Steps are attached to the tank on both sides of the aircraft for the full length of the cargo door openings. Additional steps on both left and right sides are included for cabin ingress and egress.

UR manufactures and installs the ALDS Tank mounting provisions on the belly of the aircraft. These provisions include 4 mounting lugs as well as two (2) electrical plugs (power and control system) on the RH forward side of the aircraft.

The ALDS tank installation & removal system is designed to utilize minimum maintenance personnel for either install or removal.

#### **3.10 Tank A Kit Mechanical**

The Tank A Mechanical system consists of five (5) individual installations as follows.

There are four (4) main water tank mounting lug installations that attach permanently to the underside of the aircraft. These installs include all the internal supporting structure and hardware required for each of the four mounting lugs. The four installs are 819-1122-001/-002 (FWD Tank Attachments) and 819-1123-001/-002 (AFT Tank Attachments).

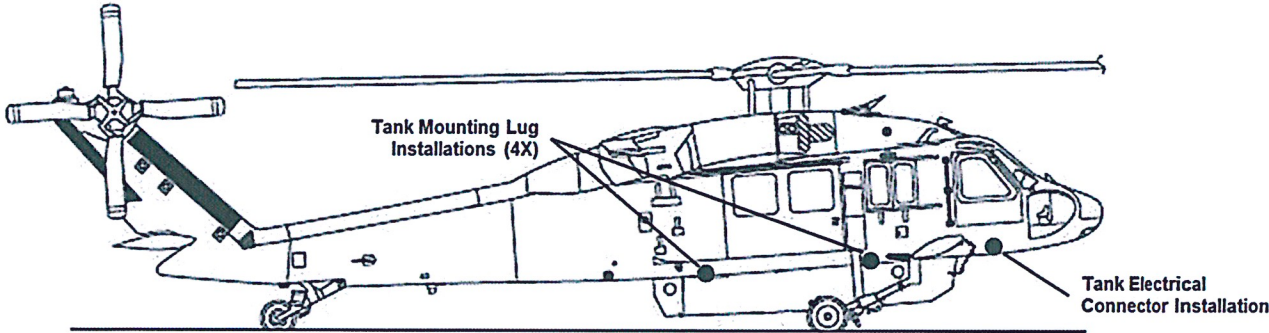

The pictures below show the four (4) Tank Mounting installations.

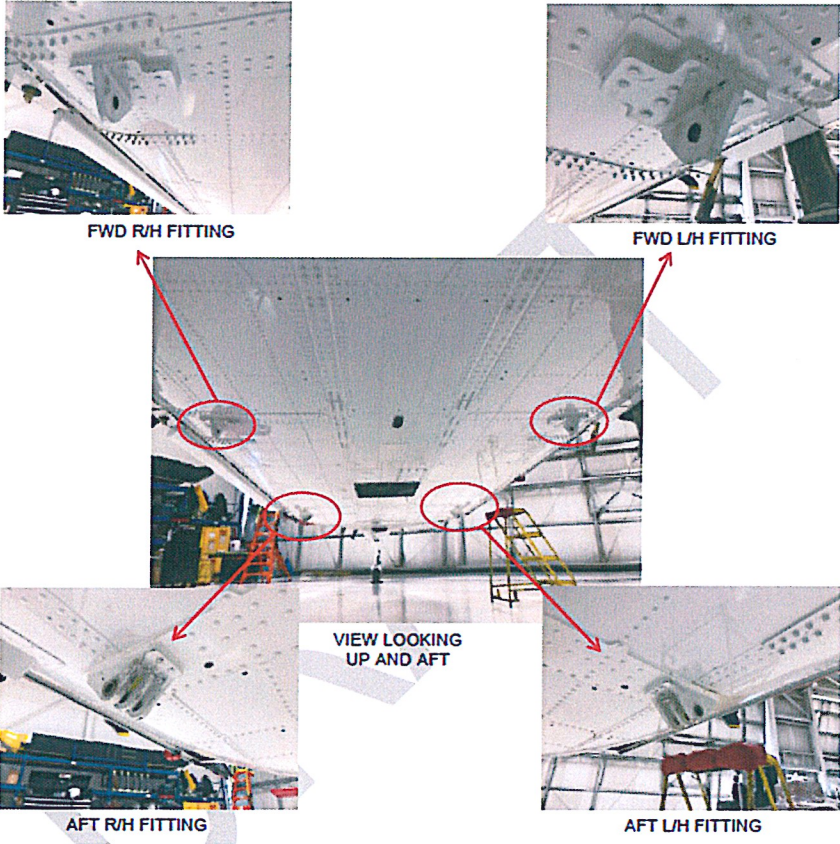

These new installations have been designed and analyzed to accommodate the HH-60L dimensional and structural requirements and also incorporates the new water tank empty weight and mass properties.

UR has taken these new designs into consideration as the new hardware has also been reinvented for the UH and HH-60L helicopters.

Custom fixture tooling has been developed to assure consistent tank mating and tank interchangeability between all FIREHAWK® aircraft.

### 3.11 Tank B Kit (Drain Tubes)

The installation of the tank assembly requires the rerouting of various aircraft drain tubes. The installation drawing for the drain tubes is 819-1002-004 (Drain Tube Install).

This installation could be modified to support extending these drain tubes past any rack or cabin step fixture the customer may use under their aircraft with the UR FIREHAWK® HLG and Belly Mounts.

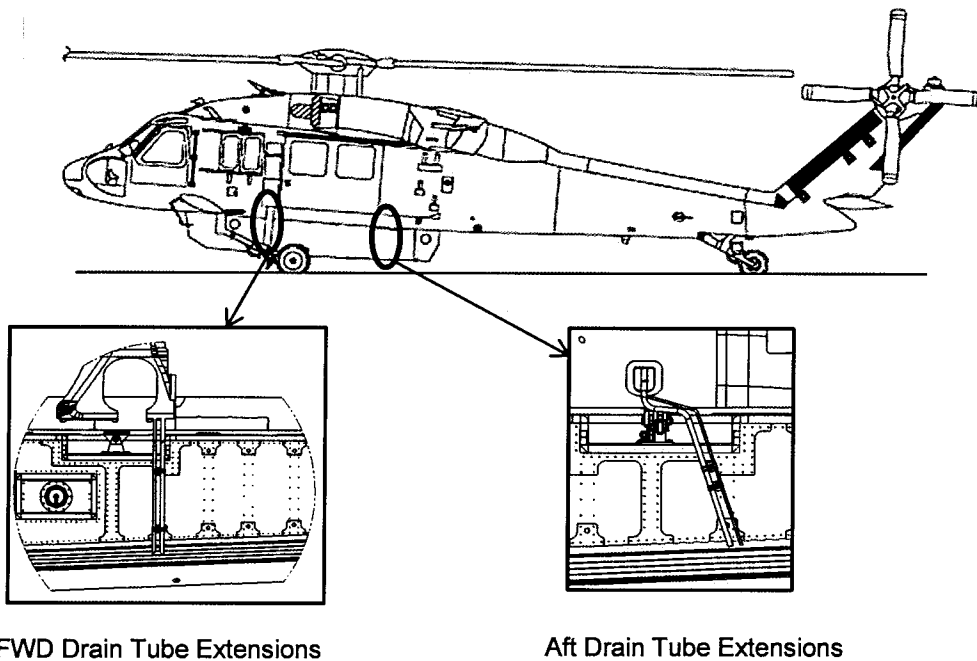

FWD Drain Tube Extensions

Aft Drain Tube Extensions

### 3.12 ALDS Tank B Kit

The primary Tank B Kit component is the Aerial Liquid Dispensing System (ALDS) tank assembly that mounts to the belly of the aircraft. This tank assembly has been designed and manufactured by Kawak Aviation for UR FIREHAWK. Detailed information for this tank assembly will be supplied by Kawak for this program. The installation drawing for the main tank assy is 819-1002 (Tank B-Kit Water Tank Installation).

The primary components of this assembly are as follows.

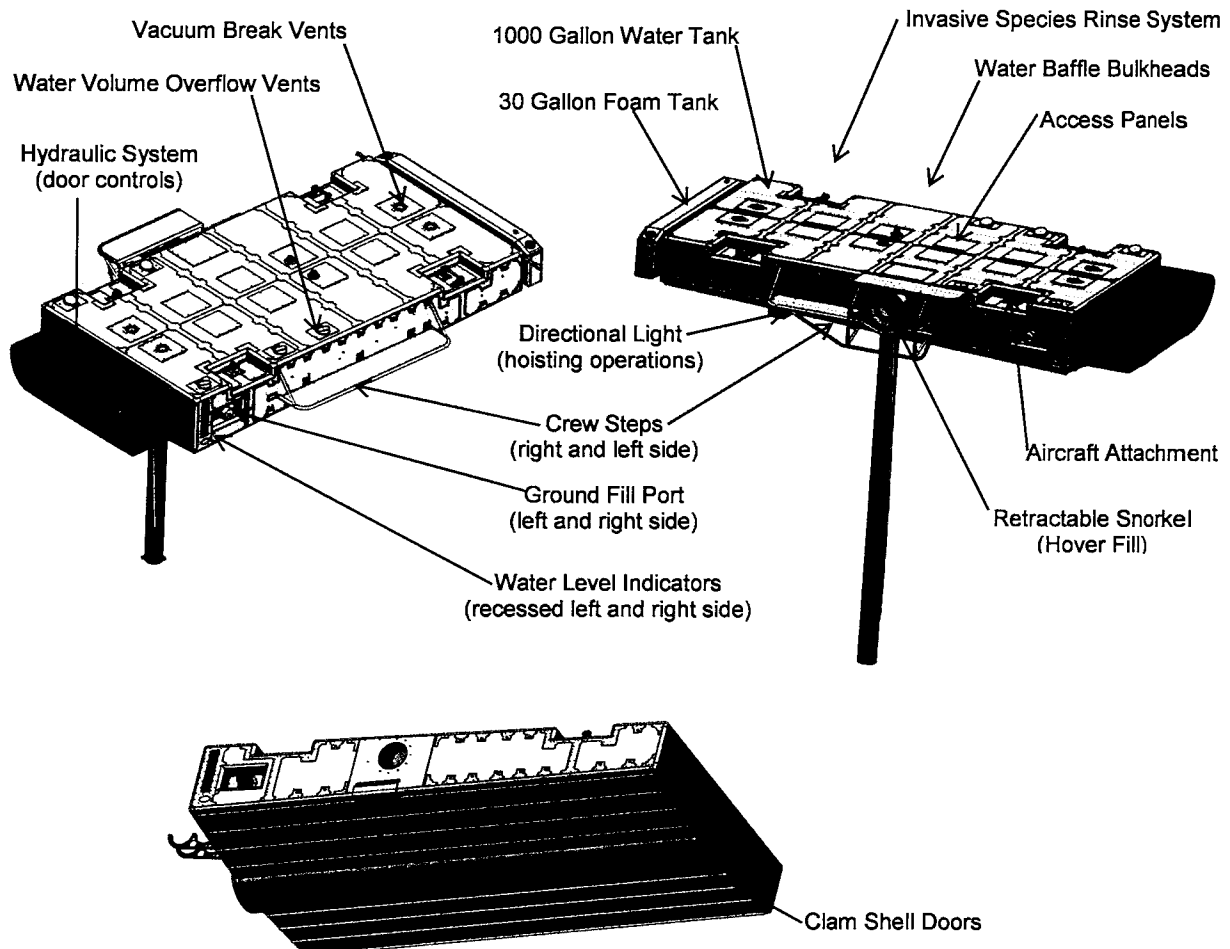



### 3.13 Foam Tank

As an integral part of the main water tank, a 30 gallon Foam Retardant Tank is integrated to the aft end of the water tank. The tank is an aluminum frame and sheet metal. The foam tank is fillable from left and right side fill-ports, as well as being drainable.

### 3.14 Tank Snorkel System

The retractable snorkel system consists of a sock approximately ten (10) feet in length, a high capacity 7.5 HP pump at the end of the sock and a reel that deploys and recovers the sock and pump (collectively known as the snorkel). The snorkel is capable of filling the 1000 gallon tank in 60 seconds or less when the snorkel is fully extended and the pump is at minimum water depth for operation.

The snorkel system is designed in a modular fashion to support maintainability with guards designed into the hose reel to ensure proper alignment of hose onto the rotating drum.

### 3.15 Tank Controls

All tank controls will be reviewed and configuration approved during design review by SBCFD, but before modification of the Cyclic and Collective and aircraft systems.

UR integrates the ALDS controls and display into the aircraft:

- ALDS Main control unit is mounted in the pedestal.
- Main Control panel includes a Foam control switch and injection.
- Water/Foam Drop Selector will select Volume of Water relative to the amount of water remaining in the tank.
- Water/Foam Drop Selector will select Full Load coverage levels to be selectable in gallons per 100 square feet (gpc) from 1/2 to 8.

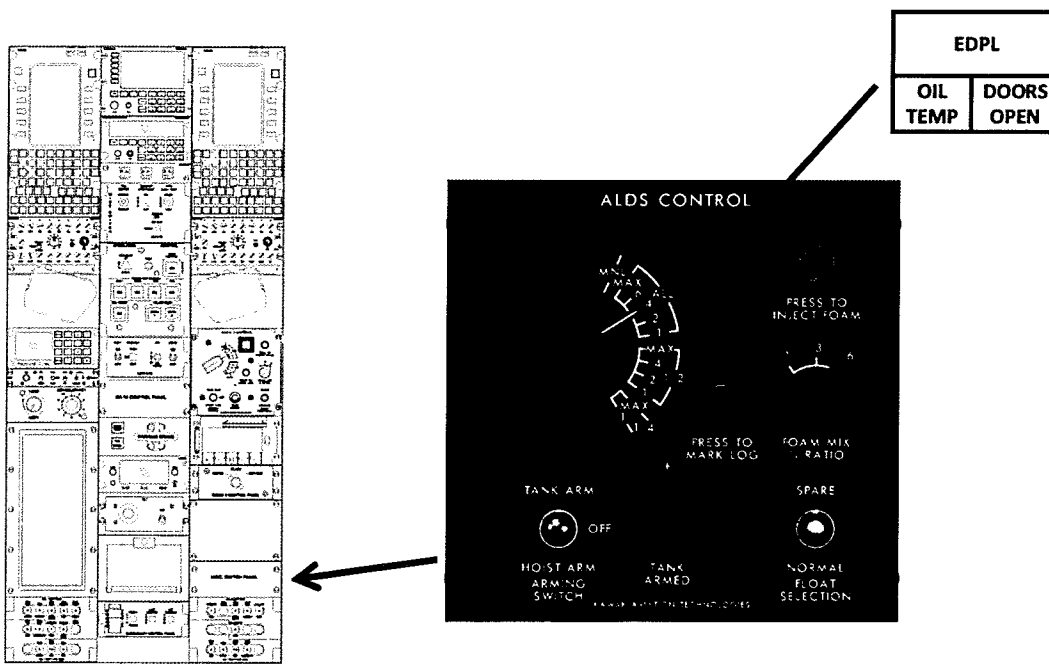

### 3.16 Pilot/Co-Pilot Cyclic and Collective Controls

The UR Aerial Firefighting Mission Package (AFMP) includes modifying both the Pilot and Co-Pilot cyclics and collectives, per customer requirements, SBCFD configuration may need to be changed to support differences in the equipment installed or mission profile. UR PM will review the as-is configuration of the SBCFD HH-60L with SBCFD staff to determine if out-of-scope changes need to be made to the existing Cyclic or Collective Controls to complete the install of the FIREHAWK equipment.

Left and right seat pilot controls will be installed such that they support all modes of operation including emergency dump.

- Ⓐ Normal Dump switch Tank Door Open Switch (multi purposed with the Cargo Release Switch)
- Ⓑ Emergency Release Switch (Tank E-Dump, Cargo Hook)
- Ⓒ Snorkel Up/Down Switch
- Ⓓ Wiper Swipe Switch
- Ⓔ Snorkel Pump Switch

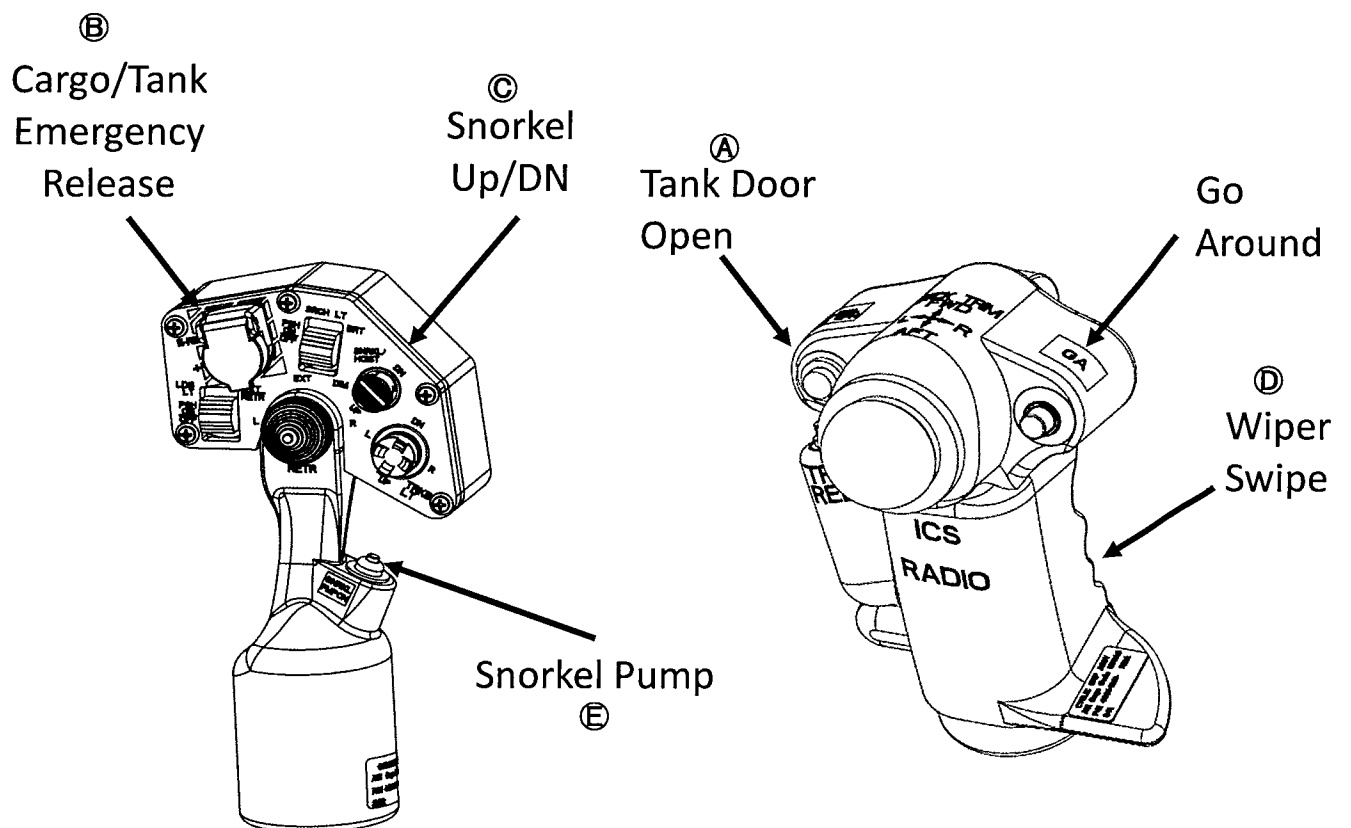

### 3.17 Wiper Swipe

UR integrates a new switch on the Cyclic to operate the windshield wiper during Snorkel fill.

### 3.18 Tank Displays

The ALDS tank display is **MacroBlue** MB-Q Series vertical 7" LCD display, NVIS compatible display, that will show Water/Foam tank information. **The new display is designed to be mounted on right (shown in pictures below) of instrument panel in clear view of pilot.** A second optional co-pilot display can be located on the left side of the instrument panel. The displays can be folded back out of site when not in use.

**NOTE: THIS INSTALLATION WILL BE EVALUATED TO DETERMINE IF THE SBCFD HH-60L HAS THE SPACE TO SUPPORT THE INSTALLATION OF THIS DISPLAY IN THIS LOCATION.**

A wide variety of tank status data can be displayed and the dual knob controller can select up to eight (8) display configurations. The tank control system will accurately depict water/foam levels selectable to gallons and/or pounds, coverage level selected, foam injection level selected, tank door position and system arming status.

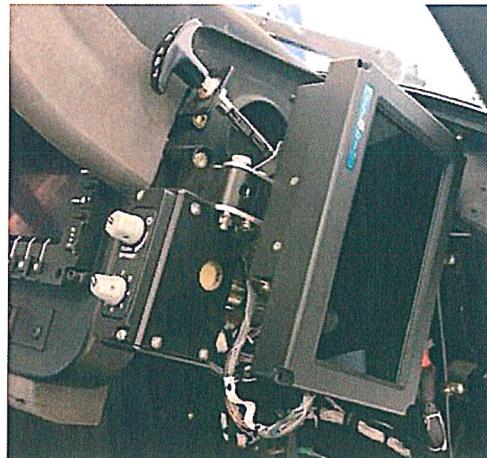

The primary information that is displayed is:

- a) Water tank volume in pounds or gallons (1000 gallon max)
- b) Foam tank volume in pounds or gallons (30 gallon max)
- c) Retractable snorkel position indicator
- d) Annunciators for various system functions
- e) Current foam concentration in water tank
- f) Pilot control panel selection status

### **3.19 Component Paint**

United Rotorcraft will coordinate with customer on the specification and requirements for new components paint. Tank will be painted white.

### **3.20 Antenna Relocation**

United Rotorcraft relocates the antennas from the belly of the aircraft to more forward positions to support their systems continued operation with the installation of the Water Tank on the FIREHAWK® belly. UR will relocate the Marker Beacon antenna, and the ADF antenna, if installed on the belly.

**NOTE: UR will coordinate with the SBCFD to determine if this modification is required for their aircraft.**

### **3.21 Scene Lights**

United Rotorcraft will install **Scene Lights** mounted below the crew windows to illuminate the area which augments operations around the main landing gear, steps for crew window and pilot steps. The lights are LED and controls are mounted overhead in the cockpit (ON/OFF).

## **4 Qualification & Documentation**

UR will provide documentation to describe and support the equipment and modifications installed on the SBCFD FIREHAWK, which is also the foundation for the airworthiness of the modified aircraft. These will include Instructions for Continued Airworthiness (ICA), which includes system drawings and instructions for all stand-alone components, and a Rotorcraft Flight Manual Supplement (RFMS).

## 5 Pricing

This Firm-Fixed Pricing is for the scope described in this document, GP18-024\_FFP-2, for the modification of one (1) HH-60L Black Hawk helicopter: \$2,495,000

PROPOSAL VALIDITY PERIOD: 30 NOVEMBER 2020

The following table contains the proposed Milestone Payment Plan:

MILESTONE PAYMENTS	
CONTRACT AWARD	40%
AIRCRAFT INDUCTION IN ENGLEWOOD, CO	30%
AIRCRAFT DELIVERY/ CUSTOMER ACCEPTANCE	30%

## 6 Terms & Conditions

Santa Barbara County Fire and United Rotorcraft have successfully negotiated the Terms and Conditions.

**7 Proposal Acceptance Page**

**Air Methods Corporation, United Rotorcraft Division**

**FIREHAWK Proposal – FFP**

**Point of Contact:**

**MAILING ADDRESS:**

**ATTENTION: LARRY ALEXANDRE**

**7301 SOUTH PEORIA**

**ENGLEWOOD, CO. 80112**

**E-MAIL: [larry.alexandre@airmethods.com](mailto:larry.alexandre@airmethods.com).**

**PHONE: (303) 256-4185**

  
\_\_\_\_\_  
**LARRY ALEXANDRE, PRESIDENT UNITED ROTORCRAFT, AN AIR METHODS DIVISION**

THE SIGNATURE ON THIS ACCEPTANCE PAGE INDICATES RECEIPT AND ACCEPTANCE OF THIS PROPOSAL, THE NOTIONAL PROJECT SCHEDULE (UPDATED FIRM SCHEDULE TO BE PROVIDED AFTER CONTRACT AWARD), THE NEGOTIATED TERMS AND CONDITIONS, AND THE PRICING AND PAYMENT SCHEDULE PROVIDED WITH THIS PROPOSAL.

**AUTHORIZED BY SANTA BARBARA COUNTY FIRE  
APPROVAL NAME & SIGNATURE:**

**NAME:** Bregg Hart, Chair, Board of Supervisors

**SIGNATURE:** 

**DATE:** 11-17-2020

**SANTA BARBARA COUNTY FIRE:** Mark Hartwig, Fire Chief

**ADDRESS:** 4410 Cathedral Oaks Rd. Santa Barbara, CA 93110

**CONTACT INFORMATION:** mark.hartwig@sbcfire.com (805) 681-5500

**GENERAL TERMS AND CONDITIONS  
FOR AIRCRAFT MODIFICATIONS AND MAINTENANCE**

1. **APPLICABILITY:** These general terms and conditions (these "Terms") govern the sale of the goods and services (the "Deliverables") by United Rotorcraft, a division of Air Methods Corporation, a Delaware corporation ("Seller") to Santa Barbara County Fire Department ("Buyer"). Buyer and Seller are referred to individually herein as a "Party" and together as the "Parties". Notwithstanding anything herein to the contrary, to the extent there are any inconsistencies between these Terms and the terms contained in the Agreement for United Rotorcraft Fixed-Belly Tank and Lift Conversion entered into by the Parties to which these Terms are attached, these Terms shall prevail. These terms and any such contract and any accompanying invoice or statement of work delivered by Seller to Buyer (collectively, this "Agreement") comprise the entire agreement between the Parties, and supersede all prior or contemporaneous understandings, agreements, negotiations, representations and warranties, and communications, both written and oral. None of Buyer's purchase order prices, terms and conditions, or delivery schedule shall be binding upon Seller, and Seller hereby objects to same, unless and until accepted in a writing signed by an authorized representative of Seller. Fulfillment of Buyer's order does not constitute acceptance of any of Buyer's terms and conditions and does not serve to modify or amend these Terms.

2. **AIRCRAFT ACCEPTANCE BY SELLER:** As the Deliverables include modifications or maintenance to the Buyer's aircraft, upon receipt of the aircraft Seller will conduct an airframe and systems configuration analysis and take inventory of all loose items. Any mutually agreed upon changes that must be made to the aircraft or the installations provided by Seller due to aircraft condition, previous modifications or structural issues will be charged in addition to the price quoted after review and acceptance by Seller and Buyer of the additional pricing. Upon receipt of aircraft, Seller will conduct an inspection with the Buyer present to identify items/issues for which additional charges will apply. Transport costs of the aircraft to and from Seller's facility are the responsibility of the Buyer.

3. **EXPIRATION OF OFFER:** All offers of sale by Seller or its authorized representatives are firm for thirty (30) days from the date of offer (unless the offer specifically states a different period of validity) and are subject to change without prior notice after such period.

4. **CHANGE ORDERS:** The prices quoted in the statement of work ("SOW") and agreed by the Parties are expressly for the Deliverables and delivery schedule agreed upon in writing. If Buyer desires to make changes to the Deliverables or delivery schedule (including any cessation or interruption of the work), the Parties must first negotiate a change order and agree in writing upon an appropriate price and/or schedule adjustment before the change will be considered effective. A temporary cessation or interruption requested by Buyer in writing of no more than twenty (20) days shall not constitute a breach of this Agreement

5. **PRICE:** Buyer shall purchase the Deliverables from Seller at the price (the "Price") set forth in the SOW executed by the Parties under this Agreement. All Prices are exclusive of all sales, use and excise taxes, and any other similar taxes, duties and charges of any kind imposed by any governmental authority on any amounts payable by Buyer. Buyer shall be responsible for all such charges, costs and taxes; *provided*, however, that Buyer shall not be responsible for any taxes imposed on, or with respect to, Seller's income, revenues, gross receipts, personnel, or real or personal property or other assets.

6. **PAYMENT TERMS:** Buyer shall pay all invoiced amounts due to Seller within thirty (30) days from the date of Seller's invoice. Buyer shall make all payments hereunder by check or wire transfer in US dollars. Buyer shall pay interest on all late payments at the lesser of the rate of 1.5% per month. Buyer shall reimburse Seller for all costs incurred in collecting any late payments, including, without limitation, attorneys' fees. In addition to all other remedies available under these Terms or at law (which Seller does not waive by the exercise of any rights hereunder), Seller shall be entitled to suspend the delivery of any Deliverables if Buyer fails to pay any amounts when due hereunder and such failure continues for five (5) days following written notice thereof. Upon payment of any overdue amounts, Seller shall resume delivery. Buyer shall not withhold payment of any amounts due and payable by reason of any set-off of any claim or dispute with Seller, whether relating to Seller's breach, bankruptcy, or otherwise.

7. **DISPUTE RESOLUTION:** All claims, disputes and/or controversies arising out of or in relation to the performance, interpretation, application, or enforcement of this Agreement, including but not limited to breach thereof, shall follow the following procedure. First, either Party may request a peer-to-peer review to resolve any issues or disputes. Upon request of a peer-to-peer review by either Party, both Parties shall make available an appropriate individual with appropriate credentials for a telephone call or other communication within fifteen (15) days of the request. With respect to issues for which the peer-to-peer review process has been exhausted, either Party may request a meeting to resolve the issue. Within forty-five (45) days of such request, senior position delegates from Buyer and Seller shall meet in a good faith effort to resolve the dispute. If the Parties are unable to resolve the dispute pursuant to the peer-to-peer review process or a good faith meeting, the Parties agree to submit all disputes for mediation with a neutral third party mutually agreed upon by the Parties. Such mediation shall take place within sixty (60) days of such request. Lastly, if the Parties are unable to resolve the dispute through peer-to-peer review, a good faith meeting, or mediation, then either Party may file a legal action in an appropriate forum.

8. **DELIVERY:**

- (a) The Deliverables will be delivered as provided in the mutually agreed upon delivery schedule. Seller is not liable for any loss or damages to the Deliverables or Buyer's aircraft while in transit to or from Seller's

facility, except to the extent any loss or damages are caused by Seller's negligence or breach of these Terms.

- (b) Unless otherwise agreed in writing by the Parties, Seller shall deliver the Deliverables F.O.B. Seller's facility in Englewood, Colorado, U.S.A. (the "Delivery Point"), using Seller's standard methods for packaging and shipping such Deliverables. Buyer shall take delivery of the Deliverables within thirty (30) days of Seller's written notice that the Deliverables have been delivered to the Delivery Point. Buyer shall be responsible for all loading and transport costs and provide equipment and labor reasonably suited for receipt of the Deliverables at the Delivery Point and transport therefrom.
- (c) Seller may, upon mutual agreement of the parties, without liability or penalty, make partial shipments of loose or spare equipment to Buyer.
- (d) If for any reason Buyer fails to accept delivery of any of the Deliverables on the date fixed pursuant to Seller's notice that the Goods have been delivered at the Delivery Point, or if Seller is unable to deliver the Deliverables at the Delivery Point on such date because Buyer has not provided appropriate instructions, documents, licenses or authorizations: (i) risk of loss to the Deliverables shall pass to Buyer; (ii) the Deliverables shall be deemed to have been delivered; and (iii) Seller, at its option, may store the Deliverables until Buyer takes physical possession of them, whereupon Buyer shall be liable for all related costs and expenses (including, without limitation, storage and insurance). Notwithstanding the foregoing, Seller shall not be held responsible for Deliverables left at the Delivery Point more than thirty (30) days after delivery of such Deliverables, unless otherwise agreed to in writing by the Parties.

9. **NON-DELIVERY:** Any liability of Seller for non-delivery of any loose or spare equipment shall be limited to replacing such equipment within a reasonable time or adjusting the invoice respecting such equipment to reflect the actual quantity delivered.

10. **TITLE AND RISK OF LOSS:** Title and risk of loss to the Deliverables passes to Buyer upon delivery of the Deliverables at the Delivery Point. As collateral security for the payment of the purchase price of the Deliverables, Buyer hereby grants to Seller a lien on and security interest in and to all of the right, title, and interest of Buyer in, to, and under the Deliverables, but not the Blackhawk itself, wherever located, and whether now existing or hereafter arising or acquired from time to time, and in all accessions thereto and replacements or modifications thereof, as well as all proceeds (including insurance proceeds) of the foregoing. The security interest granted under this provision constitutes a purchase money security interest under the Colorado Uniform Commercial Code. Upon complete payment of the purchase price of the Deliverables, any such lien will expire.

11. **INSPECTION AND REJECTION OF NONCONFORMING GOODS:**

- (a) Buyer shall inspect the Deliverables within ten (10) days of receipt (the "Inspection Period"). Buyer will be deemed to have accepted the Deliverables unless it notifies Seller in writing of any Nonconforming Goods (as defined below) during the Inspection Period and furnishes such written evidence or other documentation as reasonably requested by Seller. Notwithstanding Buyer's rights under Section 13 below, "Nonconforming Goods" means only the following: (i) product shipped is different than identified in Buyer's purchase order; or (ii) product's label or packaging incorrectly identifies its contents.
- (b) If Buyer timely notifies Seller of any Nonconforming Goods, Seller shall, in its sole discretion (i) replace such Nonconforming Goods with conforming Deliverables, or (ii) credit or refund the Price for such Nonconforming Goods, together with any reasonable shipping and handling expenses incurred by Buyer in connection therewith. Buyer shall ship, at Seller's expense and risk of loss, the Nonconforming Goods to the Delivery Point. If Seller exercises its option to replace Nonconforming Goods, Seller shall, after receiving Buyer's shipment of Nonconforming Goods, ship to Buyer, at Seller's expense and risk of loss, the replaced Deliverables to the Delivery Point.
- (c) Buyer acknowledges and agrees that the remedies set forth in Section 11(b) are Buyer's exclusive remedies for the delivery of Nonconforming Goods. Except as provided under Section 11(a), all sales of Deliverables to Buyer are made on a one-way basis and Buyer has no right to return Deliverables purchased to Seller.

12. **TERMINATION FOR CONVENIENCE:** If Buyer cancels its order after acceptance by Seller, Buyer shall pay Seller the actual and substantiated costs of Seller, which may include a reasonable profit, for the work performed in accordance with the Contract up to the effective date of termination plus any reasonable and substantiated expenses incurred directly related to the termination.

13. **LIMITED WARRANTY:**

- (a) Seller warrants to Buyer that for a period of 12 months from the date of shipment of the Deliverables (the "Warranty Period"), that such Deliverables will materially conform to Seller's published specifications in effect as of the date of shipment and will be free from material defects in material and workmanship.
- (b) EXCEPT FOR THE WARRANTY SET FORTH IN SECTION 13(a), SELLER MAKES NO WARRANTY WHATSOEVER WITH RESPECT TO THE DELIVERABLES, INCLUDING ANY WARRANTY OF MERCHANTABILITY OR FITNESS FOR A PARTICULAR PURPOSE; WHETHER EXPRESS



OR IMPLIED BY LAW, COURSE OF DEALING, COURSE OF PERFORMANCE, USAGE OF TRADE OR OTHERWISE.

- (c) Products manufactured by a third party (a "Third Party Product") may constitute, contain, be contained in, incorporated into, attached to, or packaged together with the Deliverables. Third Party Products are not covered by the warranty in Section 13(a). Seller will, however, pass through all existing warranties for such Third Party Products at the time of delivery. Buyer will then be responsible for managing the warranties for Third Party Products. For the avoidance of doubt, SELLER MAKES NO REPRESENTATIONS OR WARRANTIES WITH RESPECT TO ANY THIRD PARTY PRODUCT, INCLUDING ANY (i) WARRANTY OF MERCHANTABILITY; (ii) WARRANTY OF FITNESS FOR A PARTICULAR PURPOSE; (iii) WARRANTY OF TITLE; OR (iv) WARRANTY AGAINST INFRINGEMENT OF INTELLECTUAL PROPERTY RIGHTS OF A THIRD PARTY; WHETHER EXPRESS OR IMPLIED BY LAW, COURSE OF DEALING, COURSE OF PERFORMANCE, USAGE OF TRADE, OR OTHERWISE.
- (d) Seller shall not be liable for a breach of the warranty set forth in Section 13(a) unless: (i) Buyer gives written notice of the defect, reasonably described, to Seller within fifteen (15) days of the time when Buyer discovers or ought to have discovered the defect; (ii) Seller is given a reasonable opportunity after receiving the notice to examine such Deliverables and Buyer (if requested to do so by Seller) returns such Deliverables to Seller's place of business at Seller's cost for the examination to take place there; and (iii) Seller reasonably verifies Buyer's claim that the Deliverables are defective.
- (e) The Seller shall not be liable for a breach of the warranty set forth in Section 13(a) if: (i) Buyer makes any further use of such Deliverables after giving such notice; (ii) the defect arises because Buyer failed to follow Seller's oral or written instructions as to the storage, installation, commissioning, use or maintenance of the Deliverables; or (iii) Buyer alters or repairs such Deliverables without the prior written consent of Seller.
- (f) Subject to Section 13(d) and Section 13(e) above, with respect to any such Deliverables during the Warranty Period, Seller shall, in its sole discretion, either: (i) repair or replace such Deliverables (or the defective part) or (ii) credit or refund the price of such Deliverables at the pro rata contract rate provided that, if Seller so requests, Buyer shall, at Seller's expense, return such Deliverables to Seller. Replacement Deliverables or repairs provided by Seller are warranted for the remaining Warranty Period. There shall be no extended warranty period, expressed or

implied, unless agreed in writing by Seller and the warranty shall not extend to any costs incurred by the Buyer for removal and/or replacement of the defective product or component part.

- (g) THE REMEDIES SET FORTH IN SECTION 13(f) SHALL BE BUYER'S SOLE AND EXCLUSIVE REMEDY AND SELLER'S ENTIRE LIABILITY FOR ANY BREACH OF THE LIMITED WARRANTY SET FORTH IN SECTION 13(a).

#### 14. LIMITATION OF LIABILITY:

- (a) IN NO EVENT SHALL SELLER BE LIABLE FOR ANY CONSEQUENTIAL, INDIRECT, INCIDENTAL, SPECIAL, EXEMPLARY, OR PUNITIVE DAMAGES, LOST PROFITS OR REVENUES OR DIMINUTION IN VALUE, ARISING OUT OF OR RELATING TO ANY BREACH OF THE AGREEMENT, WHETHER OR NOT THE POSSIBILITY OF SUCH DAMAGES HAS BEEN DISCLOSED IN ADVANCE BY BUYER, OR COULD HAVE BEEN REASONABLY FORESEEN BY BUYER, REGARDLESS OF THE LEGAL OR EQUITABLE THEORY (CONTRACT, TORT OR OTHERWISE) UPON WHICH THE CLAIM IS BASED, AND NOTWITHSTANDING THE FAILURE OF ANY AGREED OR OTHER REMEDY OF ITS ESSENTIAL PURPOSE.
- (b) IN NO EVENT SHALL SELLER'S AGGREGATE LIABILITY ARISING OUT OF OR RELATED TO THIS AGREEMENT, WHETHER ARISING OUT OF OR RELATED TO BREACH OF CONTRACT, TORT (INCLUDING NEGLIGENCE) OR OTHERWISE, EXCEED TWO TIMES THE AMOUNT ACTUALLY PAID TO SELLER FOR THE DELIVERABLES SOLD HEREUNDER; PROVIDED, HOWEVER, THAT THE FOREGOING LIMITATION SHALL NOT APPLY IN INSTANCES ARISING OUT OF OR RELATED TO GROSS NEGLIGENCE OR WILLFUL MISCONDUCT.

15. INDEMNIFICATION: Seller shall indemnify, defend and save harmless the Buyer, its officers, agents and employees from any and all claims, demands, damages, costs, expenses (including reasonable attorney's fees), judgments or liabilities (collectively, "Losses") to the extent arising out of the negligent performance of the provisions hereof; including any willful or negligent act or omission to act on the part of the Seller or his agents or employees or other independent contractors directly responsible to him to the fullest extent allowable by law.

16. INSURANCE: Seller shall procure and maintain for the duration of this Agreement insurance against claims for injuries to persons or damages to property which may arise from or in connection with the performance of the work hereunder and the results of that work by the Seller, its agents, representatives, employees or subcontractors.

Coverage shall be at least as broad as:

- (a) Commercial General Liability (CGL): Insurance Services Office (ISO) Form CG 00 01 covering CGL on an “occurrence” basis, including products-completed operations, personal & advertising injury, with limits no less than \$1,000,000 per occurrence and \$2,000,000 in the aggregate.
- (b) Aircraft Liability: Insurance for bodily injury and property damage liability with a combined single limit no less than \$10,000,000.
- (c) Hangerkeepers Liability: with a limit not less than \$5,000,000 combined single limit per occurrence and \$5,000,000 aggregate.
- (d) Aviation Products and Completed Operations Liability Insurance, with limit of no less than \$1,000,000 per occurrence or claim, \$2,000,000 aggregate.
- (e) Workers’ Compensation: as required by the State of California, with Statutory Limits, and Employer’s Liability Insurance with limit of no less than \$1,000,000 per accident for bodily injury or disease.

Buyer shall maintain the following insurance policies during the term of this Agreement: (1) Workers’ Compensation insurance in compliance with all State laws to include statutory limits and Employers’ Liability with minimum limits of \$500,000 and containing a waiver of subrogation in favor of the other Party; and (2) General Liability insurance with minimum limits of \$5 million per occurrence and \$5 million annual aggregate.

17. Other Insurance Provisions

The insurance policies are to contain, or be endorsed to contain, the following provisions:

- (a) Additional Insured – Buyer, its officers, officials, employees, agents and volunteers are to be covered as additional insureds on the CGL, Hangarkeepers and Aviation Products and Completed Operations Liability policies with respect to liability arising out of work or operations performed by or on behalf of the Seller including materials, parts, or equipment furnished in connection with such work or operations. The General liability coverage can be provided in the form of a certificate of insurance and endorsement naming the Buyer, its officers, agents and employees as an additional insured.
- (b) Primary Coverage – For any claims related to this Agreement, the Buyer’s insurance coverage shall be primary insurance as respects the Buyer, its officers, officials, employees, agents and volunteers. Any insurance or self-insurance maintained by the Buyer, its officers, officials, employees, agents or volunteers

shall be excess of the Seller’s insurance and shall not contribute with it.

- (c) Notice of Cancellation – Seller shall provide that coverage shall not be canceled, except with notice to the Buyer.
- (d) Waiver of Subrogation Rights – Seller hereby grants to Buyer a waiver of any right to subrogation which any insurer of said Seller may acquire against the Buyer by virtue of the payment of any loss under such insurance.
- (e) Acceptability of Insurers – Unless otherwise approved by Risk Management, insurance shall be written by insurers authorized to do business in the State of California and with a minimum A.M. Best’s Insurance Guide rating of “A- VII”.
- (f) Verification of Coverage – Seller shall furnish the Buyer with proof of insurance, certificates and amendatory endorsements as required by this Agreement. The proof of insurance, certificates and endorsements are to be received and approved by the Buyer before work commences. However, failure to obtain the required documents prior to the work beginning shall not waive the Seller’s obligation to provide them. The Seller shall furnish evidence of renewal of coverage throughout the term of the Agreement.
- (g) Failure to Procure Coverage – In the event that any policy of insurance required under this Agreement does not comply with the requirements, is not procured, or is canceled and not replaced, Buyer has the right but not the obligation or duty to terminate the Agreement. Maintenance of required insurance coverage is a material element of the Agreement and failure to maintain or renew such coverage or to provide evidence of renewal may be treated by Buyer as a material breach of contract.
- (h) Subcontractors – Seller shall require and verify that all subcontractors maintain insurance meeting all the requirements stated herein, and Seller shall ensure that Buyer is an additional insured on insurance required from subcontractors.

18. NOTIFICATION OF INCIDENTS: Each Party agrees to promptly notify the other Party after the discovery of any incidents, occurrences, claims, or other causes of action involving this Agreement. The Parties agree to cooperate with each other as may be necessary to resolve such matters.

19. COMPLIANCE: During the term of the Agreement, the Parties agree to comply with any and all laws, rules, regulations, licensing requirements or standards that are now or hereafter promulgated by any local, state, and federal governmental authority/agency or accrediting/administrative body that governs or

applies to their respective duties and obligations hereunder (the “Applicable Laws and Standards”).

20. **FORCE MAJEURE:** Seller shall not be liable for, nor deemed to be in default by reason of any failure to deliver or any delay in delivery of Deliverables due to any cause beyond its reasonable control. Such causes shall include, but not be limited to delays resulting from acts of God or the public enemy, acts of a government authority, war or terrorism, accident, fire, flood, epidemic, pandemic, weather, labor difficulties, interruptions to or unavailability of transportation, inability to obtain supplies, or for any cause interfering with the use its production facilities or those of its sources of supply.

21. **PROPRIETARY DATA:** Except as otherwise provided below, Buyer agrees to protect any confidential information, technical data, or drawings delivered to or accessed by Buyer in relation to the Deliverables if such confidential information, technical data, or drawings bear Seller’s proprietary or restrictive legend (“Confidential Information”). Seller shall remain the owner of all such Confidential Information and under no circumstances shall Buyer assert any ownership or use rights in or relating to any such Confidential Information provided by Seller pursuant hereto, except pursuant to a written agreement with Seller. Buyer shall not disclose Seller’s Confidential Information to any third party without Seller’s express written consent; provided, however, that Buyer may disclose such information if required under the Public Records Act (Cal. Gov. Code section 6250, et seq.), provided further that Buyer requests an extension to respond to the Public Records Act request if authorized under Cal. Gov. Code section 6253(c) and provides prompt written notice of such request to Seller so that Seller may seek a protective order or other appropriate remedy. In addition, Buyer may disclose Confidential Information to any of Buyer’s agents, consultants or representatives who need to know such information for purposes of maintaining or repairing the Deliverables, provided that Buyer informs such third party of the confidential and proprietary nature of the information and the restrictions on use and disclosure set forth herein, and further that Buyer will be responsible for any breach of this provision by such third party. Buyer will protect Seller’s Confidential Information using the same degree of care it uses to restrict disclosure and use of its own confidential information, but no less than a reasonable standard of care. Upon Seller’s request or completion of this Order, Buyer shall promptly return or destroy all Confidential Information to Seller, except for any materials necessary to operate, maintain or repair the Deliverables.

22. **AMENDMENT; WAIVER:** These Terms may only be amended or modified in a writing which specifically states that it amends these Terms and is signed by the parties to this agreement. No waiver by Seller of any of the provisions of this Agreement is effective unless explicitly set forth in writing and signed by Seller. No failure to exercise, or delay in exercising, any rights, remedy, power or privilege arising from this Agreement operates or may be construed as a waiver thereof. No single or partial exercise of any right, remedy, power or privilege hereunder precludes any other or further exercise thereof or the exercise of any other right, remedy, power or privilege.

23. **ASSIGNMENT:** Buyer shall not assign any of its rights or delegate any of its obligations under this Agreement without the prior written consent of Seller. Any purported assignment or delegation in violation of this Section 21 is null and void. Unless written consent is first provided by Seller, no Buyer assignment or delegation relieves Buyer of any of its obligations under this Agreement.

24. **RELATIONSHIP OF PARTIES:** The relationship between the Parties is that of independent contractors. Nothing contained in this Agreement shall be construed as creating any agency, partnership, joint venture or other form of joint enterprise, employment or fiduciary relationship between the Parties, and neither Party shall have authority to contract for or bind the other Party in any manner whatsoever.

25. **NO THIRD-PARTY BENEFICIARIES:** This Agreement is for the sole benefit of the Parties and their respective successors and permitted assigns and nothing herein, express or implied, is intended to or shall confer upon any other person or entity any legal or equitable right, benefit or remedy of any nature whatsoever under or by reason of these Terms; *provided, however*, that in the event Buyer resells the Deliverables to another party, such party shall be an intended third party beneficiary of these Terms.

26. **GOVERNING LAW:** All matters arising out of or relating to this Agreement is governed by and construed in accordance with the internal laws of the State of California, United States of America, without giving effect to any choice or conflict of law provisions thereof.

27. **SUBMISSION TO JURISDICTION:** Any legal suit, action or proceeding arising out of or relating to this Agreement shall be instituted in the state or federal courts of the United States of America, in the State of California, located in the County of Santa Barbara, and each Party irrevocably submits to the exclusive jurisdiction of such courts in any such suit, action or proceeding.

28. **SEVERABILITY:** If any term or provision of this Agreement is invalid, illegal or unenforceable in any jurisdiction, such invalidity, illegality or unenforceability shall not affect any other term or provision of this Agreement or invalidate or render unenforceable such term or provision in any other jurisdiction.

29. **SURVIVAL:** Provisions of these Terms which by their nature should apply beyond their terms will remain in force after any termination or expiration of this Order including, but not limited to, Section 13 through this Section 28.

**UNITED ROTORCRAFT, a division of Air Methods Corporation**

By:  \_\_\_\_\_

Name: Larry Alexandre

Title: President

Date: 11/02/2020



1-18

SANTA BARBARA COUNTY FIRE DEPARTMENT

By: *Gregg Hart*

Name: Gregg Hart

Title: Chair, Board of Supervisors

Date: 11-17-2020

EXHIBIT B

PAYMENT ARRANGEMENTS

Periodic Compensation at Selected Milestones

- A. For CONTRACTOR services to be rendered under this Agreement, CONTRACTOR shall be paid a total contract amount, including cost reimbursements, not to exceed \$ **2,495,000**.
- B. Payment for services and /or reimbursement of costs shall be made upon CONTRACTOR's satisfactory performance, based upon the scope and methodology contained in **EXHIBIT A** as determined by COUNTY.
- A. Upon completion of the work for each milestone and/or delivery to COUNTY of item(s) specified below, CONTRACTOR shall submit to the COUNTY DESIGNATED REPRESENTATIVE an invoice or certified claim on the County Treasury for the service performed in accomplishing each milestone. These invoices or certified claims must cite the assigned Board Contract Number. COUNTY DESIGNATED REPRESENTATIVE shall evaluate the quality of the service performed and/or item(s) delivered and if found to be satisfactory shall initiate payment processing. COUNTY shall pay invoices or claims for satisfactory work within 30 days of receipt of correct and complete invoices or claims from CONTRACTOR.

**United Rotorcraft Fixed-Belly Tank Firm Fixed Pricing Schedule**

<b>Milestone</b>	<b>Time frame</b>	<b>Description</b>	<b>Details</b>	<b>Total Amount</b>	<b>Percent</b>
Milestone 1	Contract Award	Uninstalled Finished Goods	For Acquisition of Materials: Belly Tank, Snorkel, Kit Hard Points, Electrical/Controls	\$ 998,000	40%
Milestone 2	April-21	Aircraft Induction in Englewood, CO	Functional Costs: Engineering, Landing Gear Modification, Tank Controls and Displays, Tank/Kit Installation	\$ 748,500	30%
Milestone 3	July-21	Customer Acceptance	After Final Inspection is Performed and Accepted by COUNTY	\$ 748,500	30%
<b>Total Cost for Fixed-Belly Modification</b>				<b>\$ 2,495,000</b>	<b>100%</b>

The final milestone payment above shall not be made until all services have been completed and item(s) as specified in **EXHIBIT A** have been delivered and found to be satisfactory.

- D. COUNTY's failure to discover or object to any unsatisfactory work or billings prior to payment will not constitute a waiver of COUNTY's right to require CONTRACTOR to correct such work or billings or seek any other legal remedy.

Board Contract Summary

For use with Expenditure Contracts submitted to the Board for approval. Complete information below, print, obtain signature of authorized departmental representative, and submit this form, along with attachments, to the appropriate departments for signature. See also: Auditor-Controller Intranet Policies->Contracts.

Table with 4 rows: D1. Fiscal Year (2020-21), D2. Department Name (Fire), D3. Contact Person (Diane Sauer), D4. Telephone (805-681-5505)

Table with 13 rows: K1. Contract Type (Capital checked), K2. Brief Summary of Contract Description/Purpose (Items, materials, and services necessary for the installation of a fixed belly tank for...), K3. Department Project Number (NA), K4. Original Contract Amount (\$ 2,485,000), K5. Contract Begin Date (11/17/2020), K6. Original Contract End Date (6/30/2022), K7. Amendment? (No), K8. - New Contract End Date (NA), K9. - Total Number of Amendments (NA), K10. - This Amendment Amount (\$ NA), K11. - Total Previous Amendment Amounts (\$ NA), K12. - Revised Total Contract Amount (\$ 2,485,000)

Table with 6 rows: B1. Intended Board Agenda Date (11/17/2020), B2. Number of Workers Displaced (if any) (0), B3. Number of Competitive Bids (if any) (0), B4. Lowest Bid Amount (if bid) (NA), B5. If Board waived bids, show Agenda Date (11/17/2020) and Agenda Item Number, B6. Boilerplate Contract Text Changed? (If Yes, cite Paragraph) (No)

Table with 7 rows: F1. Fund Number (2280), F2. Department Number (031), F3. Line Item Account Number (8300), F4. Project Number (if applicable) (NA), F5. Program Number (if applicable) (6030), F6. Org Unit Number (if applicable) (3000), F7. Payment Terms (Net 30)

Table with 10 rows: V1. Auditor-Controller Vendor Number (NA), V2. Payee/Contractor Name (United Rotorcraft), V3. Mailing Address (7301 S. Peoria Street), V4. City State (two-letter) Zip (include +4 if known) (Englewood, Colorado 80112), V5. Telephone Number (303-792-7400), V6. Vendor Contact Person (Cynthia McCully, Project Manager), V7. Workers Comp Insurance Expiration Date, V8. Liability Insurance Expiration Date, V9. Professional License Number, V10. Verified by (print name of county staff)

V11 Company Type (Check one): Individual Sole Proprietorship Partnership Corporation (checked)

I certify information is complete and accurate; designated funds available; required concurrences evidenced on signature page.

Date: 11/5/2020 Authorized Signature: [Handwritten Signature]